

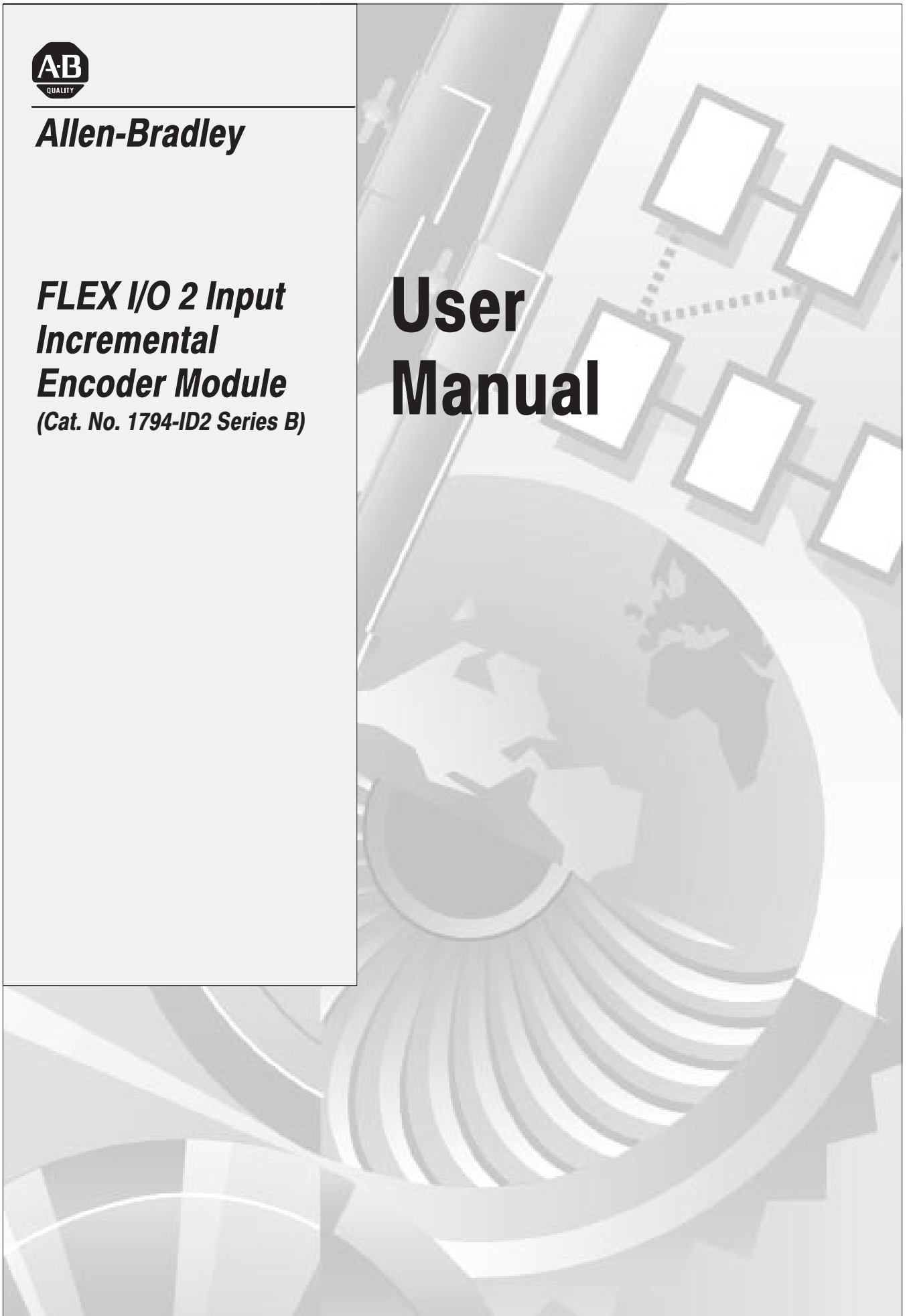

Allen-Bradley

***FLEX I/O 2 Input
Incremental
Encoder Module
(Cat. No. 1794-ID2 Series B)***

User Manual



Important User Information

Because of the variety of uses for the products described in this publication, those responsible for the application and use of this control equipment must satisfy themselves that all necessary steps have been taken to assure that each application and use meets all performance and safety requirements, including any applicable laws, regulations, codes and standards.

The illustrations, charts, sample programs and layout examples shown in this guide are intended solely for example. Since there are many variables and requirements associated with any particular installation, Allen-Bradley does not assume responsibility or liability (to include intellectual property liability) for actual use based upon the examples shown in this publication.

Allen-Bradley publication SGI-1.1, “Safety Guidelines For The Application, Installation and Maintenance of Solid State Control” (available from your local Allen-Bradley office) describes some important differences between solid-state equipment and electromechanical devices which should be taken into consideration when applying products such as those described in this publication.

Reproduction of the contents of this copyrighted publication, in whole or in part, without written permission of Allen-Bradley Company, Inc. is prohibited.

Throughout this manual we make notes to alert you to possible injury to people or damage to equipment under specific circumstances.



ATTENTION: Identifies information about practices or circumstances that can lead to personal injury or death, property damage, or economic loss.

Attention helps you:

- identify a hazard
- avoid the hazard
- recognize the consequences

Important: Identifies information that is especially important for successful application and understanding of the product.

Important: We recommend you frequently backup your application programs on appropriate storage medium to avoid possible data loss.

DeviceNet, DeviceNetManager, and RediSTATION are trademarks of Allen-Bradley Company, Inc.

PLC, PLC-2, PLC-3, and PLC-5 are registered trademarks of Allen-Bradley Company, Inc.

Windows is a trademark of Microsoft.

Microsoft is a registered trademark of Microsoft

IBM is a registered trademark of International Business Machines, Incorporated.

All other brand and product names are trademarks or registered trademarks of their respective companies.

Summary of Changes

The information contained in this manual pertains to the series B version of the 1794-ID2 frequency input module.

New Information

This version of this publication contains information on control word 2, for setting the filter function for the counters. This filter information is contained in chapter 1 and identified in chapters 4 and 5.

Updated Information

The vibration specifications for this module have been updated. The specification is as follows:

Environmental Conditions	
Operational Temperature	0 to 55°C (32 to 131°F) Note: Do not connect maximum input voltage simultaneously to all inputs if the module ambient temperature is expected to exceed 40°C.
Storage Temperature	-40 to 85°C (-40 to 185°F)
Relative Humidity	5 to 90% noncondensing (operating) 5 to 80% noncondensing (nonoperating)
Shock	Operating 30g peak acceleration, 11(+1)ms pulse width
	Nonoperating 50g peak acceleration, 11(+1)ms pulse width
Vibration	Tested 50g @ 10-500Hz per IEC 68-2-6

Using This Manual

Purpose of this Manual

This manual shows you how to use your FLEX I/O pulse counter module with Allen-Bradley programmable controllers. The manual helps you install, program and troubleshoot your module.

Audience

You must be able to program and operate an Allen-Bradley programmable controller to make efficient use of your FLEX I/O module. In particular, you must know how to program block transfers.

We assume that you know how to do this in this manual. If you do not, refer to the appropriate programming and operations manual before you attempt to program your modules.

Vocabulary

In this manual, we refer to:

- the pulse counter module as the “input module”
- the Programmable Controller as the “controller”

Manual Organization



This manual is divided into seven chapters. The following chart lists each chapter with its corresponding title and a brief overview of the topics covered in that chapter.

Chapter	Title	Contents
1	Overview of FLEX I/O and the Pulse Counter Module	Describes FLEX I/O pulse counter modules, features, and how they function
2	How to Install Your Pulse Counter Module	How to install and wire the module
3	Module Programming	Explains block transfer programming, sample programs
4	Writing Configuration to and Reading Status From with a Remote I/O Adapter	Explains how to configure your modules and read status information from your modules when using a remote I/O adapter
5	How Communication Takes Place and I/O Image Table Mapping with the DeviceNet Adapter	Explains how you communicate with your modules, and how the I/O image is mapped when using a DeviceNet adapter
6	Input, Output and Configuration files for Analog Modules using ControlNet	Explains how you communicate with your modules, and how the I/O and configuration files are mapped when using a ControlNet adapter
7	Calibrating Your Pulse Counter Module	How to calibrate the module.
8	Troubleshoot Your Pulse Counter Module	How to use the indicators to troubleshoot your module.

Appendix	Title	Contents
A	Specifications	Specifications for the pulse counter module

Conventions

We use these conventions in this manual:

In this manual, we show:	Like this:
that there is more information about a topic in another chapter in this manual	
that there is more information about the topic in another manual	

For Additional Information

For additional information on FLEX I/O systems and modules, refer to the following documents:

Catalog Number	Voltage	Description	Publications	
			Installation Instructions	User Manual
1794		1794 FLEX I/O Product Data	1794-2.1	
1794-ACN	24V dc	ControlNet Adapter	1794-5.8	
1794-ACNR	24V dc	Redundant Media ControlNet Adapter	1794-5.18	
1794-ACN15	24V dc	ControlNet Adapter	1794-5.47	
1794-ACNR15	24V dc	Redundant Media ControlNet Adapter	1794-5.48	
1794-ADN	24V dc	DeviceNet Adapter	1794-5.14	1794-6.5.5
1794-ASB/C	24V dc	Remote I/O Adapter	1794-5.50	1794-6.5.9
1794-ASB2/B	24V dc	2-Slot Remote I/O Adapter	1794-5.44	1794-6.5.13
1794-APB	24V dc	Profibus Adapter	1794-5.40	1794-6.5.6
1794-IB8	24V dc	8 Sink Input Module	1794-5.30	
1794-OB8	24V dc	8 Source Output Module	1794-5.31	
1794-IB16	24V dc	16 Sink Input Module	1794-5.4	
1794-OB16	24V dc	16 Source Output Module	1794-5.3	
1794-IV16	24V dc	16 Source Input Module	1794-5.28	
1794-OV16	24V dc	16 Sink Output Module	1794-5.29	
1794-OB8EP	24V dc	8 Electronically Fused Output Module	1794-5.20	
1794-IB8S	24V dc	Sensor Input Module	1794-5.7	
1794-IB10XOB6	24V dc	10 Input/6 Output Module	1794-5.24	
1794-IE8	24V dc	Selectable Analog 8 Input Module	1794-5.6	1794-6.5.2
1794-OE4	24V dc	Selectable Analog 4 Output Module	1794-5.5	

Table continued on next page

Catalog Number	Voltage	Description	Publications		
			Installation Instructions	User Manual	
1794-IE4XOE2	24V dc	4 Input/2 Output Analog Module	1794-5.15	1794-6.5.2	
1794-OF4	24V dc	4 Output Isolated Analog Module	1794-5.37	1794-6.5.8	
1794-IF4	24V dc	4 Input Isolated Analog Module	1794-5.38		
1794-IF2XOF2	24V dc	2 Input/2 Output Isolated Analog Module	1794-5.39		
1794-IR8	24V dc	8 RTD Input Analog Module	1794-5.22	1794-6.5.4	
1794-IT8	24V dc	8 Thermocouple Input Module	1794-5.21	1794-6.5.7	
1794-IRT8	24V dc	8 Thermocouple/RTD Input Module	1794-5.50	1794-6.5.12	
1794-IJ2	24V dc	2 Frequency Input Module	1794-5.49	1794-6.5.11	
1794-IA8	120V ac	8 Input Module	1794-5.9		
1794-OA8	120V ac	Output Module	1794-5.10		
1794-TB2 1794-TB3		2-wire Terminal Base 3-wire Terminal Base	1794-5.2		
1794-TBN		Terminal Base Unit	1794-5.16		
1794-TBNF		Fused Terminal Base Unit	1794-5.17		
1794-TB3T		Temperature Terminal Base Unit	1794-5.41		
1794-TB3S		Spring Clamp Terminal Base Unit	1794-5.42		
1794-TB3TS		Spring Clamp Temperature Base Unit	1794-5.43		
1794-TB3G		Terminal Base Unit	1794-5.51		
1794-TB3GS		Spring Clamp Terminal Base Unit	1794-5.59		
1794-CE1, -CE3		Extender Cables	1794-5.12		
1794-NM1		Mounting Kit	1794-2.13		
1794-PS1		24V dc	Power Supply		1794-5.35

Summary

This preface gave you information on how to use this manual efficiently. The next chapter introduces you to the frequency module.

Overview of the Incremental Encoder Module

Chapter 1

What This Chapter Contains	1-1
How You Use the Incremental Encoder Module	1-1
What the Incremental Encoder Module Does	1-2
Typical Applications	1-3
Input Capabilities	1-3
How the Incremental Encoder Operates	1-4
Variables	1-4
Start Counting	1-4
Selecting the incremental encoder and up/down counting	1-4
Up/Down Counting Controlled by B Input	1-5
Up/Down Counting using Pulses at Inputs A and B	1-5
Count Pulses from Incremental Encoders	1-6
Preset Function	1-7
.....	1-7
Gate Function	1-7
Store Function	1-8
Limitation Function	1-8
Chapter Summary	1-9

How to Install Your Incremental Encoder Module

Chapter 2

What This Chapter Contains	2-1
Before You Install Your Input Module	2-1
European Union Directive Compliance	2-1
EMC Directive	2-1
Low Voltage Directive	2-2
Power Requirements	2-2
Wiring the Terminal Base Units (1794-TB3G shown)	2-3
Installing the Module	2-4
Mounting the Terminal Base Unit on a DIN Rail	2-4
Panel/Wall Mounting	2-6
Mounting the Incremental Encoder Module on the Terminal Base Unit	2-7
Connecting Wiring for Your incremental encoder Module	2-9
Wiring to a 1794-TBN or -TBNF Terminal Base Unit	2-11
Wiring connections for the 1794-ID2 incremental encoder Module	2-12
Example of Pulse Transmitter Wiring	2-13
Example of Incremental Encoder Wiring	2-13
Module Indicators	2-14
Chapter Summary	2-14

Programming Your Incremental Encoder Module

Chapter 3

What This Chapter Contains	3-1
Enter Block Transfer Instructions	3-1
PLC-2 Family Processor	3-2
PLC-5 Family Processor	3-2
SLC-5 Programming	3-3
Chapter Summary	3-8

Writing Configuration to and Reading Status from Your Module with a Remote I/O Adapter

Chapter 4

What This Chapter Contains	4-1
Configuring Your Incremental Encoder Module	4-1
Reading Data From Your Module	4-2
Mapping Data for the Module	4-2
Incremental Encoder Module (1794-ID2) Image Table Mapping ..	4-2
Block Transfer Read Word Assignments for the Incremental Encoder Module (1794-ID2)	4-3
Bit/Word Definitions for Block Transfer Read Words for the Incremental Encoder Module	4-3
Block Transfer Write Word Assignments for the Incremental Encoder Module	4-5
Bit/Word Definitions for the Block Transfer Write Words for the Incremental Encoder Module	4-5
Chapter Summary	4-7

How Communication Takes Place and I/O Image Table Mapping with the DeviceNet Adapter

Chapter 5

What This Chapter Contains	5-1
About DeviceNetManager Software	5-1
Polled I/O Structure	5-1
Adapter Input Status Word	5-2
System Throughput	5-3
Mapping Data into the Image Table	5-3
Incremental Encoder Module (1794-ID2) Image Table Mapping ..	5-3
Block Transfer Read Word Assignments for the Incremental Encoder Module (1794-ID2)	5-4
Block Transfer Write Word Assignments for the Incremental Encoder Module (1794-ID2)	5-4
Bit/Word Definitions for the incremental encoder Module (1794-ID2)	5-5
Defaults	5-8

Input, Output and Configuration Files for Analog Modules when used with ControlNet	Chapter 6	
	Chapter Objectives	6-1
	About the ControlNet Adapter	6-1
	Scheduled Data-Transfer	6-2
	Unscheduled Data-Transfer	6-2
	Module I/O Mapping	6-2
	I/O Structure	6-3
	Adapter Input Status Word	6-3
	Safe State Data	6-4
	Device Actions	6-4
	Communication Fault Behavior	6-5
	Idle State Behavior	6-5
	Input Data Behavior upon Module Removal	6-5
	Incremental Encoder Module (1794-ID2) Image Table Mapping	6-6
	Bit/Word Definitions for Block Transfer Read Words for the Pulse Counter Module	6-6
Calibrating Your Incremental Encoder Module	Chapter 7	
	Chapter Objective	7-1
	Calibrating Your Module	7-1
	Calibration Method 1	7-2
	Calibration Method 2	7-3
Troubleshoot the Incremental Encoder Module	Chapter 8	
	What This Chapter Contains	8-1
	Status Indicators	8-1
	What's Next	8-2
Specifications	Appendix A	
	Specifications	A-1

Overview of the Incremental Encoder Module

What This Chapter Contains

Read this chapter to familiarize yourself with the 1794-ID2 module.

For information on	See page
How You Use the incremental encoder Module	1-1
What the incremental encoder Module Does	1-2
Input Capabilities	1-3
How the incremental encoder Operates	1-4

How You Use the incremental encoder Module

The 1794-ID2 module is an intelligent I/O module designed to perform high speed pulse counting. The module provides:

- 2 pulse transmitter interfaces, each with 4 optocoupled inputs
- Each input has + and – inputs for connection to transmitters with complementary and noncomplementary signals.

The pulse inputs can accept frequencies up to 100KHz. The module accepts and returns binary data.

The module's primary use is accurate, high-speed counting of pulse from pulse transmitters or incremental encoders with 1 or 2 pulse trains. This includes quantity counting, positioning and speed calculations.

The module has 2 up/down counters, each individually programmable. The number of edges to be counted can be multiplied by 1, 2 or 4 (x1, x2, x4). Pulse transmitters can be complementary or noncomplementary.

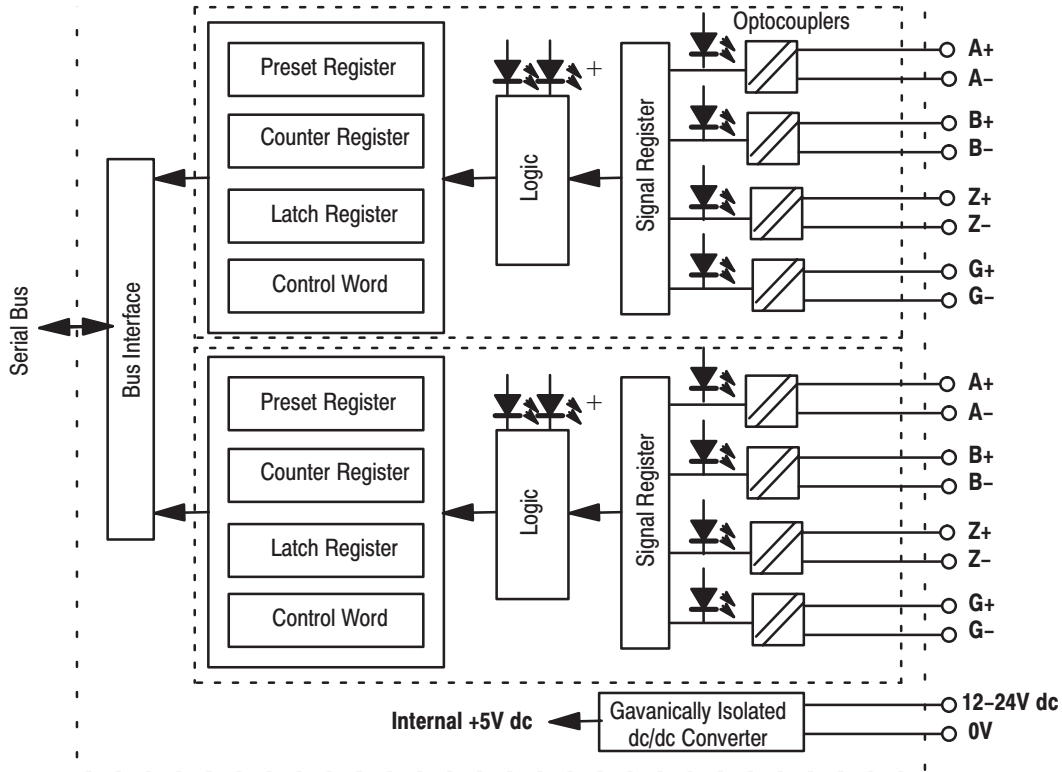

What the Incremental Encoder Module Does

The incremental encoder module performs high-speed scaling calculation operations for various industrial applications. The module interfaces with a FLEX family adapter which then communicates with a programmable controller processor that has block-transfer capability and external I/O devices.

The adapter/power supply transfers data to the module (block transfer write) and from the module (block transfer read) using BTW and BTR instructions in your ladder diagram program. These instructions let the adapter read input values and status from the module, and let you write output values and configure the module's mode of operation. The following illustration describes the communication process.

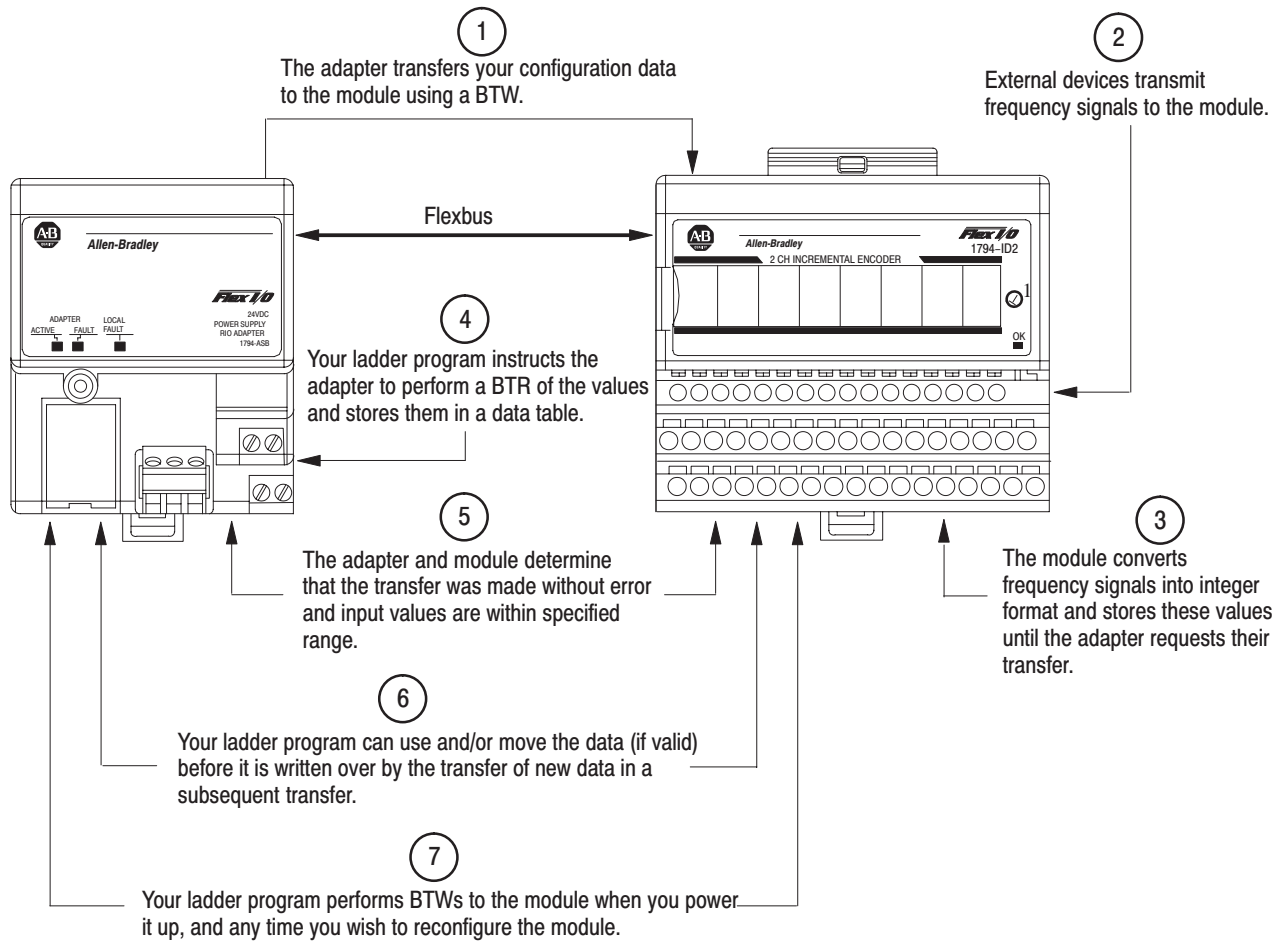

Typical Applications

You can use the 1794-ID2 module in the power management, automotive, food and beverage, and oil and gas industries for various flow and/or turbine metering applications. Some sample applications include:

- turbine shaft speed monitoring
- automotive paint booths
- brewery flow monitoring
- petrochemical flow and custody transfer

Input Capabilities

The incremental encoder module has 2 identical input channels. Each of the input channels may accept these input signals:

- A+ and A-
- B+ and B-
- Z+ and Z-
- G+ and G-

The pulse inputs can accept frequencies up to 100KHz. The module accepts and returns binary data.

How the incremental encoder Operates

The counter module handles up/down counting and detection of selectable number of edges (X1, X2, X4) for incremental encoders with 2 pulse trains, nominal 90° out of phase. The minimum stable input condition is 2μs. The following paragraphs detail operation of the incremental encoder module.

Each of the 2 counters has a 16-bit counter register, a preset register and a latch register.

Variables

Communication between the counter module and the control system uses variables accessible in the control system program. These variables include:

- a counter register (*Counter*)
- a preset register (*PresetValue*)
- a latch register (*LatchValue*).

Signal registers and control words are used to set parameters for the counter configuration. The control word sent to the incremental encoder module can be read back to the control system, allowing verification that one I/O scan been performed since the cycle has been initiated.

Start Counting

The control bit CounterEnable enables counting. It must be set to 1 to enable counting and all other functions.

Selecting the incremental encoder and up/down counting

Depending on the incremental encoder, the module can be set in different counter modes. The parameter is set using a 3 digit code in write word 1 or 2 (depending on the channel) control word.

Mode Selection				
Bit	02	01	00	Mode Selection bits
	0	0	0	Counting on positive (rising) edge of input signal A. (Up/dwn counting determined by B.)
	0	0	1	Quadrature encoder X1
	0	1	0	Quadrature encoder X2
	0	1	1	Quadrature encoder X4
	1	0	0	Counting up on the positive edge of input signal A, and down on positive edge of input signal B.
	1	0	1	No count function.
	1	1	0	No count function.
	1	1	1	No count function.

Up/Down Counting Controlled by B Input

Pulse Counting (Mode 000)

Up/Down counting controlled by input B

The positive edge of the pulses are counted at input A. If input B = 0, the counter counts up; if B = 1, the counter counts down.

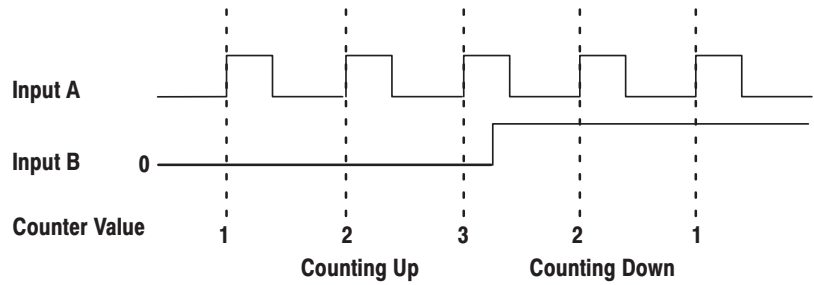
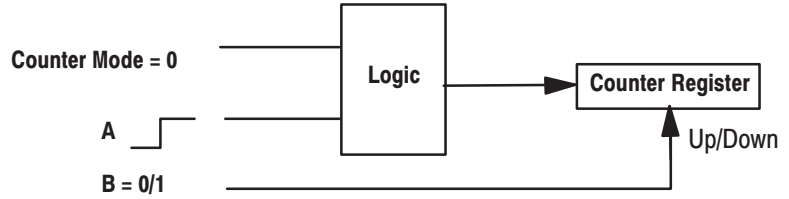

Up/Down Counting using Pulses at Inputs A and B

Pulse Counting Mode (100)

Up/Down Counting using pulses at the inputs of A and B

The counter counts up on the positive edge of the pulses at input A, and counts down on the positive edge of input B.

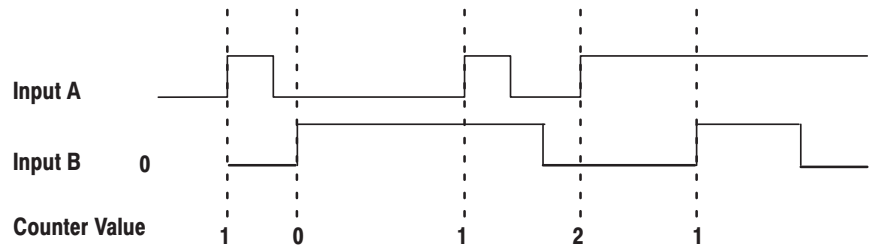
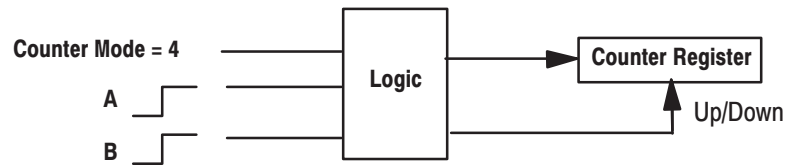

Count Pulses from Incremental Encoders

Pulse Counting Mode (001, 010, 011) Up/Down Counting using pulses at the inputs of A and B

If counter mode = 1, 2 or 3, then 1, 2 or 4 edges of the pulse train will be counted. The count direction (up/down) is determined by the phase difference of the input signals A and B.

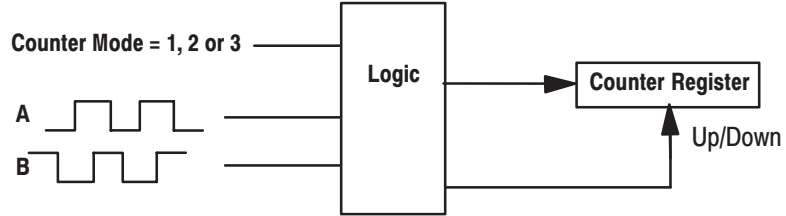

Example 1 - Counter Mode = 1 (x1)

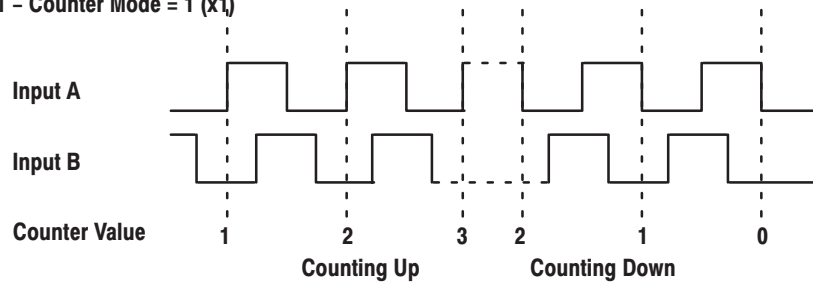

Example 2 - Counter Mode = 2 (x2)

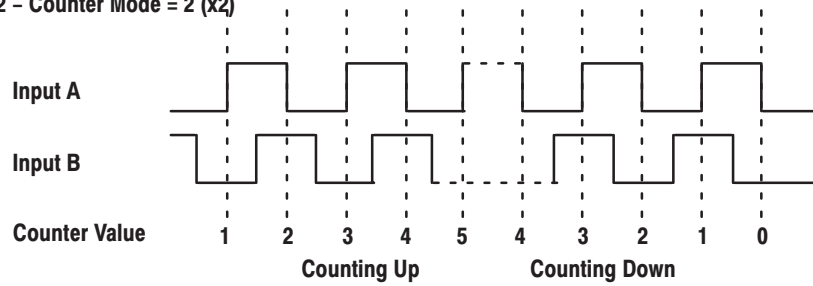

Example 3 - Counter Mode = 3 (x4)

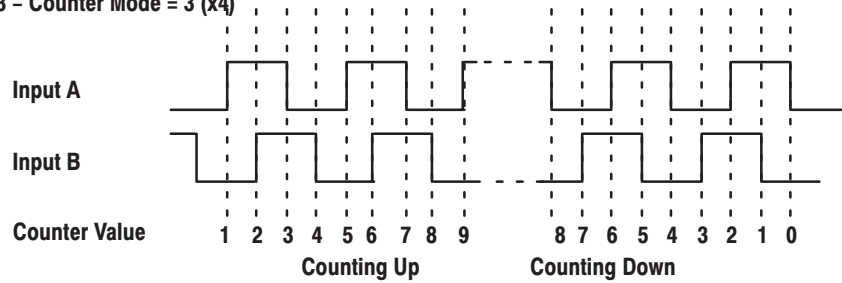

Preset Function

Use the preset function to copy a value from the preset register to the counter register.

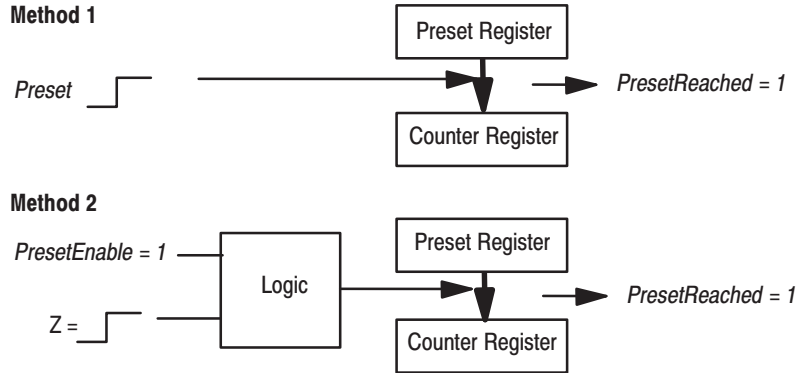

The flag PresetReached is set when the counter register and the preset register are equal (if the counter preset is reached, or if the counter has been loaded with the preset value). This flag is reset on a positive edge of PresetReset after the operation and can only be set after at least one additional counting pulse.

Gate Function

Use the gate function to determine when counting starts and stops. You can use this function to measure distance.

The parameter GateControl determines the gate function. The gate signal is connected to input G. It is a 2-bit binary code in write word 1 or 2, bits 09 and 10

Word 1 or 2	Gate Control Function				
	Bits 09-10	Binary	10	09	Gate Control bits
	0	0	0		No gate function on input G (Count is independent)
	1	0	1		Counting only if G = 1 (active)
	2	1	0		Counting only if G = 0 (inactive)
	3	1	1		Calibration if G = 1 and all other conditions are fulfilled (refer to Calibrating the Module, chapter ?).

Example

Gate Control = 1

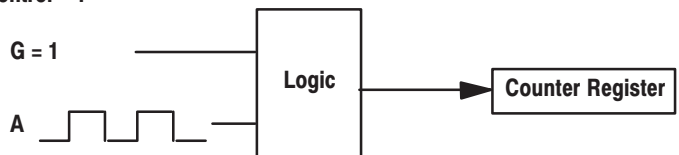

The counter is counting if G = 1.

Store Function

Use the store function to copy the value in the counter register (*Counter*) to the latch register (*StoreValue*).

The *StoreControl* parameter determines the store function. Execution occurs on either the positive or negative edge of input signals *G* and *Z* respectively (see table). The parameter is a 2-bit binary code in write word 1 (bits 11 and 12)

Word 1 or 2	Bits 11-12	Binary	12	11	Store Control bits
		0	0	0	Save the counter value on the positive edge of Z (if Stored X = 0)
		1	0	1	Save the counter value on the positive edge of G (if Stored X = 0)
		2	1	0	Save the counter value on the negative edge of G (if Stored X = 0)
		3	1	1	Save the counter value on both the positive edge and negative edge of G (if Stored X = 0)

The parameter *Stored* must be reset (0). *Stored* is set (1) when the operation is completed. Reset after the operation with *StoreReset*.

Example

Store Control = 1

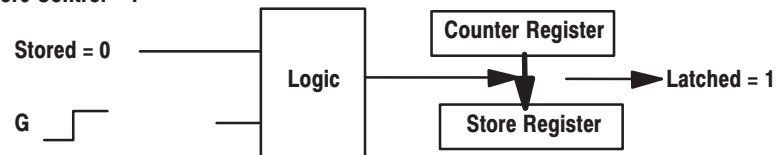

The counter value is copied to the store register on the positive edge of input signal *G*.

Limitation Function

If the control bit *RangeLimited* = 1, the counter counts up to the preset value and restarts at 0. Counting down, the counter reaches the preset value on the next pulse if the current counter value = 0.

RangeLimited = 0 corresponds to *RangeLimited* = 1 if the preset value = FFFF in hex = 65535 in decimal.

The flag *PresetReached* is set when the counter is equal to the preset value. Use *PresetReset* to reset the flag.

Count Up pulse (+)

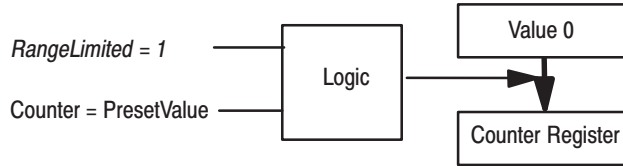

Count Down pulse (-)

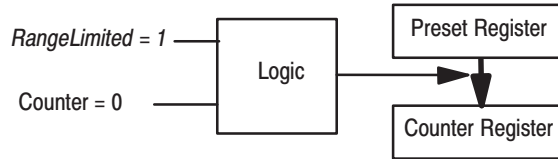

Note: If the preset register value = 0, the counter retains the value 0.

Filter Function

The filter function is only valid during mode 000 (pulse counting). You enable the filter function by setting bits in Control word 2. Each counter can be individually filtered by enabling its associated filter control bit. However the filter is common to both counters.

When a counter is in mode 000 and its filter is enabled, signal A is internally sampled at a rate 8 times higher than the filter constant. A change of state in A has to be valid during 4 samples before it reaches the counter.

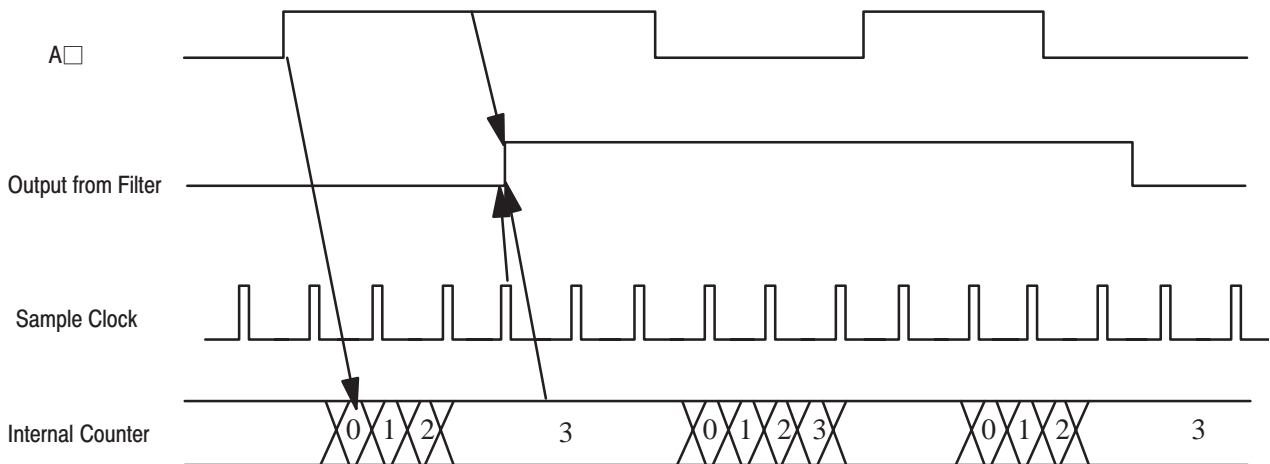

Chapter Summary

In this chapter, you learned about the incremental encoder module, block transfer communication, and details of how the module functions. Now you can install the module.

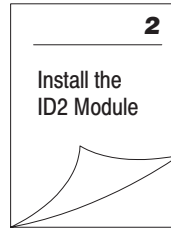

How to Install Your Incremental Encoder Module

What This Chapter Contains

In this chapter, we tell you about:

For information on	See page
Before You Install Your Module	2-1
European Union Directives	2-1
Power Requirements	2-2
Installing the Module	2-4
on a DIN rail	2-4
on a wall/panel	2-6
on the terminal base	2-7
Connecting Wiring	2-9
Module Indicators	2-14

Before You Install Your Input Module

Before installing your incremental encoder module in the FLEX I/O system:

You need to:	As described under:
Calculate the power requirements of all modules in each FLEX system.	Power Requirements, page 2-2
Position the keyswitch on the terminal base	Installing the Module, page 2-4



ATTENTION: The incremental encoder module does not receive power from the backplane. +24V dc power must be applied to your module before installation. If power is not applied, the module position will appear to the adapter as an empty slot in your chassis.

European Union Directive Compliance

If this product has the CE mark it is approved for installation within the European Union and EEA regions. It has been designed and tested to meet the following directives.

EMC Directive

This product is tested to meet Council Directive 89/336/EEC Electromagnetic Compatibility (EMC) and the following standards, in whole or in part, documented in a technical construction file:

- EN 50081-2EMC – Generic Emission Standard, Part 2 – Industrial Environment
- EN 50082-2EMC – Generic Immunity Standard, Part 2 – Industrial Environment

This product is intended for use in an industrial environment.

Low Voltage Directive

This product is tested to meet Council Directive 73/23/EEC Low Voltage, by applying the safety requirements of EN 61131-2 Programmable Controllers, Part 2 – Equipment Requirements and Tests.

For specific information required by EN 61131-2, see the appropriate sections in this publication, as well as Allen-Bradley publication 1770-4.1, Industrial Automation Wiring and Grounding Guidelines.

Open style devices must be provided with environmental and safety protection by proper mounting in enclosures designed for specific application conditions. See NEMA Standards publication 250 and IEC publication 529, as applicable, for explanations of the degrees of protection provided by different types of enclosure.

Power Requirements

The wiring of the terminal base unit is determined by the current draw through the terminal base. Make certain that the current draw does not exceed 10A.



ATTENTION: Total current draw through the terminal base unit is limited to 10A. Separate power connections may be necessary.

Methods of wiring the terminal base units are shown in the illustration below.

Wiring the Terminal Base Units (1794-TB3G shown)



ATTENTION: Do not daisy chain power or ground from the terminal base unit to any ac or dc digital module terminal base unit.

Daisy-chaining

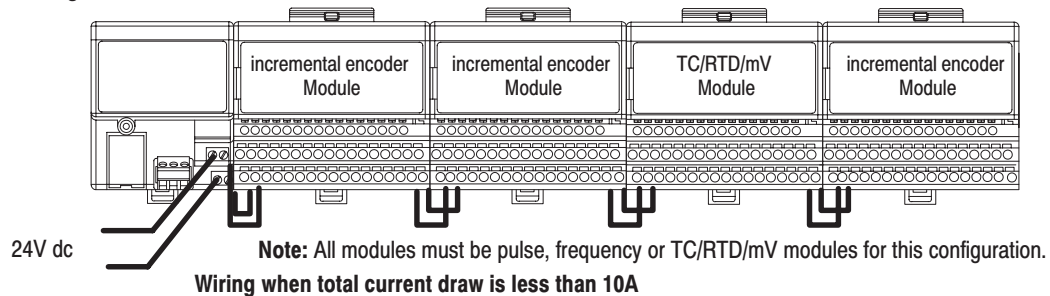

Individual

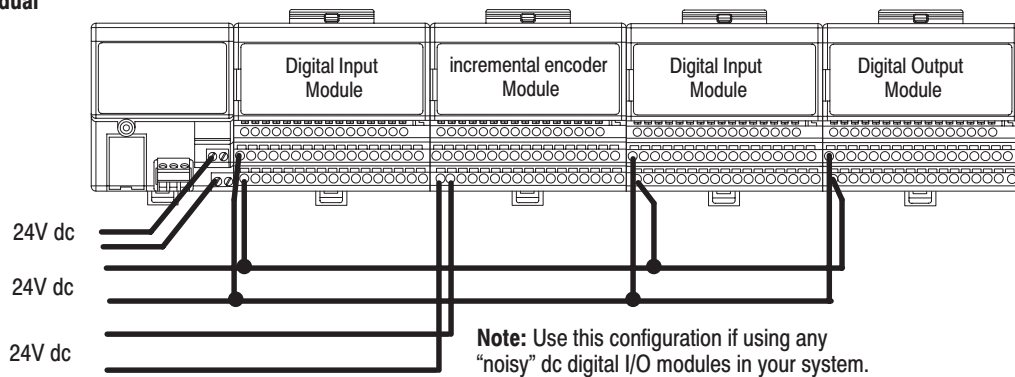

incremental encoder Module wiring separate from digital wiring.

Wiring when total current draw is greater than 10A

Combination

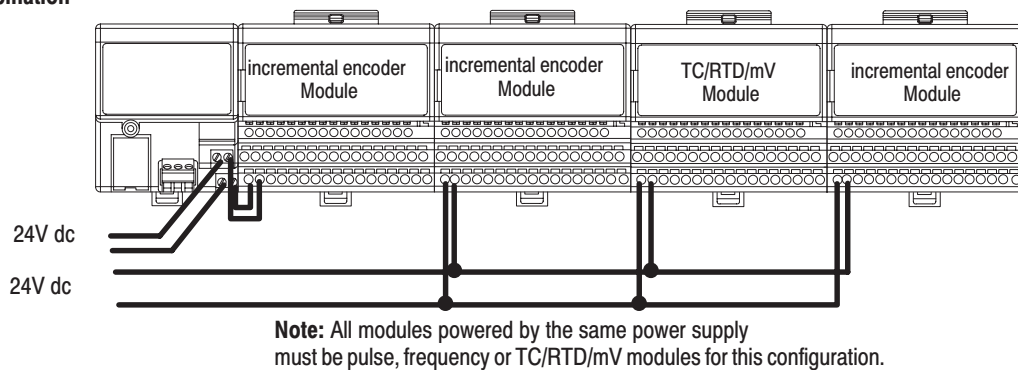

Total current draw through any base unit must not be greater than 10A

Installing the Module

Installation of the incremental encoder module consists of:

- mounting the terminal base unit
- installing the module into the terminal base unit
- installing the connecting wiring to the terminal base unit

If you are installing your module into a terminal base unit that is already installed, proceed to “Mounting the incremental encoder Module on the Terminal Base” on page 2-7.

Mounting the Terminal Base Unit on a DIN Rail



ATTENTION: Do not remove or replace a terminal base unit when power is applied. Interruption of the flexbus can result in unintended operation or machine motion.

1. Remove the cover plug (if used) in the male connector of the unit to which you are connecting this terminal base unit.
2. Check to make sure that the 16 pins in the male connector on the adjacent device are straight and in line so that the mating female connector on this terminal base unit will mate correctly.
3. Position the terminal base on the 35 x 7.5mm DIN rail **A** (A-B pt. no. 199-DR1; 46277-3). Proceed as follows:

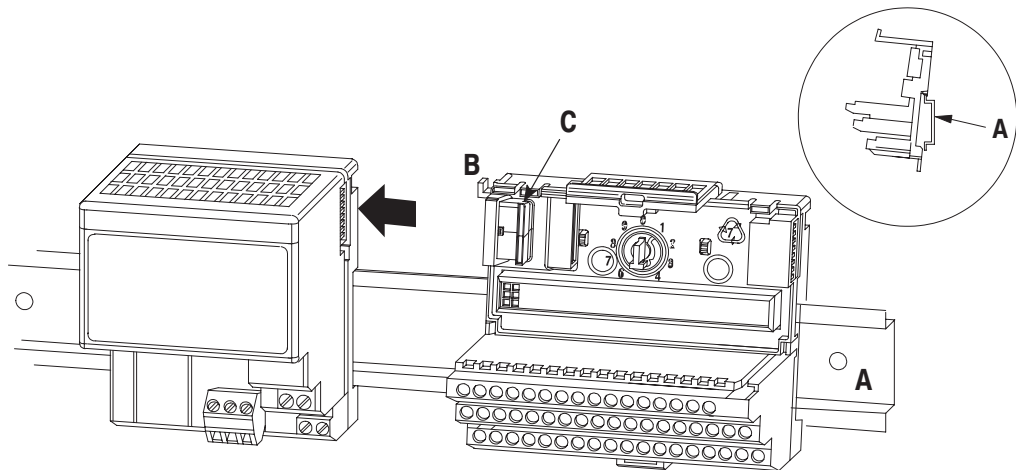

Position terminal base at a slight angle and hooked over the top of the DIN rail.

4. Make certain that the female flexbus connector **C** is **fully retracted** into the base unit.

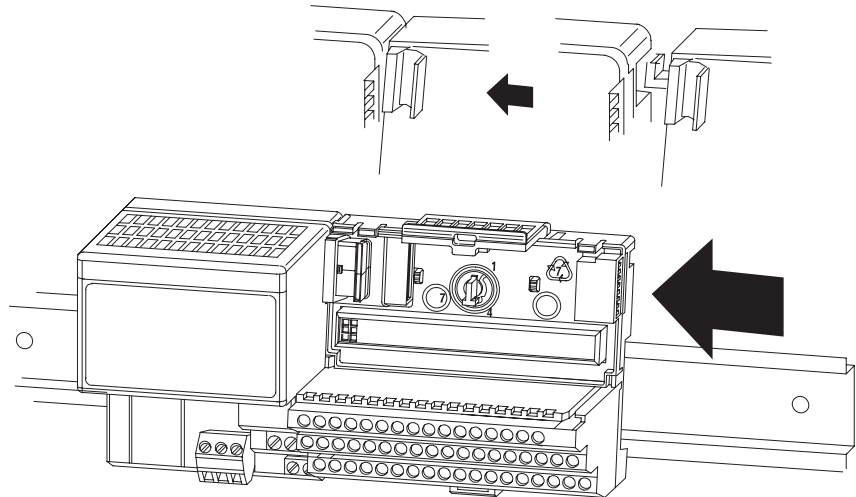

Slide the terminal base unit over tight against the adapter. Make sure the hook on the terminal base slides under the edge of the adapter and the flexbus connector is fully retracted.

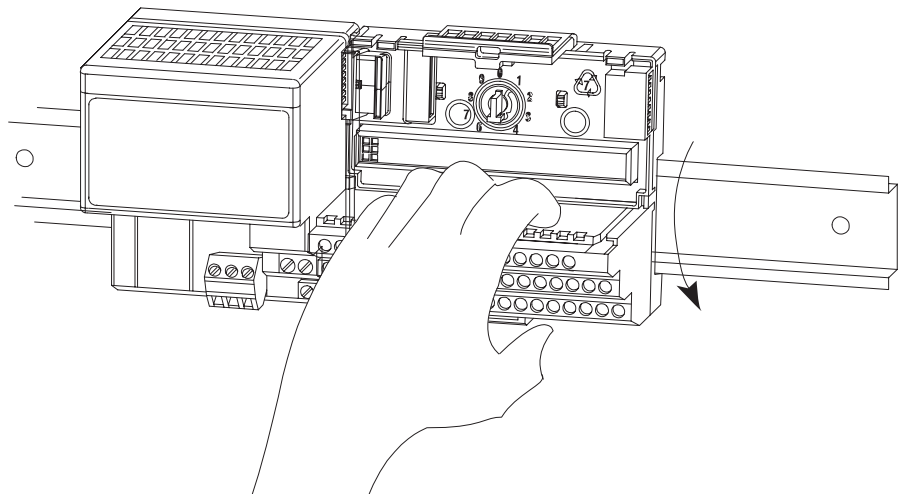

Press down on the terminal base unit to lock the terminal base on the DIN rail. If the terminal base does not lock into place, use a screwdriver or similar device to open the locking tab, press down on the terminal base until flush with the DIN rail and release the locking tab to lock the base in place.

30077-M

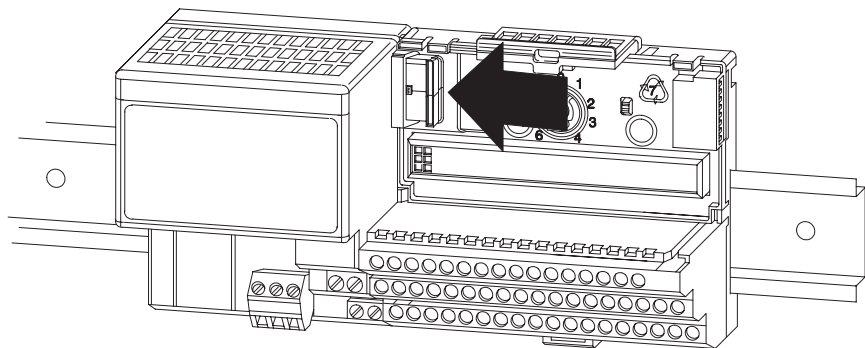

Gently push the flexbus connector into the side of the adapter to complete the backplane connection.

5. Repeat the above steps to install the next terminal base.

Panel/Wall Mounting

Installation on a wall or panel consists of:

- laying out the drilling points on the wall or panel
- drilling the pilot holes for the mounting screws
- mounting the adapter mounting plate
- installing the terminal base units and securing them to the wall or panel

If you are installing your module into a terminal base unit that is already installed, proceed to “Mounting the incremental encoder Module on the Terminal Base” on page 2-7.

Use the mounting kit Cat. No. 1794-NM1 for panel/wall mounting.

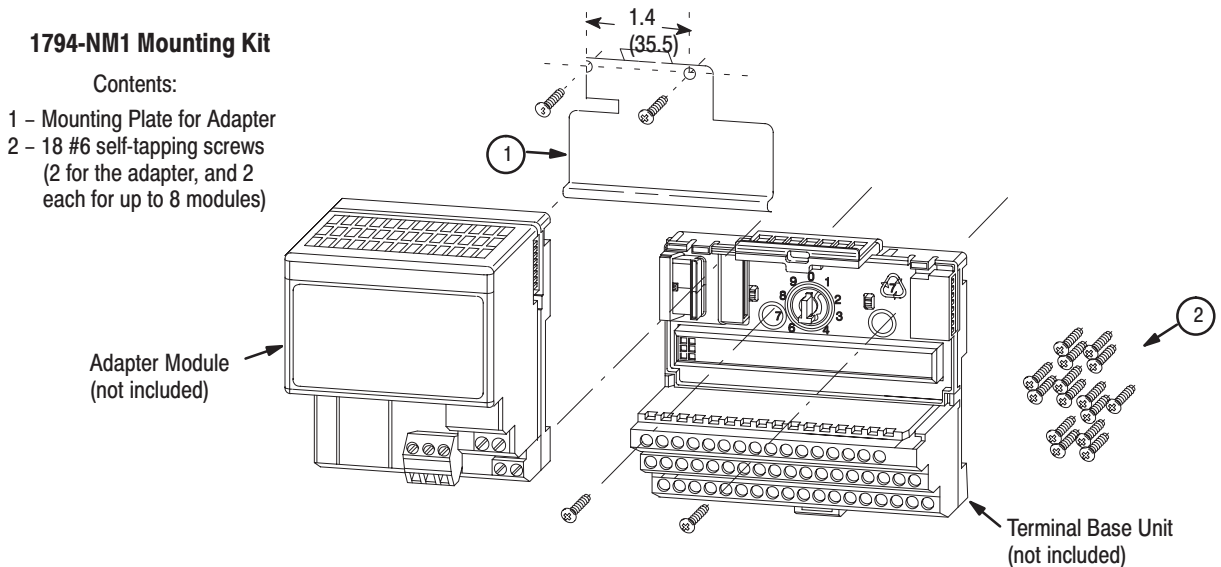

To install the mounting plate on a wall or panel:

1. Lay out the required points on the wall/panel as shown in the drilling dimension drawing.

Drilling Dimensions for Panel/Wall Mounting of FLEX I/O

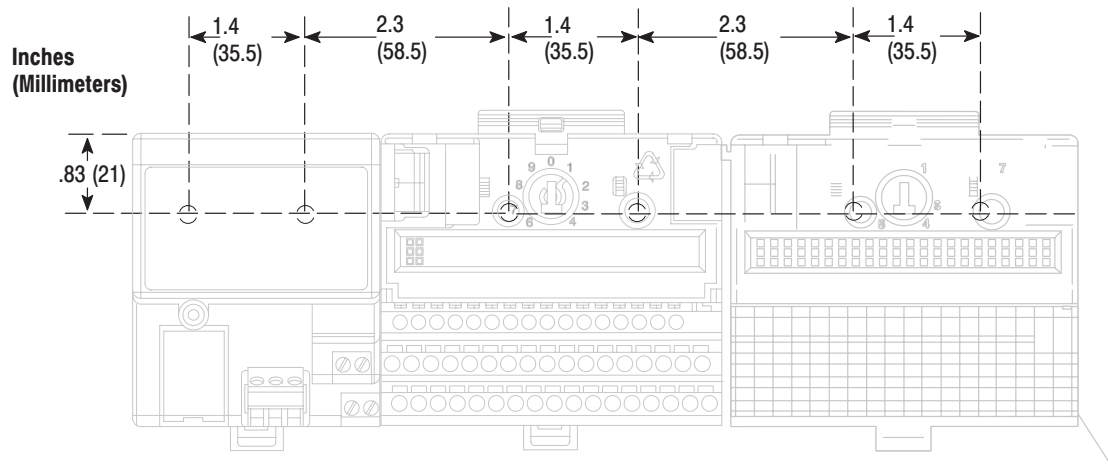

2. Drill the necessary holes for the #6 self-tapping mounting screws.
3. Mount the mounting plate (1) for the adapter module using two #6 self-tapping screws (18 included for mounting up to 8 modules and the adapter).

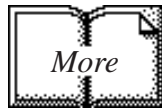

- Important:** Make certain that the mounting plate is properly grounded to the panel. Refer to “Industrial Automation Wiring and Grounding Guidelines,” publication 1770-4.1.
4. Hold the adapter (2) at a slight angle and engage the top of the mounting plate in the indentation on the rear of the adapter module.
 5. Press the adapter down flush with the panel until the locking lever locks.
 6. Position the terminal base unit up against the adapter and push the female bus connector into the adapter.
 7. Secure to the wall with two #6 self-tapping screws.
 8. Repeat for each remaining terminal base unit.

Note: The adapter is capable of addressing eight modules. Do not exceed a maximum of eight terminal base units in your system.

Mounting the Incremental Encoder Module on the Terminal Base Unit

The incremental encoder module mounts on a 1794-TB3, TB3S, -TBN or -TBNF terminal base unit.

1. Rotate the keyswitch (1) on the terminal base unit (2) clockwise to position 1 as required for the incremental encoder module.

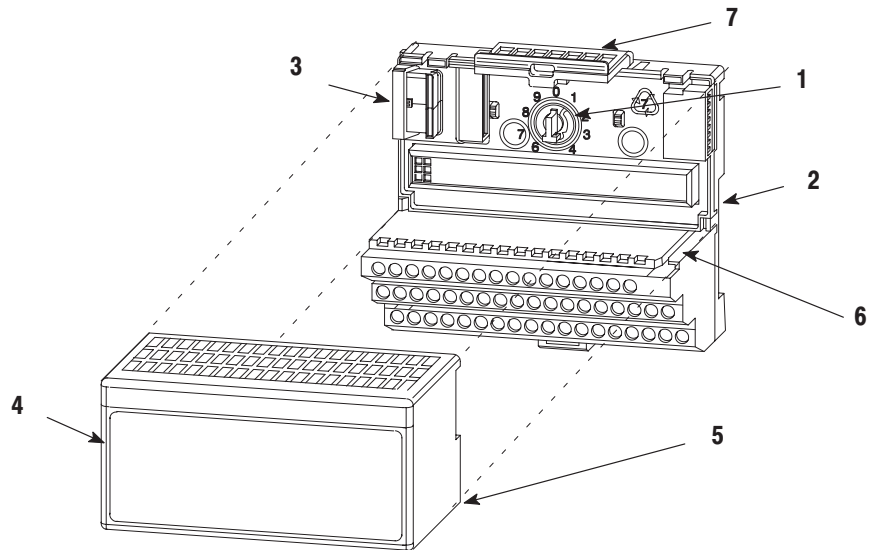

2. Make certain the flexbus connector (3) is pushed all the way to the left to connect with the neighboring terminal base/adaptor. **You cannot install the module unless the connector is fully extended.**
3. Make sure that the pins on the bottom of the module are straight so they will align properly with the connector in the terminal base unit.



ATTENTION: Remove field-side power before removing or inserting the module. This module is designed so **you can remove and insert it under backplane power**. When you remove or insert a module with field-side power applied, an electrical arc may occur. An electrical arc can cause personal injury or property damage by:

- sending an erroneous signal to your system's field devices causing unintended machine motion
 - causing an explosion in a hazardous environment
- Repeated electrical arcing causes excessive wear to contacts on both the module and its mating connector. Worn contacts may create electrical resistance.

4. Position the module (4) with its alignment bar (5) aligned with the groove (6) on the terminal base.
5. Press firmly and evenly to seat the module in the terminal base unit. The module is seated when the latching mechanism (7) is locked into the module.
6. Repeat the above steps to install the next module in its terminal base unit.

Connecting Wiring for Your incremental encoder Module

Wiring to the module is made through the terminal base unit on which the module mounts.

Compatible terminal base units are:

Module	1794-TB3	1794-TB3S	1794-TBN	1794-TBNF
1794-ID2	Yes	Yes	Yes	Yes

1794-TB3

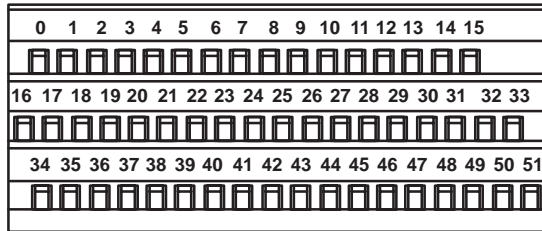

34 and 50 = 24V dc
 35 and 51 = common
 16 and 33 = chassis ground
 40 thru 45 = chassis ground

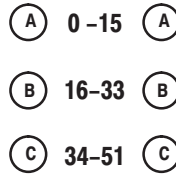

1794-TB3S

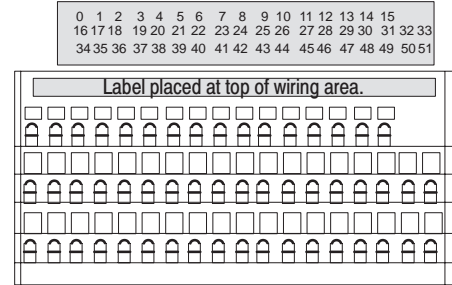

34 and 50 = 24V dc
 35 and 51 = common
 16 and 33 = chassis ground
 40 thru 45 = chassis ground

Connecting Wiring using a 1794-TB3 and -TB3S Terminal Base Units

1. Connect individual input wiring (A+, A-, B+, B-, Z+, Z-, G+, G-) to numbered terminals on the 0-15 row (A) as indicated in the table below.



ATTENTION: Do not connect maximum input voltage simultaneously to all inputs if the module ambient temperature is expected to exceed 40°C.



ATTENTION: If the module ambient temperature is expected to continuously exceed 40°C, you must limit the input voltage using an external resistor on each input. A 1KΩ resistor effectively limits a 24V sensor signal to about 15V at the input. Do not limit the input to less than 6V.

2. Connect the associated input common (3-wire devices only) to the corresponding terminal on the 16-33 row (B) for each input as indicated in the table below. (Commons are internally connected together.)

3. Terminate shields to terminals 16 or 33 on row **B**, or 40 through 45 on row **C**.
4. Connect +24V dc to terminal 34 on the **34-51** row (**C**).
5. Connect dc return to terminal 16 on the **16-33** row (**B**).



ATTENTION: To reduce susceptibility to noise, power frequency modules and digital modules from separate power supplies. Do not exceed a length of 33 ft (10m) for dc power cabling.

6. If continuing power to the next terminal base unit, connect a jumper from terminal 51 (+24V dc) on this base unit to terminal 34 on the next base unit.
7. If continuing common to the next terminal base unit, connect a jumper from terminal 33 (common) on this base unit to terminal 16 on the next base unit.



ATTENTION: Do not daisy chain power or ground from this terminal base unit to any ac or dc digital module terminal base unit.



ATTENTION: This module does not receive power from the backplane. +24V dc power must be applied to your module before operation. If power is not applied, the module position will appear to the adapter as an empty slot in your chassis. If the adapter does not recognize your module after installation is completed, cycle power to the adapter.

Wiring to a 1794-TBN or -TBNF Terminal Base Unit

1. Connect individual input wiring (A+, A-, B+, B-, Z+, Z-, G+, G-) to the even numbered terminals on row (B) as indicated in the table below.



ATTENTION: Do not connect maximum input voltage simultaneously to all inputs if the module ambient temperature is expected to exceed 40°C.



ATTENTION: If the module ambient temperature is expected to continuously exceed 40°C, you must limit the input voltage using an external resistor on each input. A 1KΩ resistor effectively limits a 24V sensor signal to about 15V at the input. Do not limit the input to less than 6V.

2. Connect the associated input common to the corresponding odd numbered terminal on row (C) for each input as indicated in the table below.
3. Connect 24V dc to terminal 34 on row (C).
4. Connect 24V dc common to terminal 16 on row (B).
5. If continuing power to the next terminal base unit, connect a jumper from terminal 51 (24V dc) on this base unit to terminal 34 on the next base unit.
6. If continuing common to the next terminal base unit, connect a jumper from terminal 33 (24V dc common) on this base unit to terminal 16 on the next base unit.

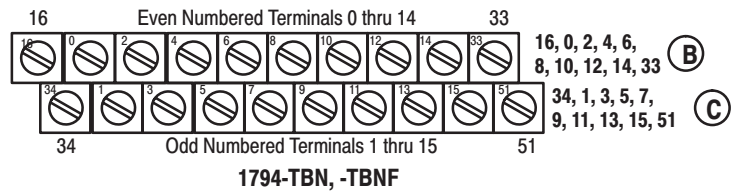

Wiring connections for the 1794-ID2 incremental encoder Module

	Terminal Base Units 1794-TB3, -TB3S			Terminal Base Units 1794-TBN, -TBNF ¹	
	Signal	0V dc	12/24V dc	Signal	Input
incremental encoder Channel 0					
A+	0	17	35	0	
A-	1	18	36	1	
B+	2	19	37	2	
B-	3	20	38	3	
Z+	4	21	39	4	
Z-	5	22	40	5	
G+	6	23	41	6	
G-	7	24	42	7	
incremental encoder Channel 1					
A+	8	25	43	8	
A-	9	26	44	9	
B+	10	27	45	10	
B-	11	28	46	11	
Z+	12	29	47	12	
Z-	13	30	48	13	
G+	14	31	49	14	
G-	15	32	50	15	
0V dc	Terminals 16 and 33 (1794-TB2) Terminals 16 thru 33 (1794-TB3, -TB3S)			Terminals 16 and 33	
12/24V dc	Terminals 34 thru 51 (1794-TB3, -3S)			Terminals 34 and 51	

¹ Auxiliary terminal blocks are required when using these terminal base units.



ATTENTION: Total current draw through the terminal base unit is limited to 10A. Separate power connections to the terminal base unit may be necessary.

Example of Pulse Transmitter Wiring

incremental encoder Channel 0

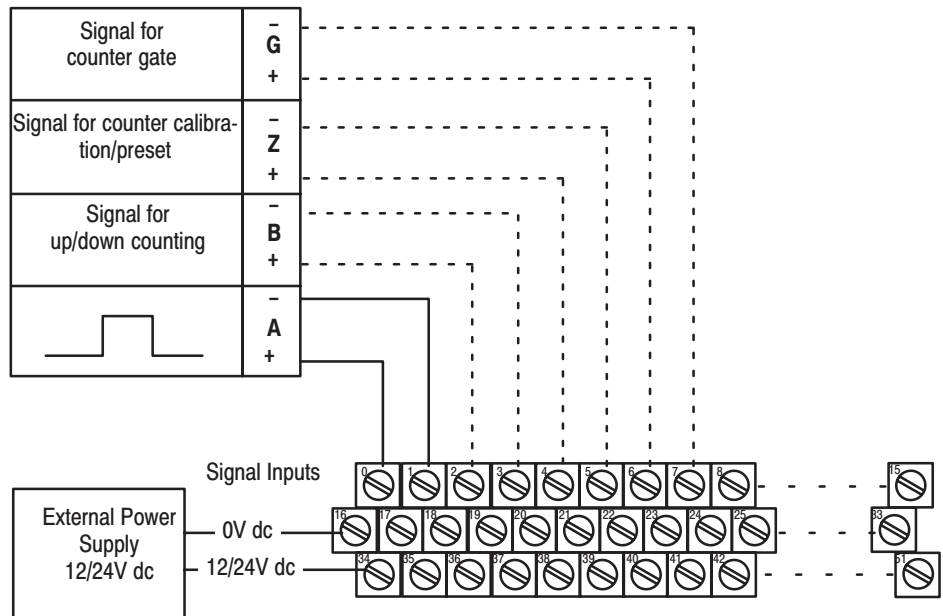

Example of pulse transmitter with 1 pulse train. For connection of channel 1, refer to wiring table.

Note: Dotted lines indicate signals not always used.

Example of Incremental Encoder Wiring

incremental encoder Channel 0

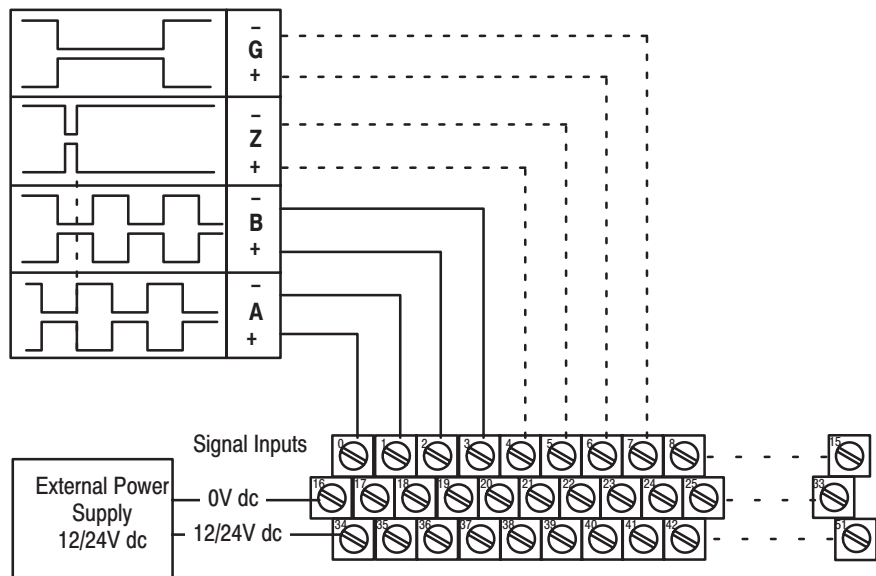

Example of incremental encoder with 2 pulse trains, with or without reference, and/or gate function. For connection of channel 1, refer to wiring table.

Note: Dotted lines indicate signals not always used.

Module Indicators

The incremental encoder module has one status indicator (PWR) that is on when power is applied to the module, and one input status indicator for each input (12 in all).

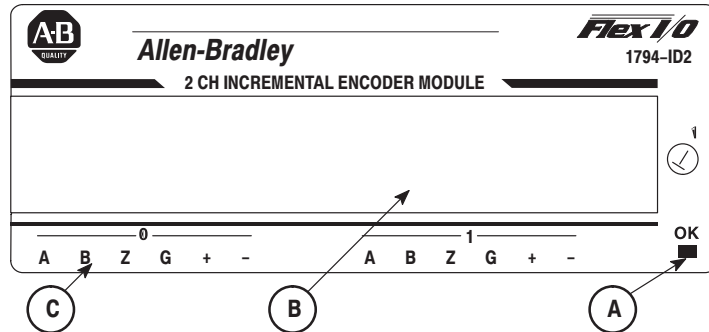

A = Power/status indicator – indicates power applied to module and status of module.

B = Insertable label for writing individual I/O assignments.

C = Status Indicators –

A = Status of input A

B = Status of input B

Z = Status of input Z

G = Status of input G

+ = Positive count detected

- = Negative count detected

Indicator	Indication	Explanation
A	Yellow	Input A active
	Off	Input A not active
B	Yellow	Input B active
	Off	Input B not active
Z	Yellow	Input Z active
	Off	Input Z not active
G	Yellow	Input G active
	Off	Input G not active
+	Yellow	On when a positive pulse is detected; turns off on negative pulse.
-	Yellow	On when a negative pulse is detected; turns off on positive pulse.
OK	Red	Red during initialization after power turned on
	Green	Green when initialization is completed

Chapter Summary

In this chapter, we told you how to install your incremental encoder module in an existing programmable controller system and how to wire to the terminal base units.

Programming Your Incremental Encoder Module

What This Chapter Contains

To initiate communication between the incremental encoder module and your PLC processor, you must enter block transfer instructions into your ladder logic program. Use this chapter to enter the necessary block transfer instructions into your ladder logic program.

To edit your ladder logic you	See page
Enter Block Transfer Instructions	3-1
PLC-2 Family Processors	3-2
PLC-5 Family Processors	3-2
SLC-5 Processors	3-3

Enter Block Transfer Instructions

The incremental encoder module communicates with the PLC processor through bidirectional block transfers. This is the sequential operation of both read and write block transfer instructions.

Before you configure the module, you need to enter block transfer instructions into your ladder logic. The following example programs illustrate the minimum programming required for communication to take place between the module and a PLC processor. These programs can be modified to suit your application requirements.

A configuration block transfer write (BTW) is initiated when the module is first powered up, and subsequently only when the programmer wants to enable or disable features of the module. The configuration BTW sets the bits which enable the programmable features of the module, such as scalars and alarm values, etc. Block transfer reads are performed to retrieve information from the module.

Block transfer read (BTR) programming moves status and data from the module to the processor's data table. The processor user program initiates the request to transfer data from the module to the processor. The transferred words contain module status, channel status and input data from the module.

Your program should monitor status bits, block transfer read and block transfer write activity.

PLC-2 Family Processor

The 1794 incremental encoder module is not recommended for use with PLC-2 family programmable controllers due to the number of digits needed for high resolution.

Important: The incremental encoder module functions with reduced performance in PLC-2 systems. Because the module does not support BCD and the PLC-2 processor is limited to values of 4095 (12 bit binary), many values returned in the BTR file may not provide meaningful data to the PLC-2 processor.

PLC-5 Family Processor

Block transfer instructions with the PLC-5 processor use a control file and a data file. The block transfer control file contains the data table section for module location, the address of the block transfer data file and other related data. The block transfer data file stores data that you want transferred to the module (when programming a BTW) or from the module (when programming a BTR).

The programming terminal prompts you to create a control file when a block transfer instruction is being programmed. **A different block transfer control file is used for the read and write instructions for your module.**

PLC-5 Processor
Program Example

Rung 2:0

The ID2 module is located in rack 1, I/O group 0, slot 0. The integer control file starts at N17:0. The data sent by the PLC-5 processor to the ID2 module starts at N18:0 and is 4 words long. At power up in RUN mode, or when the processor is first switched from PROG to RUN, the user program enables a block transfer write to configure the module..

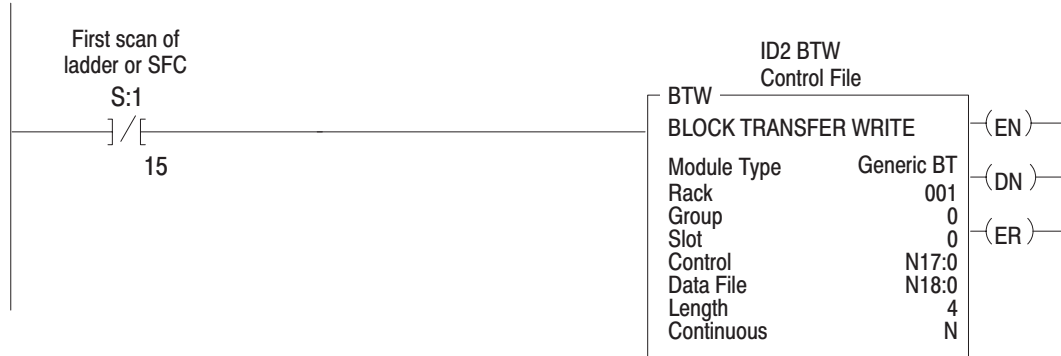

Rung 2:1

The ID2 module is located in rack 1, group 2, slot 0. The integer control file starts at N17:10,. The data obtained by the PLC-5 processor from the ID2 module is placed in memory starting at N18:10 and is 8 words long. IThe program continuously performs read block transfers to read data from the module.

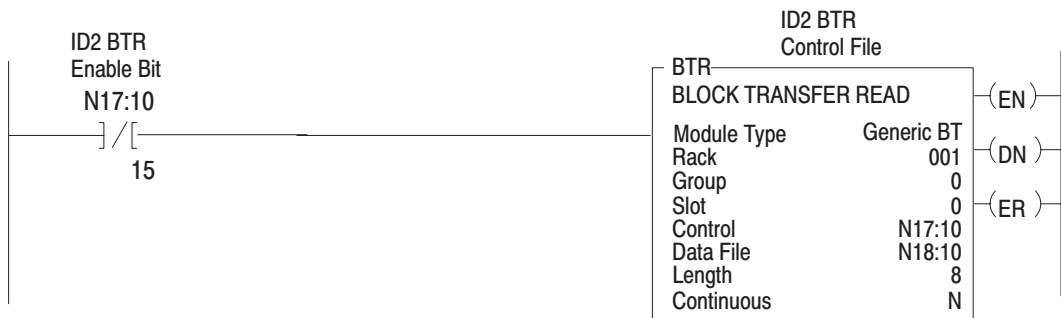

SLC-5 Programming

The SLC-5 programs (using the 1747-SN scanner) follow the same logic as the PLC-5 family programs in the previous example. Differences occur in the implementation of block transfers due to the use of “M” files in the SLC system.

Configuration data for the FLEX I/O incremental encoder module and the 1747-SN scanner must be in place before executing the following programs. Chapter 4 contains information on module configuration.

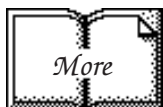

For more information on using the 1747-SN scanner module and block transfer programming, refer to publication 1747-6.6, “Remote I/O Scanner User Manual.”

Figure 3.1 SLC Programming for the 1794-OF4I Isolated Analog Output Module

Program Action

This rung configures the block transfer operation type, length, and RIO address at power-up. Bit B3:100/7 must be set to 1 to indicate a BTR and bit B3:110/7 must be 0 to indicate a BTW.

BTR status is copied to the B3:0 area when a BTR is in progress.

Unlatch the bit that continues to check the BTR status.

BTW status is copied to the B3:100 area when a BTW is in progress.

Unlatch the bit that continues to check the BTW status.

To next page.

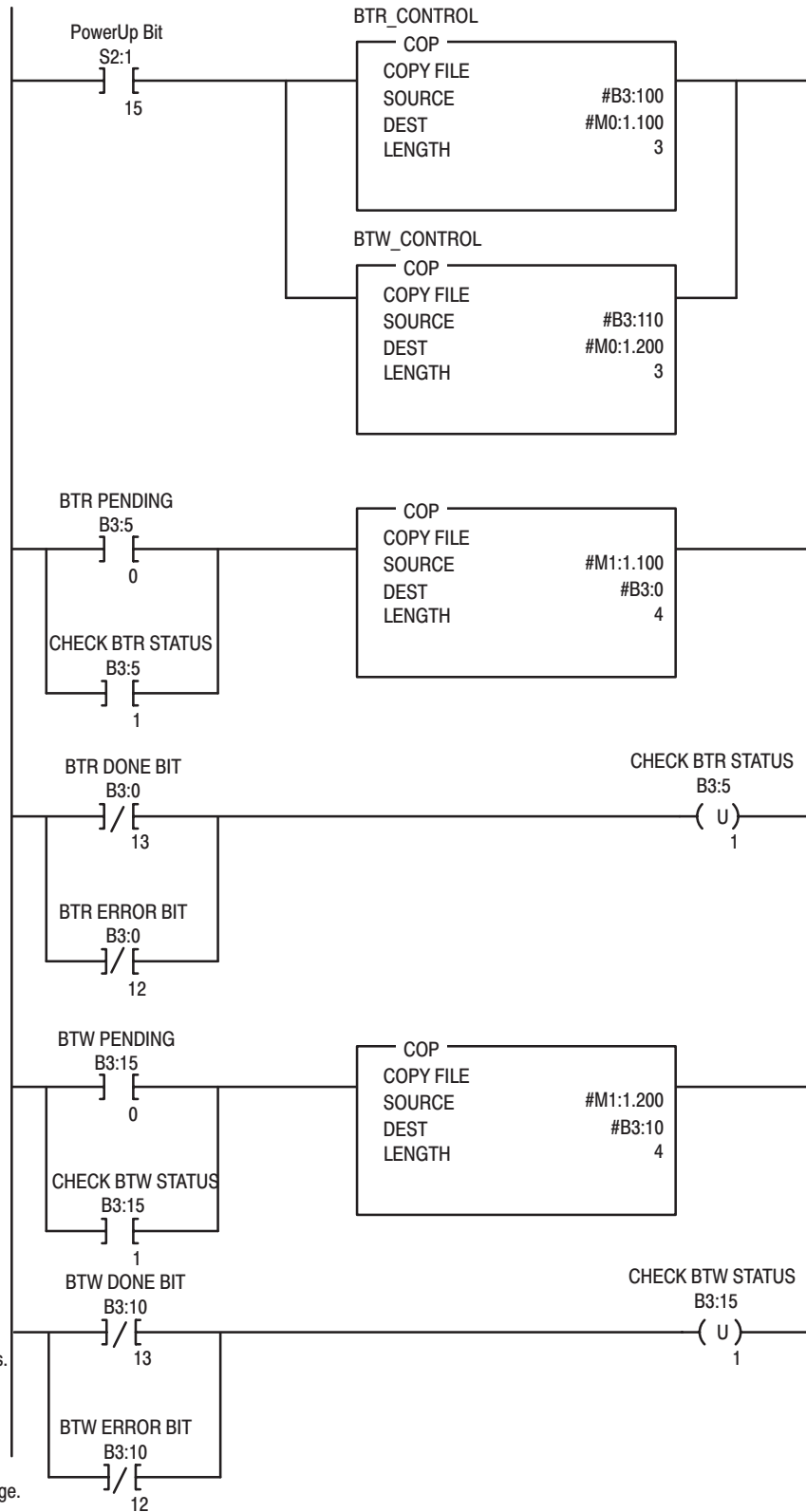

Program Action

When a BTR successfully completes and the done bit is detected, the BTR data is copied into the N7:0 to N7:7 area.

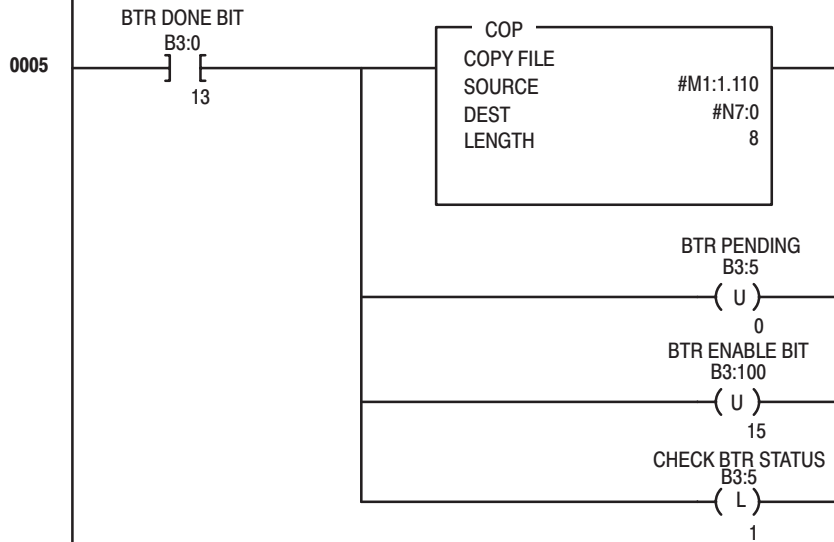

When a BTR error occurs, the error code is moved to N7:9.

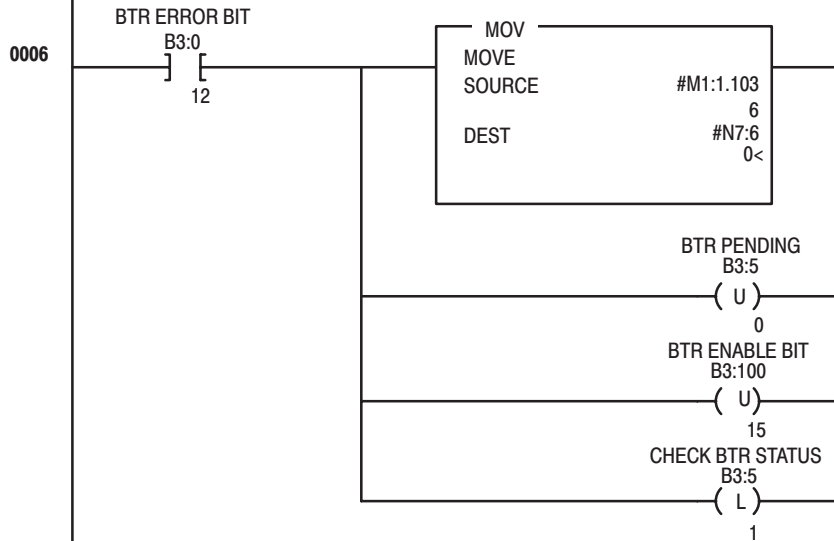

When a BTW successfully completes and the done bit is detected, the BTR data is copied into the N7:0 to N7:7 area.

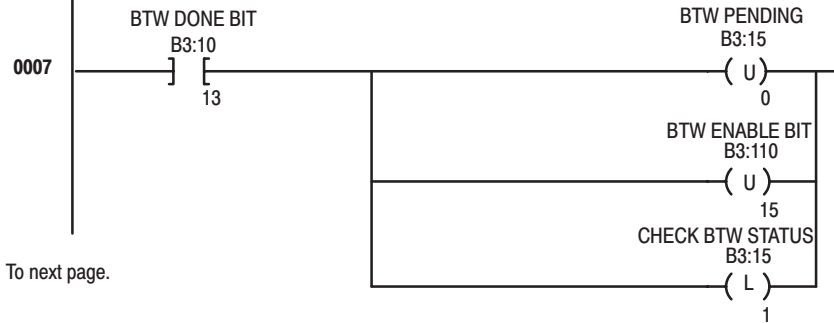

To next page.

Program Action

When a BTW occurs, the error code is moved to N7:17.

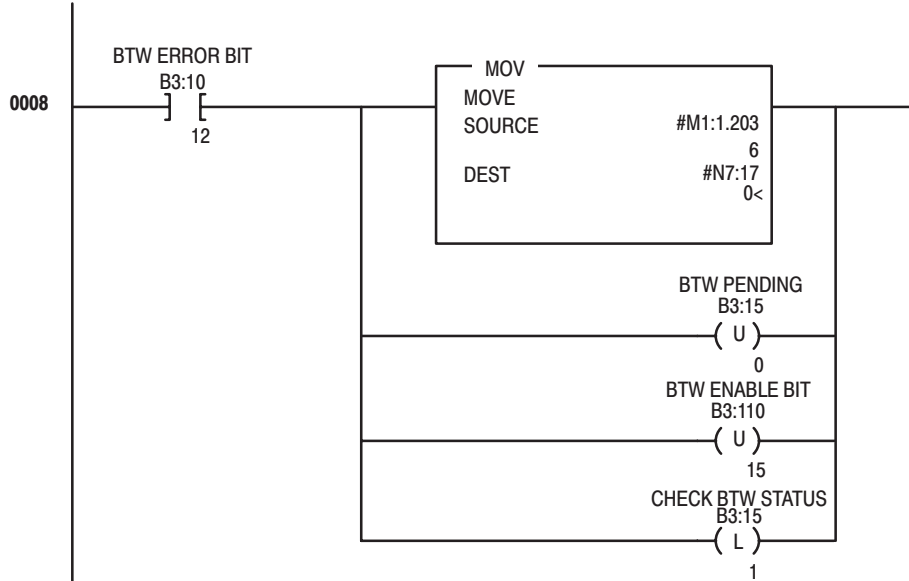

This rung executes BTRs continuously, as fast as possible.

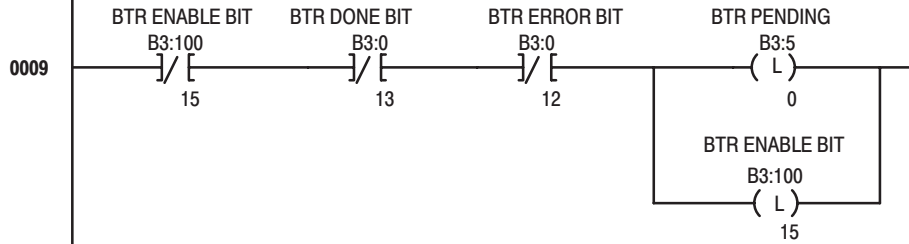

One BTW is triggered at power up. Four words of data starting at N7:10 is sent to the 1794-ID2 module.

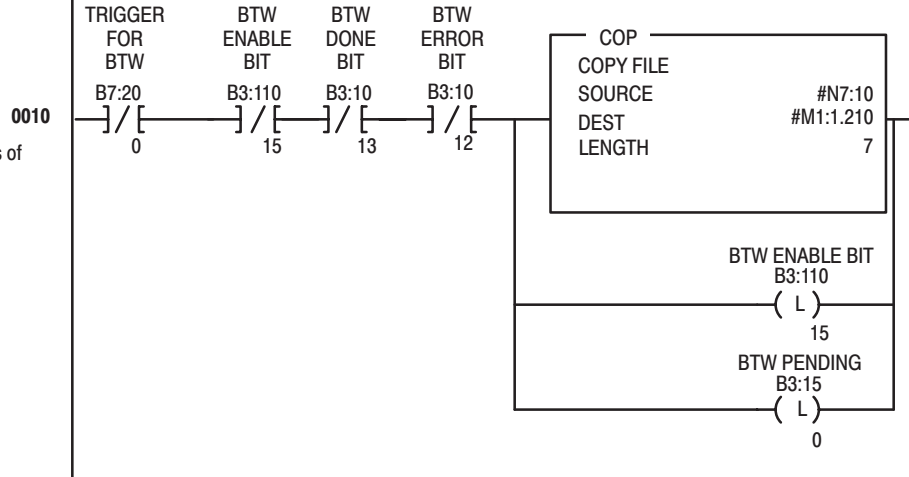

To next page.

Program Action

This BTR control word is moved to the M0 file for the scanner module while the BTR is in progress until the enable, done and error bits are turned off

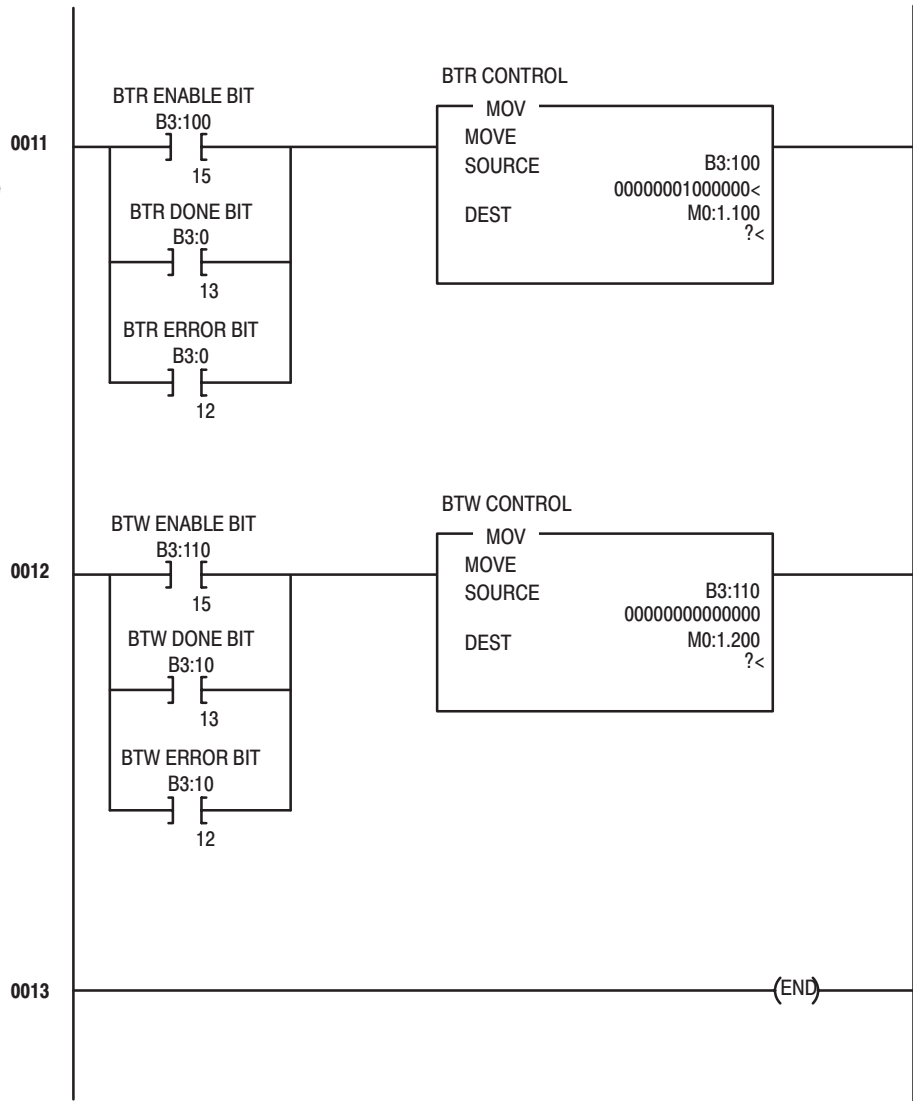

This BTW control word is moved to the M0 file for the scanner module while the BTW is in progress until the enable, done and error bits are turned off.

Chapter Summary

In this chapter, you learned how to program your ID2 incremental encoder module using block transfer instructions and ladder logic. Now, you can configure your module.

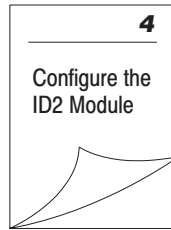

Writing Configuration to and Reading Status from Your Module with a Remote I/O Adapter

What This Chapter Contains

In this chapter, we tell you about:

For information on	See page
Configuring Your Module	4-1
Reading Data from Your Module	4-2
Mapping Data for the Module	4-2
Incremental Encoder Module (1794-ID2) Image Table Mapping	4-2
Block Transfer Read Word Assignments	4-3
Bit/Word Definitions for Block Transfer Read Words	4-3
Block Transfer Write Word Assignments	4-5
Bit/Word Definitions for the Block Transfer Write Words	4-5

Configuring Your Incremental Encoder Module

The incremental encoder module is configured using a group of data table words that are transferred to the module using a block transfer write instruction.

Some of the software configurable features available are:

- number of inputs
- encoder multiplier
- gate function
- latch function
- rollover

Configure your module for its intended operation by means of your programming terminal and write block transfers.

Note: Programmable controllers that use 6200 software (release 4.2 or higher) programming tools can take advantage of the IOCONFIG Addendum utility to configure this module. IOCONFIG Addendum uses menu-based screens for configuration without having to set individual bits in particular locations. Refer to your 6200 software literature for details.

Important: It is strongly recommended that you use IOCONFIG Addendum to configure this module. The IOCONFIG Addendum utility greatly simplifies configuration. If the IOCONFIG Addendum is not available, you must enter data directly into the data table. Use this chapter as a reference when performing this task.

During normal operation, the processor transfers from 1 to 4 words to the module when you program a BTW instruction to the module's address.

Reading Data From Your Module

Read programming moves status and data from the frequency input module to the processor's data table in one I/O scan. The processor's user program initiates the request to transfer data from the incremental encoder module to the processor.

Mapping Data for the Module

The following read and write words and bit/word descriptions describe the information written to and read from the incremental encoder module. The module uses up to 8 words of input data and up to 5 words of output data. Each word is composed of 16 bits.

Incremental Encoder Module (1794-ID2) Image Table Mapping

Module Image

R	PR1	PR0	S1	S0	C1	C0	G1	Z1	B1	A1	G0	Z0	B0	A0
Store 0 - Stored Counter Value on channel 0														
Store 1 - Stored Counter Value on channel 1														
Channel 0 - current counter value														
Channel 1 - current counter value														
Channel 0 - Counter word readback														
Channel 1 - Counter word readback														
Code for identification of software version														
Channel 0 Control Word - Sets the function of counter 0														
Channel 1 Control Word - Sets the function of counter 1														
Channel 0 Preset - value to load or compare with counter 0														
Preset 1 - value to load or compare with counter 1														
Control Word 2 - Sets filter function for both counters														

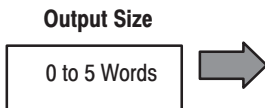
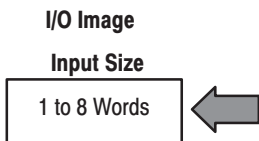

Block Transfer Read Word Assignments for the Incremental Encoder Module (1794-ID2)

(Octal Bit⇒)	17	16	15	14	13	12	11	10	07	06	05	04	03	02	01	00
Dec. Bit ⇒	15	14	13	12	11	10	09	08	07	06	05	04	03	02	01	00
Word↓	Read															
0	CTD1	CTD0	PR1	PR0	S1	S0	C1	C0	G1	Z1	B1	A1	G0	Z0	B0	A0
1	Channel 0 – Stored counter value on channel 0															
2	Channel 1 – Stored counter value on channel 1															
3	Channel 0 – current counter value on channel 0															
4	Channel 1 – current counter value on channel 1															
5	Channel 0 – Counter word readback															
6	Channel 1 – Counter word readback															
7	Revision read – software version code															

Where: A0 = Status of input A, channel 0 – bit = 1 when input is on
 B0 = Status of input B, channel 0 – bit = 1 when input is on
 Z0 = Status of input Z, channel 0 – bit = 1 when input is on
 G0 = Status of input G, channel 0 – bit = 1 when input is on
 G1 = Status of input G, channel 1 – bit = 1 when input is on
 A1 = Status of input A, channel 1 – bit = 1 when input is on
 B1 = Status of input B, channel 1 – bit = 1 when input is on
 Z1 = Status of input Z, channel 1 – bit = 1 when input is on
 C0 = Cal 0 – when bit is set, counter 0 has been calibrated (reset by CalReset)
 C1 = Cal 1 – when bit is set, counter 1 has been calibrated (reset by CalReset)
 S0 = Stored 0 – when bit is set, counter 0 value has been saved in Store 0 (reset by StoreReset)
 S1 = Stored 1 – when bit is set, counter 1 value has been saved in Store 1 (reset by StoreReset)
 Once a Store occurs, L0 and L1 are on until cleared by StoreReset (counter word bit 14)
 PR0 = Preset 0 reached – when bit is set, counter 0 has reached value of preset (reset by PresetReset)
 PR1 = Preset 1 reached – when bit is set, counter 1 has reached value of preset (reset by PresetReset)

Bit/Word Definitions for Block Transfer Read Words for the Incremental Encoder Module

Read Word	Bit	Definition
Word 0	Bit 00	Status for input A (pulse transmitter 0) – This bit, when set, indicates a signal at A.
	Bit 01	Status for input B (pulse transmitter 0) – This bit, when set, indicates a signal at B.
	Bit 02	Status for input Z (pulse transmitter 0) – This bit, when set, indicates a signal at Z.
	Bit 03	Status for input G (pulse transmitter 0) – This bit, when set, indicates a signal at G.
	Bit 04	Status for input A (pulse transmitter 1) – This bit, when set, indicates a signal at A.
	Bit 05	Status for input B (pulse transmitter 1) – This bit, when set, indicates a signal at B.

Read Word	Bit	Definition
Word 0 continued	Bit 06	Status for input Z (pulse transmitter 1) – This bit, when set, indicates a signal at Z.
	Bit 07	Status for input G (pulse transmitter 1) – This bit, when set, indicates a signal at G.
	Bit 08 (10)	Cal 0 – This bit, when set (1), indicates that counter 0 has been calibrated. This bit is reset by CalReset.
	Bit 09 (11)	Cal 1 – This bit, when set (1), indicates that counter 1 has been calibrated. This bit is reset by CalReset.
	Bit 10 (12)	Store 0 – This bit, when set (1), indicates a counter value is saved in store 0. This bit is reset by StoreReset.
	Bit 11 (13)	Store 1 – This bit, when set (1), indicates a counter value is saved in store 1. This bit is reset by StoreReset.
	Bit 12 (14)	Preset Reached 0 (PR0) – When this bit is set (1), in all configuration modes, the counter 0 value equals the preset 0 value, either in a positive or negative direction. This bit is reset by PresetReset0 and can only be set again after at least 1 more pulse.
	Bit 13 (15)	Preset Reached 1 (PR1) – When this bit is set (1), in all configuration modes, the counter 1 value equals the preset 1 value, either in a positive or negative direction. This bit is reset by PresetReset1 and can only be set again after at least 1 more pulse.
	Bit 14 (16)	CTD 0 – Count direction – Increase/decrease counter value of counter 0 set to 0 at startup. 0 = last pulse decreased counter value; 1 = last pulse increased counter value.
Bit 15 (17)	CTD 1 – Count direction – Increase/decrease counter value of counter 1 set to 0 at startup. 0 = last pulse decreased counter value; 1 = last pulse increased counter value.	
Word 1	Bits 00–15 (00–17)	Store 0 – Saved counter value on channel 0
Word 2	Bits 00–15 (00–17)	Store 1 – Saved counter value on channel 1
Word 3	Bits 00–15 (00–17)	Channel 0 Current Counter Value – Current value in counter 0
Word 4	Bits 00–15 (00–17)	Channel 1 Current Counter Value – Current value in counter 1
Word 5	Bits 00–15 (00–17)	Channel 0 Readback – Counter word readback – last value written to write word 0
Word 6	Bits 00–15 (00–17)	Channel 0 Readback – Counter word readback – last value written to write word 1
Word 7	Bits 00–15 (00–17)	Revision Read – identification of latest software version code

Block Transfer Write Word Assignments for the Incremental Encoder Module

(Octal Bit) ⇒	17	16	15	14	13	12	11	10	07	06	05	04	03	02	01	00
Dec. Bit ⇒	15	14	13	12	11	10	09	08	07	06	05	04	03	02	01	00
Word ↓	Write															
0	Channel 0 Control Word – Sets the function of counter 0															
1	Channel 1 Control Word – Sets the function of counter 1															
2	Channel 0 Preset – value to load or compare with counter 0															
3	Channel 1 Preset – value to load or compare with counter 1															
4	Control Word 2 – Sets the filter function for both counters															

Bit/Word Definitions for the Block Transfer Write Words for the Incremental Encoder Module

Write Word	Bit	Definition			
Write Word 0	0-15 (0-17)	Channel 0 Control Word – Control word for setting the function of counter 0.			
	Bits 00-02	02	01	00	Mode Selection bits
		0	0	0	Counting on positive (rising) edge of input signal A. (Up/dwn counting determined by B.)
		0	0	1	Quadrature encoder X1
		0	1	0	Quadrature encoder X2
		0	1	1	Quadrature encoder X4
		1	0	0	Counting up on the positive edge of input signal A, and down on positive edge of input signal B.
		1	0	1	No count function.
		1	1	0	No count function.
	1	1	1	No count function.	
	Bit 03	Preset (Reset) bit – A positive edge on this bit moves the value in Preset X to Counter X, independent of Preset Enable. NOTE: To use Preset as Reset, use a count value of 0000 in the Preset value word.			
	Bit 04	Enable Z Preset bit – When this bit is set (1), a positive edge on Z preloads Counter X = Preset X, independent of Cal Enable. NOTE: If Z is configured to do Store and Preset (Reset), the Store will occur first.			
	Bit 05	Count Enable bit – When this is set (1), the incremental encoder is enabled.			
	Bits 06-08 (06-10)	Calibration Control bits – bits 06, 07 and 08			
		06	Enable bit – When this bit is set (1), the counter can be calibrated.		
		07	Direction bit – When this bit set (1), calibration is performed in a negative direction; when reset (0), calibration is performed in a positive direction.		
	Bits 09-10 (11-12)	08	Reset bit – Calibration is acknowledged and a new calibration is enabled on a positive edge on this bit.		
		10	09	Gate Control bits	
		0	0	No gate function on input G	
		0	1	Counting only if G is high (active)	
1		0	Counting only if G is low (inactive)		
1	1	The counter can be calibrated when G is high (active).			

Write Word	Bit	Definition			
Write Word 0 continued	Bits 11-12 (13-14)	12	11	Store Control bits - These bits will trigger a Store only if the channel Store status bit (L0 or L1) is cleared (0).	
		0	0	Save the counter value on the positive edge of Z (if Stored X = 0)	
		0	1	Save the counter value on the positive edge of G (if Stored X = 0)	
		1	0	Save the counter value on the negative edge of G (if Stored X = 0)	
		1	1	Save the counter value on the positive edge and negative edge of G (if Stored X = 0)	
	Bit 13 (15)	Rollover bit - When set (1), the counter counts up to the preset and then restarts at 0. If this bit is reset (0) (not rollover), the rollover preset value = FFFF (hex = 65535 (decimal)).			
	Bit 14 (16)	Store Reset bit - A positive edge on this bit resets Store X in Signals.			
Bit 15 (17)	Preset Reset bit - A positive edge on this bit resets Preset Reached in Signals.				
Write Word 1	Channel 1 Control Word - Control word for setting the function of counter 1.				
	Bits 00-02	02	01	00	Mode Selection bits
		0	0	0	Counting on positive (rising) edge of input signal A. (Up/down counting determined by B.)
		0	0	1	Quadrature encoder X1
		0	1	0	Quadrature encoder X2
		0	1	1	Quadrature encoder X4
		1	0	0	Counting up on the positive edge of input signal A, and down on positive edge of input signal B.
		1	0	1	No count function.
		1	1	0	No count function.
		1	1	1	No count function.
	Bit 03	Preset bit - A positive edge on this bit moves the value in Preset X to Counter X, independent of Preset Enable.			
Bit 04	Preset Enable bit - When this bit is set (1), a positive edge on Z preloads Counter X = Preset X, independent of Cal Enable.				
Bit 05	Count Enable bit - When this is set (1), the incremental encoder is counting.				

Write Word	Bit	Definition		
Word 1 continued	Bits 06-08 (06-10)	Calibration Control bits – bits 06, 07 and 08		
		06	Enable bit – When this bit is set (1), the counter can be calibrated.	
		07	Direction bit – When this bit set (1), calibration is performed in a negative direction; when reset (0), calibration is performed in a positive direction.	
		08	Reset bit – Calibration is acknowledged and a new calibration is enabled on a positive edge on this bit.	
	Bits 09-10	10	09	Gate Control bits
		0	0	No gate function on input G
		0	1	Counting only if G is high (active)
		1	0	Counting only if G is low (inactive)
		1	1	Calibration if G is high (active) and ???
	Bits 11-12 (13-14)	12	11	Store Control bits – These bits will trigger a Store only if the channel Store status bit (L0 or L1) is cleared (0).
		0	0	Save the counter value on the positive edge of Z (if Store X = 0)
		0	1	Save the counter value on the positive edge of G (if Store X = 0)
		1	0	Save the counter value on the negative edge of G (if Store X = 0)
		1	1	Save the counter value on the positive edge and negative edge of G (if Store X = 0)
	Bit 13	Rollover bit – When set (1), the counter counts up to the preset and then restarts at 0. If this bit is reset (0) (not rollover), the rollover preset value = FFFF (hex = 65535 (decimal)).		
Bit 14	Store Reset bit – A positive edge on this bit resets Store X in Signals.			
Bit 15	Store Reset bit – A positive edge on this bit resets Preset Reached in Signals.			
Word 2	Bits 00-15	Preset 0 – Value to load or compare with counter 0		
Word 3	Bits 00-15	Preset 1 – Value to load or compare with counter 1		
Word 4	Bit 00	Filter A0 enable – When this bit is set (1), and a counter 0 is in mode 000 (pulse counting), signal A0 is filtered by a digital low pass filter with selectable filter constant.		
	Bit 01	Filter A1 enable – When this bit is set (1), and a counter 1 is in mode 000 (pulse counting), signal A1 is filtered by a digital low pass filter with selectable filter constant.		
	Bit 02-07	Unused		
	Bits 08-09 (10-11)	09 (11)	08 (10)	Filter Constant bits – This constant is common to both counters.
		0	0	73.5kHz or minimum 0.007ms pulsewidth
		0	1	37.8kHz or minimum 0.013ms pulsewidth
		1	0	12.8kHz or minimum 0.04ms pulsewidth
	1	1	1.2kHz or minimum 0.4ms pulsewidth	
Bits 10-15 (12-17)	Reserved – set to 0			

Chapter Summary

In this chapter, you learned how to configure your module's features and enter your data.

How Communication Takes Place and I/O Image Table Mapping with the DeviceNet Adapter

What This Chapter Contains

In this chapter, we tell you about:

For information on	See page
About DeviceNetManager Software	5-1
Polled I/O Structure	5-1
Adapter Input Status Word	5-2
System Throughput	5-3
Mapping Data into the Image Table	5-3
Incremental Encoder Module (1794-ID2) Image Table Mapping	5-3
Block Transfer Read Word Assignments	5-4
Block Transfer Write Word Assignments	5-4
Word/Bit Descriptions	5-5
Defaults	5-9

About DeviceNetManager Software



DeviceNetManager software is a tool used to configure your FLEX I/O DeviceNet adapter and its related modules. This software tool can be connected to the adapter via the DeviceNet network.

You must understand how DeviceNetManager software works in order to add a device to the network. Refer to the DeviceNetManager Software User Manual, publication 1787-6.5.3.

Polled I/O Structure

Output data is received by the adapter in the order of the installed I/O modules. The Output data for Slot 0 is received first, followed by the Output data for Slot 1, and so on up to slot 7.

The first word of input data sent by the adapter is the Adapter Status Word. This is followed by the input data from each slot, in the order of the installed I/O modules. The Input data from Slot 0 is first after the status word, followed by Input data from Slot 2, and so on up to slot 7.

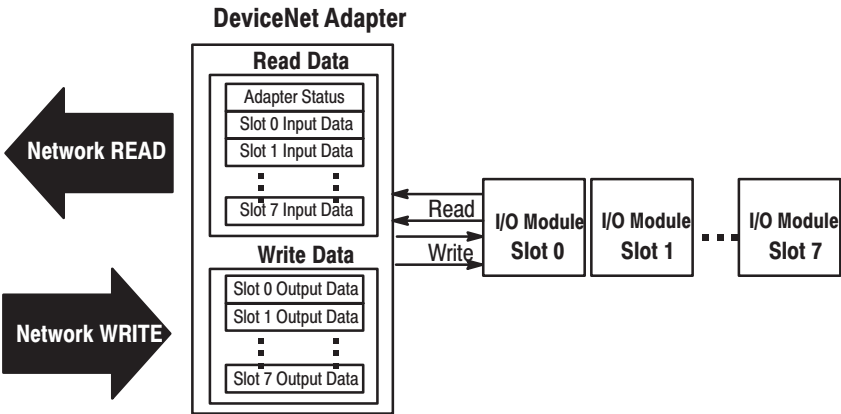

Adapter Input Status Word

The input status word consists of:

- I/O module fault bits – 1 status bit for each slot
- node address changed – 1 bit
- I/O status – 1 bit

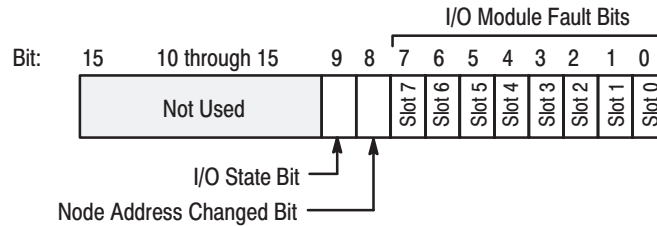

The adapter input status word bit descriptions are shown in the following table.

Bit Description	Bit	Explanation
I/O Module Fault	0	This bit is set (1) when an error is detected in slot position 0.
	1	This bit is set (1) when an error is detected in slot position 1.
	2	This bit is set (1) when an error is detected in slot position 2.
	3	This bit is set (1) when an error is detected in slot position 3.
	4	This bit is set (1) when an error is detected in slot position 4.
	5	This bit is set (1) when an error is detected in slot position 5.
	6	This bit is set (1) when an error is detected in slot position 6.
	7	This bit is set (1) when an error is detected in slot position 7.
Node Address Changed	8	This bit is set (1) when the node address switch setting has been changed since power up.
I/O State	9	Bit = 0 – idle Bit = 1 – run
	10 thru 15	Not used – sent as zeroes.

Possible causes for an **I/O Module Fault** are:

- transmission errors on the Flex I/O backplane
- a failed module
- a module removed from its terminal base
- incorrect module inserted in a slot position
- the slot is empty

The **node address changed** bit is set when the node address switch setting has been changed since power up. The new node address does not take effect until the adapter has been powered down and then powered back up.

System Throughput

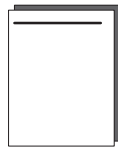

System throughput, from incremental encoder to backplane, is a function of:

- the configured minimum frequency sample time
- the number of channels actually configured for connection to a specific sensor (0 or 1)

You can set the minimum frequency time during module configuration. The selection influences the sample data rate, thus affecting system throughput.

The number of channels included in each input scan also affects system throughput.

Mapping Data into the Image Table

FLEX I/O incremental encoder module data table mapping is shown below.

Incremental Encoder Module (1794-ID2) Image Table Mapping

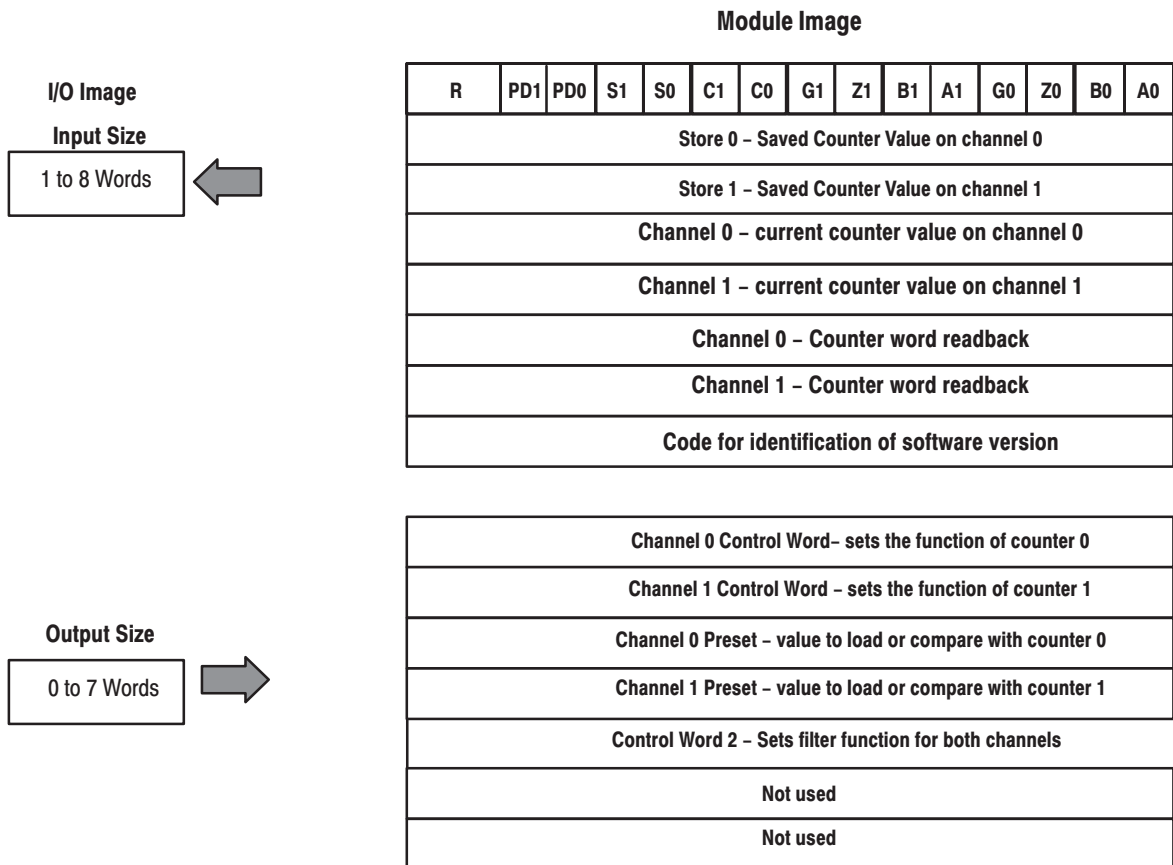

Block Transfer Read Word Assignments for the Incremental Encoder Module (1794-ID2)

(Octal Bit⇒)	17	16	15	14	13	12	11	10	07	06	05	04	03	02	01	00
Dec. Bit ⇒	15	14	13	12	11	10	09	08	07	06	05	04	03	02	01	00
Word↓	Read															
1	Not used	PR1	PR0	S1	S0	C1	C0	G1	Z1	B1	A1	G0	Z0	B0	A0	
2	Channel 0 – Stored counter value on channel 0															
3	Channel 1 – Stored counter value on channel 1															
4	Channel 0 – current counter value on channel 0															
5	Channel 1 – current counter value on channel 1															
6	Channel 0 – Counter word 0 readback															
7	Channel 1 – Counter word 1 readback															
8	Revision read – software version code															

Where: A0 = Status of input A, channel 0 – bit = 1 when input is on
 B0 = Status of input B, channel 0 – bit = 1 when input is on
 Z0 = Status of input Z, channel 0 – bit = 1 when input is on
 G0 = Status of input G, channel 0 – bit = 1 when input is on
 G1 = Status of input G, channel 1 – bit = 1 when input is on
 A1 = Status of input A, channel 1 – bit = 1 when input is on
 B1 = Status of input B, channel 1 – bit = 1 when input is on
 Z1 = Status of input Z, channel 1 – bit = 1 when input is on
 C0 = Cal 0 – when bit is set, counter 0 has been calibrated (reset by CalReset)
 C1 = Cal 1 – when bit is set, counter 1 has been calibrated (reset by CalReset)
 S0 = Stored 0 – when bit is set, counter 0 value has been saved in Store 0 (reset by StoreReset)
 S1 = Stored 1 – when bit is set, counter 1 value has been saved in Store 1 (reset by StoreReset)
 Once a Store occurs, L0 and L1 are on until cleared by StoreReset (counter word bit 14)
 PR0 = Preset 0 reached – when bit is set, counter 0 has reached value of preset (reset by PresetReset)
 PR1 = Preset 1 reached – when bit is set, counter 1 has reached value of preset (reset by PresetReset)

Block Transfer Write Word Assignments for the Incremental Encoder Module (1794-ID2)

(Octal Bit) ⇒	17	16	15	14	13	12	11	10	07	06	05	04	03	02	01	00
Dec. Bit ⇒	15	14	13	12	11	10	09	08	07	06	05	04	03	02	01	00
Word↓	Write															
1	Channel 0 Control Word – control word for setting the function of counter 0															
2	Channel 1 Control Word – control word for setting the function of counter 1															
3	Channel 0 Preset – value to load or compare with counter 0															
4	Channel 1 Preset – value to load or compare with counter 1															
5	Control Word 2 – control word for setting the filter function of both counters															
6-7	Not used															

Bit/Word Definitions for the incremental encoder Module (1794-ID2)

Word	Bit	Definition
Read Word 1	Bit 00	Status for input A (pulse transmitter 0) – This bit, when set, indicates a signal at A.
	Bit 01	Status for input B (pulse transmitter 0) – This bit, when set, indicates a signal at B.
	Bit 02	Status for input Z (pulse transmitter 0) – This bit, when set, indicates a signal at Z.
	Bit 03	Status for input G (pulse transmitter 0) – This bit, when set, indicates a signal at G.
	Bit 04	Status for input A (pulse transmitter 1) – This bit, when set, indicates a signal at A.
	Bit 05	Status for input B (pulse transmitter 1) – This bit, when set, indicates a signal at B.
	Bit 06	Status for input Z (pulse transmitter 1) – This bit, when set, indicates a signal at Z.
	Bit 07	Status for input G (pulse transmitter 1) – This bit, when set, indicates a signal at G.
	Bit 08 (10)	Cal 0 – This bit, when set (1), indicates that counter 0 has been calibrated. This bit is reset by CalReset.
	Bit 09 (11)	Cal 1 – This bit, when set (1), indicates that counter 1 has been calibrated. This bit is reset by CalReset.
	Bit 10 (12)	Store 0 – This bit, when set (1), indicates a counter value is saved in store 0. This bit is reset by StoreReset.
	Bit 11 (13)	Store 1 – This bit, when set (1), indicates a counter value is saved in store 1. This bit is reset by StoreReset.
	Bit 12 (14)	Preset Reached 0 (PR0) – When this bit is set (1), in all configuration modes, the counter 0 value equals the preset 0 value, either in a positive or negative direction. This bit is reset by PresetReset0 and can only be set again after at least 1 more pulse.
Bit 13 (15)	Preset Reached 1 (PR1) – When this bit is set (1), in all configuration modes, the counter 1 value equals the preset 1 value, either in a positive or negative direction. This bit is reset by PresetReset1 and can only be set again after at least 1 more pulse.	
	Bit 14–15 (16–17)	Not used – set to 0
Read Word 2	Bits 00–15 (00–17)	Store 0 – Saved counter value on channel 0
Read Word 3	Bits 00–15 (00–17)	Store 1 – Saved counter value on channel 1
Read Word 4	Bits 00–15 (00–17)	Channel 0 Current Counter Value – Current value in counter 0
Read Word 5	Bits 00–15 (00–17)	Channel 1 Current Counter Value – Current value in counter 1
Read Word 6	Bits 00–15 (00–17)	Counter 0 Readback – Counter word readback – last value written to write word 1
Read Word 7	Bits 00–15 (00–17)	Counter 1 Readback – Counter word readback – last value written to write word 2
Read Word 8	Bits 00–15 (00–17)	Revision Read – identification of latest software version code

Word	Bit	Definition			
Write Word 1	0-15 (0-17)	Control 0 – Control word for setting the function of counter 0.			
	Bits 00-02	02	01	00	Mode Selection bits
		0	0	0	Counting on positive (rising) edge of input signal A. (Up/dwn counting determined by B.)
		0	0	1	Quadrature encoder X1
		0	1	0	Quadrature encoder X2
		0	1	1	Quadrature encoder X4
		1	0	0	Counting up on the positive edge of input signal A, and down on positive edge of input signal B.
		1	0	1	No count function.
		1	1	0	No count function.
		1	1	1	No count function.
	Bit 03	Preset (Reset) bit – A positive edge on this bit moves the value in Preset X to Counter X, independent of Preset Enable. NOTE: To use Preset as Reset, use a count value of 0000 in the Preset value word.			
	Bit 04	Enable Z Preset bit – When this bit is set (1), a positive edge on Z preloads Counter X = Preset X, independent of Cal Enable. NOTE: If Z is configured to do Store and Preset (Reset), the Store will occur first.			
	Bit 05	Count Enable bit – When this is set (1), the incremental encoder is enabled.			
	Bits 06-08 (06-10)	Calibration Control bits – bits 06, 07 and 08			
		06	Enable bit – When this bit is set (1), the counter can be calibrated.		
		07	Direction bit – When this bit set (1), calibration is performed in a negative direction; when reset (0), calibration is performed in a positive direction.		
		08	Reset bit – Calibration is acknowledged and a new calibration is enabled on a positive edge on this bit.		
	Bits 09-10 (11-12)	Gate Control bits			
		10	09	No gate function on input G	
		0	0	Counting only if G is high (active)	
		1	0	Counting only if G is low (inactive)	
		1	1	The counter can be calibrated when G is high (active).	
	Bits 11-12 (13-14)	Store Control bits			
		12	11	Save the counter value on the positive edge of Z (if Stored X = 0)	
		0	0	Save the counter value on the positive edge of G (if Stored X = 0)	
		0	1	Save the counter value on the negative edge of G (if Stored X = 0)	
		1	0	Save the counter value on the positive edge and negative edge of G (if Stored X = 0)	
Bit 13 (15)	Rollover bit – When set (1), the counter counts up to the preset and then restarts at 0. If this bit is reset (0) (not rollover), the rollover preset value = FFFF (hex = 65535 (decimal)).				
Bit 14 (16)	Store Reset bit – A positive edge on this bit resets Stored X in Signals.				
Bit 15 (17)	Preset Reset bit – A positive edge on this bit resets Preset Detected in Signals.				

Word	Bit	Definition				
Write Word 2		Channel 1 Control Word – Control word for setting the function of counter 1.				
	Bits 00–02	Bit	02	01	00	Mode Selection bits
			0	0	0	Counting on positive (rising) edge of input signal A. (Up/dwn counting determined by B.)
			0	0	1	Quadrature encoder X1
			0	1	0	Quadrature encoder X2
			0	1	1	Quadrature encoder X4
			1	0	0	Counting up on the positive edge of input signal A, and down on positive edge of input signal B.
			1	0	1	No count function.
			1	1	0	No count function.
			1	1	1	No count function.
	Bit 03	Preset bit – A positive edge on this bit moves the value in Preset X to Counter X, independent of Preset Enable.				
	Bit 04	Preset Enable bit – When this bit is set (1), a positive edge on Z preloads Counter X = Preset X, independent of Cal Enable.				
	Bit 05	Count Enable bit – When this is set (1), the incremental encoder is counting.				
	Bits 06–08 (06–10)	Calibration Control bits – bits 06, 07 and 08				
		06	Enable bit – When this bit is set (1), the counter can be calibrated.			
		07	Direction bit – When this bit set (1), calibration is performed in a negative direction; when reset (0), calibration is performed in a positive direction.			
		08	Reset bit – Calibration is acknowledged and a new calibration is enabled on a positive edge on this bit.			
	Bits 09–10 (11–12)	10	09	Gate Control bits		
			0	0	No gate function on input G	
			0	1	Counting only if G is high (active)	
		1	0	Counting only if G is low (inactive)		
		1	1	Calibration if G is high (active) and ???		
Bits 11–12 (13–14)	12	11	Latch Control bits			
		0	0	Save the counter value on the positive edge of Z (if Stored X = 0)		
		0	1	Save the counter value on the positive edge of G (if Stored X = 0)		
		1	0	Save the counter value on the negative edge of G (if Stored X = 0)		
		1	1	Save the counter value on the positive edge and negative edge of G (if Stored X = 0)		
Bit 13 (15)	Rollover bit – When set (1), the counter counts up to the preset and then restarts at 0. If this bit is reset (0) (not rollover), the rollover preset value = FFFF (hex = 65535 (decimal).					
Bit 14 (16)	Store Reset bit – A positive edge on this bit resets Stored X in Signals.					
Bit 15 (17)	Store Reset bit – A positive edge on this bit resets Preset Reached in Signals.					
Write Word 3	Bits 00–15 (00–17)	Preset 0 – Value to load or compare with counter 0				
Write Word 4	Bits 00–15 (00–17)	Preset 1 – Value to load or compare with counter 1				

Word	Bit	Definition		
Word 5	Filter Selection			
	Bit 00	Filter A0 enable - When this bit is set (1), and a counter 0 is in mode 000 (pulse counting), signal A0 is filtered by a digital low pass filter with selectable filter constant.		
	Bit 01	Filter A1 enable - When this bit is set (1), and a counter 1 is in mode 000 (pulse counting), signal A1 is filtered by a digital low pass filter with selectable filter constant.		
	Bit 02-07	Unused		
	Bits 08-09 (10-11)	09 (11)	08 (1 0)	Filter Constant bits - This constant is common to both counters.
		0	0	73.5kHz or minimum 0.007ms pulsewidth
		0	1	37.8kHz or minimum 0.013ms pulsewidth
		1	0	12.8kHz or minimum 0.04ms pulsewidth
1	1	1.2kHz or minimum 0.4ms pulsewidth		
Write Words 6-7	Bits 00-15 (00-17)	Not used - set to 0.		

Defaults

Each I/O module has default values associated with it. At default, each module will generate inputs/status and expect outputs/configuration.

Module Defaults for:		Factory Defaults		Real Time Size	
Catalog Number	Description	Input Default	Output Default	Input Default	Output Default
1794-ID2	incremental encoder Module	9	7	4	0

Factory defaults are the values assigned by the adapter when you:

- first power up the system, and
- no previous stored settings have been applied.

For incremental encoder modules, the defaults reflect the actual number of input words/output words. For example, for the incremental encoder module, you have 9 input words, and 7 output words.

You can change the I/O data size for a module by reducing the number of words mapped into the adapter module, as shown in “real time sizes.”

Real time sizes are the settings that provide optimal real time data to the adapter module.

The incremental encoder modules have 15 words assigned to them. This is divided into input words/output words. You can reduce the I/O data size to fewer words to increase data transfer over the backplane.

For information on using DeviceNetManager software to configure your adapter, refer to the DeviceNetManager Software User Manual, publication 1787-6.5.3.



More

Input, Output and Configuration Files for Analog Modules when used with ControlNet

Chapter Objectives

In this chapter you will learn about:

- ControlNet Adapter
- I/O structure
- safe state data
- communication fault data
- idle state behavior
- input data behavior upon module removal

About the ControlNet Adapter

The FLEX I/O ControlNet adapters (cat. no. 1794-ACN15 and -ACNR15) interfaces up to 8 FLEX I/O modules and a ControlNet processor or scanner. The adapter can support ControlNet real-time data connections to individual modules or module groups. Each connection is independent of the others and can be from different processors or scanners.

Communication Over the FLEX I/O Backplane

One 1794-ACN15 and -ACNR15 ControlNet adapter can interface up to eight terminal base units with installed FLEX I/O modules, forming a FLEX I/O system of up to eight slots. The adapter communicates to other network system components (typically one or more controllers or scanners, and/or programming terminals) over the ControlNet network. The adapter communicates with its I/O modules over the backplane.

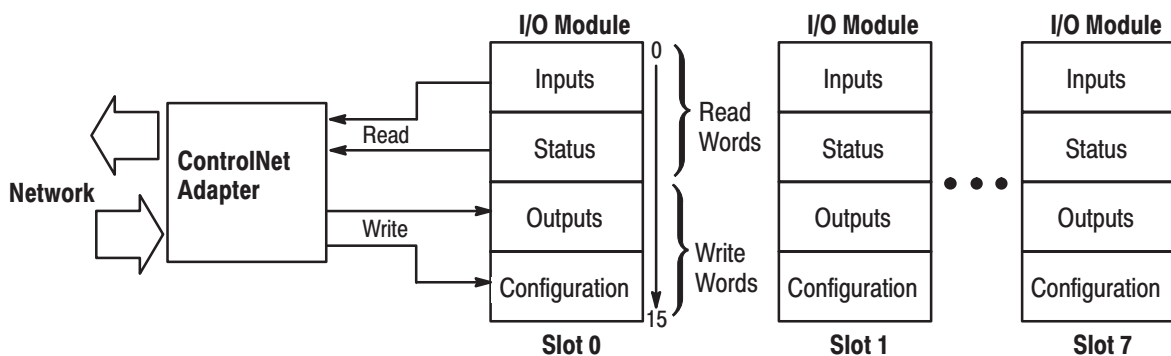

Data is exchanged scheduled (when mapped) or unscheduled (using CIO instructions).

Scheduled Data-Transfer

Scheduled data transfer:

- is continuous
- is asynchronous to the ladder-logic program scan
- occurs at the actual rate displayed in the Actual Packet Interval field on the programming software ControlNet I/O mapping (monitor) screen

Unscheduled Data-Transfer

Unscheduled operations include:

- unscheduled non-discrete I/O data transfers—through ControlNet I/O Transfer (CIO) instructions
- peer-to-peer messaging—through Message (MSG) instructions
- messaging from programming devices

Unscheduled messaging on a ControlNet network is non-deterministic. Your application and your configuration—number of nodes, application program, NUT, amount of scheduled bandwidth used, etc.—determine how much time there is for unscheduled messaging.

Module I/O Mapping

The I/O map for a module is divided into read words and write words. Read words consist of **input and status words**, and write words consist of **output and configuration words**. The number of read words or write words can be 0 or more. The length of each I/O module's read words and write words vary in size depending on module complexity. Each I/O module will support at least 1 input word or 1 output word. Status and configuration are optional, depending on the module.

For example, a 16 point discrete input module will have up to 2 read words and 1 write word.

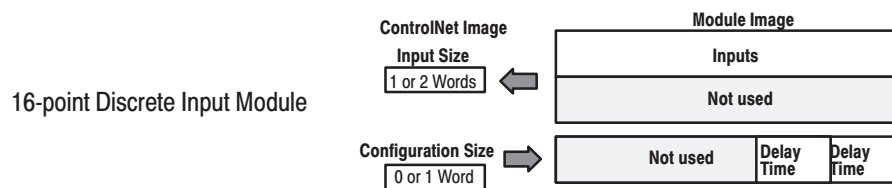

Check the I/O map for each module for the exact mapping.

I/O Structure

Output data is received by the adapter in the order of the installed I/O modules. The Output data for Slot 0 is received first, followed by the Output data for Slot 1, and so on up to slot 7.

The first word of input data sent by the adapter is the Adapter Status Word. This is followed by the input data from each slot, in the order of the installed I/O modules. The Input data from Slot 0 is first after the status word, followed by Input data from Slot 2, and so on up to slot 7.

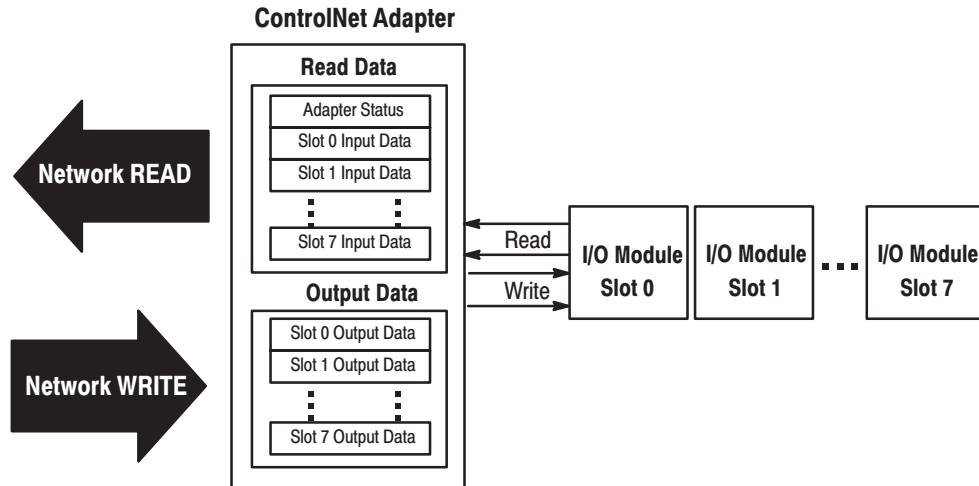

Adapter Input Status Word

The input status word consists of:

- I/O module fault bits – 1 status bit for each slot
- node address changed – 1 bit (created by PLC-5 controller)
- I/O status – 1 bit (created by PLC-5 controller)

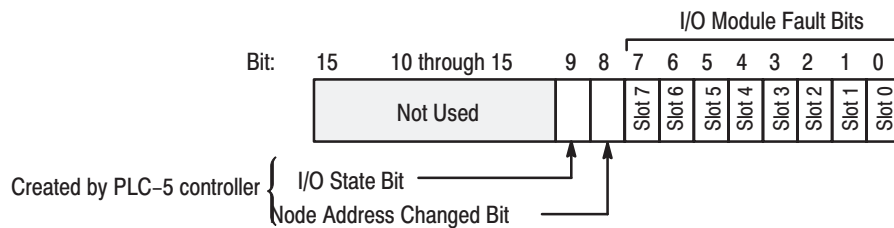

The adapter input status word bit descriptions are shown in the following table.

Bit Description	Bit	Explanation
I/O Module Fault	0	This bit is set (1) when an error is detected in slot position 0.
	1	This bit is set (1) when an error is detected in slot position 1.
	2	This bit is set (1) when an error is detected in slot position 2.
	3	This bit is set (1) when an error is detected in slot position 3.
	4	This bit is set (1) when an error is detected in slot position 4.
	5	This bit is set (1) when an error is detected in slot position 5.
	6	This bit is set (1) when an error is detected in slot position 6.
	7	This bit is set (1) when an error is detected in slot position 7.
Node Address Changed (Created by PLC-5 controller.)	8	This bit is set (1) when the node address switch setting has been changed since power up.
I/O State (Created by PLC-5 controller.)	9	Bit = 0 - idle Bit = 1 - run
	10 thru 15	Not used - set to 0.

Possible causes for an **I/O Module Fault** are:

- transmission errors on the FLEX I/O backplane
- a failed module
- a module removed from its terminal base
- incorrect module inserted in a slot position
- the slot is empty
- the slot contains a non-discrete module

Safe State Data

The ControlNet adapter provides storage for alternate module output data during communication faults or processor idle state. This “safe state data” assures that a known output will be applied to the output devices to maintain a previously designated safe operating condition during the previously mentioned failure modes. The processor or scanner software must include the means to specify this safe state data for each module. If applicable, this data is sent in the configuration block (see Image Table Mapping later in this chapter).

Device Actions

Device actions include:

- communication fault behavior
- idle state behavior
- input data behavior upon module removal

Communication Fault Behavior

You can configure the adapter response to a communication fault for each I/O module in its system. Upon detection of a communication fault, the adapter can:

- leave the module output data in its last state (hold last state)
- reset the module output data to zero (reset)
- apply safe state data to the module output

Idle State Behavior

The ControlNet adapter can detect the state of the controlling processor or scanner. Only 2 states can be detected: run mode, or program mode (idle).

When run mode is detected, the adapter copies the output data received from the processor to the corresponding module output. When program mode is detected, the adapter can be configured to:

- leave the module output data in its last state (hold last state)
- reset the module output data to zero (reset)
- apply safe state data to the module output

Input Data Behavior upon Module Removal

I/O module input data sent by the adapter upon module removal is configurable. The adapter can:

- reset the module output data to zero (reset)
- leave the module output data in the last state before module removal (hold last state)

Incremental Encoder Module (1794-ID2) Image Table Mapping

Module Image

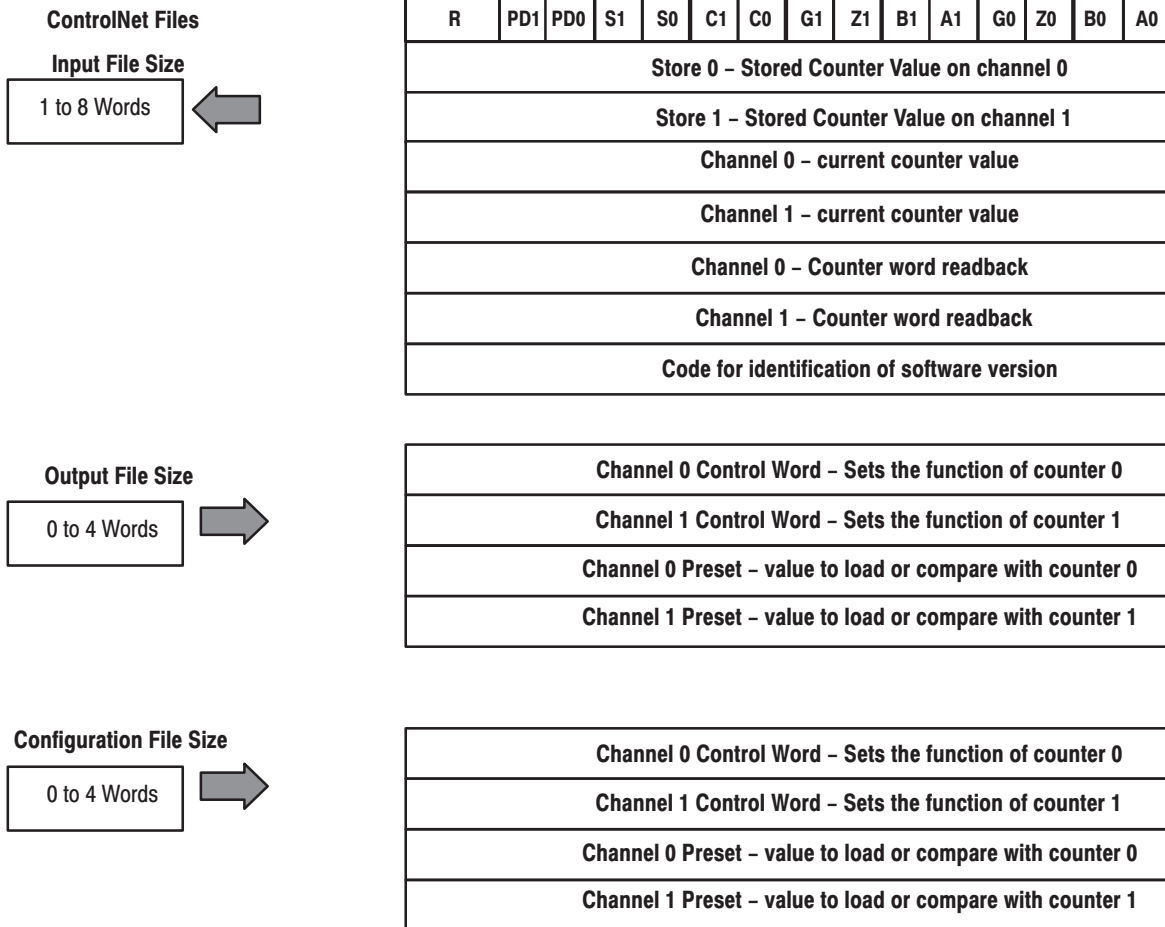

Bit/Word Definitions for Block Transfer Read Words for the Pulse Counter Module

Input Word	Bit	Definition
Input Word 0	Bit 00	Status for input A (pulse transmitter 0) - This bit, when set, indicates a signal at A.
	Bit 01	Status for input B (pulse transmitter 0) - This bit, when set, indicates a signal at B.
	Bit 02	Status for input Z (pulse transmitter 0) - This bit, when set, indicates a signal at Z.
	Bit 03	Status for input G (pulse transmitter 0) - This bit, when set, indicates a signal at G.
	Bit 04	Status for input A (pulse transmitter 1) - This bit, when set, indicates a signal at A.
	Bit 05	Status for input B (pulse transmitter 1) - This bit, when set, indicates a signal at B.

Input Word	Bit	Definition
Word 0 continued	Bit 06	Status for input Z (pulse transmitter 1) – This bit, when set, indicates a signal at Z.
	Bit 07	Status for input G (pulse transmitter 1) – This bit, when set, indicates a signal at G.
	Bit 08 (10)	Cal 0 – This bit, when set (1), indicates that counter 0 has been calibrated. This bit is reset by CalReset.
	Bit 09 (11)	Cal 1 – This bit, when set (1), indicates that counter 1 has been calibrated. This bit is reset by CalReset.
	Bit 10 (12)	Store 0 – This bit, when set (1), indicates a counter value is saved in store 0. This bit is reset by StoreReset.
	Bit 11 (13)	Store 1 – This bit, when set (1), indicates a counter value is saved in store 1. This bit is reset by StoreReset.
	Bit 12 (14)	Preset Reached 0 (PR0) – When this bit is set (1), in all configuration modes, the counter 0 value equals the preset 0 value, either in a positive or negative direction. This bit is reset by PresetReset0 and can only be set again after at least 1 more pulse.
	Bit 13 (15)	Preset Reached 1 (PR1) – When this bit is set (1), in all configuration modes, the counter 1 value equals the preset 1 value, either in a positive or negative direction. This bit is reset by PresetReset1 and can only be set again after at least 1 more pulse.
	Bit 14-15 (16-17)	Not used – set to 0
Word 1	Bits 00-15 (00-17)	Store 0 – Saved counter value on channel 0
Word 2	Bits 00-15 (00-17)	Store 1 – Saved counter value on channel 1
Word 3	Bits 00-15 (00-17)	Channel 0 Current Counter Value – Current value in counter 0
Word 4	Bits 00-15 (00-17)	Channel 1 Current Counter Value – Current value in counter 1
Word 5	Bits 00-15 (00-17)	Channel 0 Readback – Counter word readback)
Word 6	Bits 00-15 (00-17)	Channel 0 Readback – Counter word readback)
Word 7	Bits 00-15 (00-17)	Software identification

Output Word	Bit	Definition		
Word 0		Channel 0 Control Word – Control word for setting the function of counter 0.		
Bits 00–02	02	01	00	Mode Selection bits
	0	0	0	Counting on positive (rising) edge of input signal A. (Up/dwn counting determined by B.)
	0	0	1	Quadrature encoder X1
	0	1	0	Quadrature encoder X2
	0	1	1	Quadrature encoder X4
	1	0	0	Counting up on the positive edge of input signal A, and down on positive edge of input signal B.
	1	0	1	No count function.
	1	1	0	No count function.
1	1	1	No count function.	
Bit 03	Preset (Reset) bit – A positive edge on this bit moves the value in Preset X to Counter X, independent of Preset Enable. NOTE: To use Preset as Reset, use a count value of 0000 in the Preset value word.			
Bit 04	Enable Z Preset bit – When this bit is set (1), a positive edge on Z preloads Counter X = Preset X, independent of Cal Enable. NOTE: If Z is configured to do Store and Preset (Reset), the Store will occur first.			
Bit 05	Count Enable bit – When this is set (1), the pulse counter is enabled.			
Bits 06–08 (06–10)	Calibration Control bits – bits 06, 07 and 08			
	06	Enable bit – When this bit is set (1), the counter can be calibrated.		
	07	Direction bit – When this bit set (1), calibration is performed in a negative direction; when reset (0), calibration is performed in a positive direction.		
Bits 09–10 (11–12)	08	Reset bit – Calibration is acknowledged and a new calibration is enabled on a positive edge on this bit.		
	10	09	Gate Control bits	
	0	0	No gate function on input G	
	0	1	Counting only if G is high (active)	
1	0	Counting only if G is low (inactive)		
1	1	The counter can be calibrated when G is high (active).		
Bits 11–12 (13–14)	12	11	Store Control bits – These bits will trigger a Store only if the channel Store status bit (L0 or L1) is cleared (0).	
	0	0	Save the counter value on the positive edge of Z (if Stored X = 0)	
	0	1	Save the counter value on the positive edge of G (if Stored X = 0)	
	1	0	Save the counter value on the negative edge of G (if Stored X = 0)	
1	1	Save the counter value on the positive edge and negative edge of G (if Stored X = 0)		
Bit 13 (15)	Rollover bit – When set (1), the counter counts up to the preset and then restarts at 0. If this bit is reset (0) (not rollover), the rollover preset value = FFFF (hex = 65535 (decimal)).			
Bit 14 (16)	Store Reset bit – A positive edge on this bit resets Store X in Signals.			
Bit 15 (17)	Preset Reset bit – A positive edge on this bit resets Preset Reached in Signals.			

Output Word	Bit	Definition			
Word 1	Channel 1 Control Word – Control word for setting the function of counter 1.				
	Bits 00–02	02	01	00	Mode Selection bits
		0	0	0	Counting on positive (rising) edge of input signal A. (Up/dwn counting determined by B.)
		0	0	1	Quadrature encoder X1
		0	1	0	Quadrature encoder X2
		0	1	1	Quadrature encoder X4
		1	0	0	Counting up on the positive edge of input signal A, and down on positive edge of input signal B.
		1	0	1	No count function.
		1	1	0	No count function.
		1	1	1	No count function.
	Bit 03	Preset bit – A positive edge on this bit moves the value in Preset X to Counter X, independent of Preset Enable.			
	Bit 04	Preset Enable bit – When this bit is set (1), a positive edge on Z preloads Counter X = Preset X, independent of Cal Enable.			
	Bit 05	Count Enable bit – When this is set (1), the pulse counter is counting.			
	Bits 06–08 (06–10)	Calibration Control bits – bits 06, 07 and 08			
		06	Enable bit – When this bit is set (1), the counter can be calibrated.		
		07	Direction bit – When this bit set (1), calibration is performed in a negative direction; when reset (0), calibration is performed in a positive direction.		
		08	Reset bit – Calibration is acknowledged and a new calibration is enabled on a positive edge on this bit.		
	Bits 09–10	10	09	Gate Control bits	
		0	0	No gate function on input G	
		0	1	Counting only if G is high (active)	
		1	0	Counting only if G is low (inactive)	
		1	1	Calibration if G is high (active) and ???	
	Bits 11–12 (13–14)	12	11	Store Control bits – These bits will trigger a Store only if the channel Store status bit (L0 or L1) is cleared (0).	
		0	0	Save the counter value on the positive edge of Z (if Store X = 0)	
		0	1	Save the counter value on the positive edge of G (if Store X = 0)	
		1	0	Save the counter value on the negative edge of G (if Store X = 0)	
1		1	Save the counter value on the positive edge and negative edge of G (if Store X = 0)		
Bit 13	Rollover bit – When set (1), the counter counts up to the preset and then restarts at 0. If this bit is reset (0) (not rollover), the rollover preset value = FFFF (hex = 65535 (decimal)).				
Bit 14	Store Reset bit – A positive edge on this bit resets Store X in Signals.				
Bit 15	Store Reset bit – A positive edge on this bit resets Preset Detected in Signals.				
Word 2	Bits 00–15	Preset 0 – Value to load or compare with counter 0			
Word 3	Bits 00–15	Preset 1 – Value to load or compare with counter 1			

Configuration Word	Bit	Definition		
Word 0	Channel 0 Control Word – Control word for setting the function of counter 0.			
Bits 00–02	02	01	00	Mode Selection bits
	0	0	0	Counting on positive (rising) edge of input signal A. (Up/down counting determined by B.)
	0	0	1	Quadrature encoder X1
	0	1	0	Quadrature encoder X2
	0	1	1	Quadrature encoder X4
	1	0	0	Counting up on the positive edge of input signal A, and down on positive edge of input signal B.
	1	0	1	No count function.
	1	1	0	No count function.
	1	1	1	No count function.
Bit 03	Preset (Reset) bit – A positive edge on this bit moves the value in Preset X to Counter X, independent of Preset Enable. NOTE: To use Preset as Reset, use a count value of 0000 in the Preset value word.			
Bit 04	Enable Z Preset bit – When this bit is set (1), a positive edge on Z preloads Counter X = Preset X, independent of Cal Enable. NOTE: If Z is configured to do Store and Preset (Reset), the Store will occur first.			
Bit 05	Count Enable bit – When this is set (1), the pulse counter is enabled.			
Bits 06–08 (06–10)	Calibration Control bits – bits 06, 07 and 08			
	06	Enable bit – When this bit is set (1), the counter can be calibrated.		
	07	Direction bit – When this bit set (1), calibration is performed in a negative direction; when reset (0), calibration is performed in a positive direction.		
	08	Reset bit – Calibration is acknowledged and a new calibration is enabled on a positive edge on this bit.		
Bits 09–10 (11–12)	10	09	Gate Control bits	
	0	0	No gate function on input G	
	0	1	Counting only if G is high (active)	
	1	0	Counting only if G is low (inactive)	
	1	1	The counter can be calibrated when G is high (active).	
Bits 11–12 (13–14)	12	11	Store Control bits – These bits will trigger a Store only if the channel Store status bit (L0 or L1) is cleared (0).	
	0	0	Save the counter value on the positive edge of Z (if Latched X = 0)	
	0	1	Save the counter value on the positive edge of G (if Latched X = 0)	
	1	0	Save the counter value on the negative edge of G (if Latched X = 0)	
	1	1	Save the counter value on the positive edge and negative edge of G (if Latched X = 0)	
Bit 13 (15)	Rollover bit – When set (1), the counter counts up to the preset and then restarts at 0. If this bit is reset (0) (not rollover), the rollover preset value = FFFF (hex = 65535 (decimal)).			
Bit 14 (16)	Store Reset bit – A positive edge on this bit resets Store X in Signals.			
Bit 15 (17)	Preset Reset bit – A positive edge on this bit resets Preset Detected in Signals.			

Configuration Word	Bit	Definition				
Word 1	Channel 1 Control Word – Control word for setting the function of counter 1.					
	Bits 00–02	Bit	02	01	00	Mode Selection bits
			0	0	0	Counting on positive (rising) edge of input signal A. (Up/dwn counting determined by B.)
			0	0	1	Quadrature encoder X1
			0	1	0	Quadrature encoder X2
			0	1	1	Quadrature encoder X4
			1	0	0	Counting up on the positive edge of input signal A, and down on positive edge of input signal B.
			1	0	1	No count function.
			1	1	0	No count function.
			1	1	1	No count function.
	Bit 03	Preset bit – A positive edge on this bit moves the value in Preset X to Counter X, independent of Preset Enable.				
	Bit 04	Preset Enable bit – When this bit is set (1), a positive edge on Z preloads Counter X = Preset X, independent of Cal Enable.				
	Bit 05	Count Enable bit – When this is set (1), the pulse counter is counting.				
	Bits 06–08 (06–10)	Calibration Control bits – bits 06, 07 and 08				
		06	Enable bit – When this bit is set (1), the counter can be calibrated.			
		07	Direction bit – When this bit set (1), calibration is performed in a negative direction; when reset (0), calibration is performed in a positive direction.			
		08	Reset bit – Calibration is acknowledged and a new calibration is enabled on a positive edge on this bit.			
	Bits 09–10	10	09	Gate Control bits		
			0	0	No gate function on input G	
			0	1	Counting only if G is high (active)	
			1	0	Counting only if G is low (inactive)	
			1	1	Calibration if G is high (active) and ???	
	Bits 11–12 (13–14)	12	11	Store Control bits – These bits will trigger a Store only if the channel Store status bit (L0 or L1) is cleared (0).		
		0	0	Save the counter value on the positive edge of Z (if Store X = 0)		
		0	1	Save the counter value on the positive edge of G (if Store X = 0)		
		1	0	Save the counter value on the negative edge of G (if Store X = 0)		
		1	1	Save the counter value on the positive edge and negative edge of G (if Store X = 0)		
Bit 13	Rollover bit – When set (1), the counter counts up to the preset and then restarts at 0. If this bit is reset (0) (not rollover), the rollover preset value = FFFF (hex = 65535 (decimal)).					
Bit 14	Store Reset bit – A positive edge on this bit resets Store X in Signals.					
Bit 15	Store Reset bit – A positive edge on this bit resets Preset Detected in Signals.					
Word 2	Bits 00–15	Preset 0 – Value to load or compare with counter 0				
Word 3	Bits 00–15	Preset 1 – Value to load or compare with counter 1				

Calibrating Your Incremental Encoder Module

Chapter Objective

In this chapter, we tell you how to set up your system to calibrate the incremental encoder.

Calibrating Your Module

The incremental encoder module **does not require calibration**. However, you must synchronize the module with the process you are monitoring.

You must have your incremental encoder module installed in an operating FLEX I/O system in order to complete synchronization.

Process calibration of the counter synchronizes the control system with the machinery where the incremental encoder is mounted. The counter is set to a preset value when a reference pulse is received. Use input Z to activate calibration. The input to Z can be a zero pulse integrated with an incremental encoder. Or input Z can come from another transmitter independent of the pulse transmitter. Calibration is performed at the first positive edge of input signal Z and is independent of the signal duration.

Calibration is enabled if *CalEnable* = 1 or if *GateControl* = 3 and G input = 1. The counter direction must coincide with *CalDirection* and *Calibrated* must be = 0 (acknowledged by a positive edge on *CalReset*). When calibration is activated, the counter is given the value in *PresetValue* and *Calibrated* will be set. The counter value can be saved in *StoreValue* if *StoreControl* = 0 and *Stored* = 0. Note that the condition for the latch function is not dependent on the direction and therefore does not automatically occur on that edge of Z which activates calibration.

Calibration Method 1

Calibration is enabled by the flag *CalEnable*, which is enabled by the control system. The preset value is copied to the counter register at a positive edge on input Z. The old counter register value is saved in the store register for evaluation.

Calibration direction is determined by *CalDirection* (0 = positive direction, 1 = negative direction).

Reset *Calibrated*, *Stored* and *PresetReached* after calibration with *CalReset*, *StoreReset* and *PresetReset*.

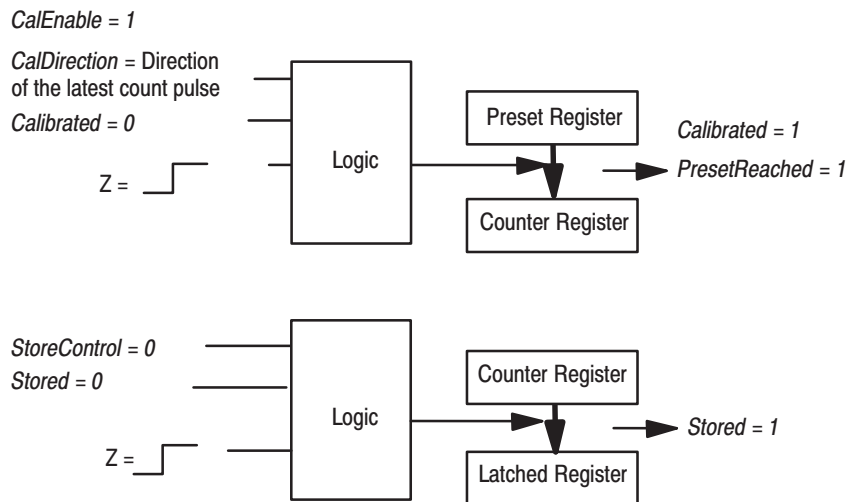

Calibration Method 2

Calibration is enabled by input G if $GateControl = 3$ and $Calibrated = 0$. The preset value is copied to the counter register at a positive edge on input signal Z. The old counter register value is saved in the store register for evaluation.

Calibration direction is determined by $CalDirection$ (0 = positive direction, 1 = negative direction).

Reset $Calibrated$, $Stored$ and $PresetReached$ after calibration with $CalReset$, $StoreReset$ and $PresetReset$.

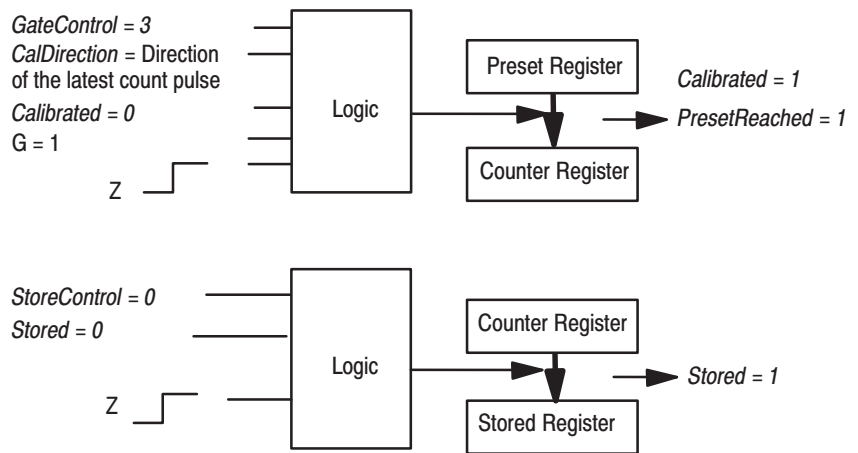

Troubleshoot the Incremental Encoder Module

What This Chapter Contains

Use this chapter to troubleshoot the incremental encoder module by interpreting the indicators.

Status Indicators

The module contains indicators for each of the following:

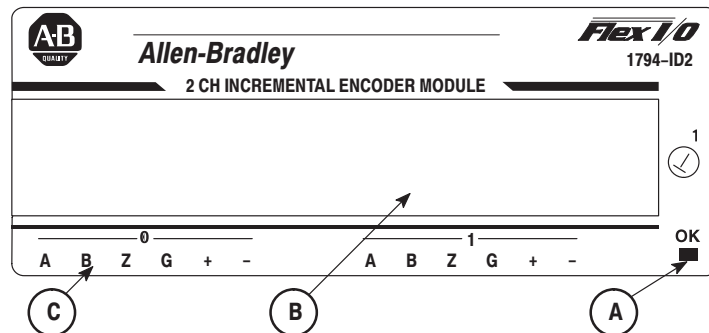

A = Power/status indicator – indicates power applied to module and status of module.

B = Insertable label for writing individual I/O assignments.

C = Status Indicators –

A = Status of input A

B = Status of input B

Z = Status of input Z

G = Status of input G

+ = Positive count detected

- = Negative count detected

Indicator	Indication	Explanation
A	Yellow	Input A active
	Off	Input A not active
B	Yellow	Input B active
	Off	Input B not active
Z	Yellow	Input Z active
	Off	Input Z not active
G	Yellow	Input G active
	Off	Input G not active
+	Yellow	On when a positive pulse is detected; turns off on negative pulse.
-	Yellow	On when a negative pulse is detected; turns off on positive pulse.
OK	Red	Red during initialization after power turned on
	Green	Green when initialization is completed

When an input indicator (yellow) is lighted, it indicates that a valid signal (active high or active low) is present at one of the Input terminals.

What's Next

To find out more about the ID2 module:

See appendix A



For specifications on the ID2 module

Specifications

Specifications - 1794-ID2 2 Input Incremental Encoder Module					
Input Specifications					
Number of Counters	2				
Number of Inputs per Counter	4 inputs (A, B, Z, G)				
Input Pulse Width (minimum)	Each signal condition must be stable for at least 2 μ s to be recognized.				
Counting Frequency	100KHz maximum.				
Input Range	<table style="width: 100%; border: none;"> <tr> <td style="width: 150px;">Input ON</td> <td>Maximum 26.4V dc (24V dc +10%) Minimum 6V dc</td> </tr> <tr> <td>Input OFF</td> <td>Maximum 3V dc Minimum -26.4V dc</td> </tr> </table>	Input ON	Maximum 26.4V dc (24V dc +10%) Minimum 6V dc	Input OFF	Maximum 3V dc Minimum -26.4V dc
Input ON	Maximum 26.4V dc (24V dc +10%) Minimum 6V dc				
Input OFF	Maximum 3V dc Minimum -26.4V dc				
Input Current (typical)	<table style="width: 100%; border: none;"> <tr> <td>3mA @ 6V dc</td> </tr> <tr> <td>9mA @ 12V dc</td> </tr> <tr> <td>15mA @ 24V dc</td> </tr> </table>	3mA @ 6V dc	9mA @ 12V dc	15mA @ 24V dc	
3mA @ 6V dc					
9mA @ 12V dc					
15mA @ 24V dc					
General Specifications					
Module Location	Cat. No. 1794-TB3, -TB3S, -TBN, -TBNF Terminal Base				
Isolation Voltage	500V dc				
Flexbus Current	0mA @ 5V dc				
Power Supply	12-24V dc (+10%)				
Current consumption from external power supply	<table style="width: 100%; border: none;"> <tr> <td>150mA @ 12V dc</td> </tr> <tr> <td>75mA @ 24V dc</td> </tr> </table>	150mA @ 12V dc	75mA @ 24V dc		
150mA @ 12V dc					
75mA @ 24V dc					
Power Dissipation	5W maximum @ 26.4V dc				
Thermal Dissipation	Maximum 17.1 BTU/hr @ 26.4V dc				
Indicators (field side driven, logic side indication)	<table style="width: 100%; border: none;"> <tr> <td>1 green/red power/status indicator</td> </tr> <tr> <td>12 yellow status indicators - logic side</td> </tr> </table>	1 green/red power/status indicator	12 yellow status indicators - logic side		
1 green/red power/status indicator					
12 yellow status indicators - logic side					
Keyswitch Position	1				
Dimensions Inches (Millimeters)	<table style="width: 100%; border: none;"> <tr> <td>1.8H x 3.7W x 2.1D</td> </tr> <tr> <td>(45.7 x 94.0 x 53.3)</td> </tr> </table>	1.8H x 3.7W x 2.1D	(45.7 x 94.0 x 53.3)		
1.8H x 3.7W x 2.1D					
(45.7 x 94.0 x 53.3)					
Specifications continued on next page.					

Specifications - 1794-ID2 2 Input Incremental Encoder Module

Environmental Conditions	
Operational Temperature	0 to 55°C (32 to 131°F) Note: Do not connect maximum input voltage simultaneously to all inputs if the module ambient temperature is expected to exceed 40°C.
Storage Temperature	-25 to 70°C (-13 to 158°F)
Relative Humidity	5 to 90% noncondensing (operating) 5 to 80% noncondensing (nonoperating)
Shock	Operating 30 g peak acceleration, 11(+1)ms pulse width Nonoperating 50 g peak acceleration, 11(±1)ms pulse width
Vibration	Tested 2 g @ 10-500Hz per IEC 68-2-6
Input Conductors	
Wire	Belden 8761
Category	2 ¹
Length (max)	1000ft (304.8m)
Agency Certification (when product is marked)	<ul style="list-style-type: none"> • CUL certified • CUL listed - Class I, Division 2 Groups A, B, C, D • UL listed • CE marked for all applicable directives
Installation Instruction	Publication 1794-5.63
<small>1 Use this conductor category information for planning conductor routing . Refer to publication 1770-4.1, "Industrial Automation Wiring and Grounding Guidelines for Noise Immunity."</small>	

Numbers

1794-ID2, troubleshoot, 8-1

A

adapter input status word, 5-1, 6-3

applications, typical, 1-3

B

bit/word definitions, block transfer write, 4-5

bit/Word descriptions, 4-5

bit/word descriptions, block transfer read,
4-3, 5-5, 6-6

block transfer

read, 1-2

write, 1-2

block transfer programming

PLC-2 family processor, 3-2

PLC-5 family processor, 3-2

block transfer read, 3-1, 4-2

word assignments, 4-3, 5-4

block transfer write, 3-1

bit/word assignments, 4-5

word assignments, 4-5, 5-4

C

CIOs. *See* ControlNet I/O Transfer
instructions

communication, block transfers, 3-1

compatible terminal bases, 2-9

configurable features, 4-1

connecting wiring, 2-9

considerations, pre-installation, 2-1

ControlNet I/O

unscheduled non-discrete I/O data
transfer, 6-2

unscheduled operations

ladder-rung messages, 6-2

messaging from programming devices,
6-2

peer-to-peer messaging, 6-2

ControlNet I/O Transfer (CIO) instructions,
6-2

current draw, through base units, 2-2

D

daisy-chaining wiring, 2-3

default values, 5-8

DeviceNetManager, software, 5-1

DIN rail mounting, 2-4

E

European Union Directive compliance, 2-1

F

frequency input module

how it works, 1-2

input capabilities, 1-3

typical applications, 1-3

using, 1-1

I

I/O, ControlNet

unscheduled non-discrete I/O data
transfer, 6-2

unscheduled operations

messaging from programming devices,
6-2

non-discrete I/O data transfer, 6-2

peer-to-peer messaging, 6-2

I/O module fault, 5-2

indicators

states, 2-14

status, 2-14

troubleshooting, 8-1

input mapping, 4-2, 5-3, 6-6

input status word, 5-2, 6-3

installation, module, 2-7

K

keyswitch positions, 2-7

L

ladder-rung messaging, 6-2

M

mapping

1794-ID2, 4-2, 5-3, 6-6

example, 6-2

explanation, 6-2

Message instructions, 6-2

module fault, 5-2

module installation, 2-7

mounting, on terminal base, 2-7

mounting kit, cat. no. 1794-NM1, 2-6

MSGs. *See* Message instructions

O

optimal defaults, 5-8

P

panel/wall mounting, 2-6

PLC-2 family processor, block transfer programming, 3-2

PLC-5 family processor, block transfer programming, 3-2

polled I/O, structure, 5-1, 6-3

power defaults, 5-8

R

removing and replacing, under power (RIUP), 2-8

S

sample program, PLC-5, 3-2

software, DeviceNetManager, 5-1

status indicators, 2-14

system throughput, 5-3

T

terminal bases, compatible, 2-9

troubleshooting, 8-1

U

unscheduled non-discrete I/O data transfer, 6-2

W

wall/panel mounting, 2-6

wiring, methods of, 2-3

wiring connections, 2-9
1794-ID2, 2-12

word assignments

block transfer read, 4-3, 5-4

block transfer write, 4-5, 5-4



Allen-Bradley Publication Problem Report

If you find a problem with our documentation, please complete and return this form.

Pub. Name 2 Channel Incremental Encoder Module User Manual

Cat. No. 1794-ID2/B Pub. No. 1794-UM015B-EN-P Pub. Date May 2001 Part No. _____

Check Problem(s) Type:	Describe Problem(s):	Internal Use Only
<input type="checkbox"/> Technical Accuracy	<input type="checkbox"/> text <input type="checkbox"/> illustration	
<input type="checkbox"/> Completeness What information is missing?	<input type="checkbox"/> procedure/step <input type="checkbox"/> illustration <input type="checkbox"/> definition <input type="checkbox"/> example <input type="checkbox"/> guideline <input type="checkbox"/> feature <input type="checkbox"/> explanation <input type="checkbox"/> other	<input type="checkbox"/> info in manual (accessibility) <input type="checkbox"/> info not in manual
<input type="checkbox"/> Clarity What is unclear?		
<input type="checkbox"/> Sequence What is not in the right order?		
<input type="checkbox"/> Other Comments Use back for more comments.		

Your Name _____ Location/Phone _____

Return to: Technical Communications, Rockwell Automation, 1 Allen-Bradley Drive, Mayfield Hts., OH 44124-6118
Phone: (440)646-3176
FAX: (440)646-3525

PLEASE FASTEN HERE (DO NOT STAPLE)

Other Comments

PLEASE FOLD HERE



NO POSTAGE
NECESSARY
IF MAILED
IN THE
UNITED STATES

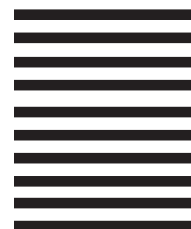

PLEASE REMOVE

BUSINESS REPLY MAIL

FIRST-CLASS MAIL PERMIT NO. 18235 CLEVELAND OH

POSTAGE WILL BE PAID BY THE ADDRESSEE



Allen-Bradley

1 ALLEN BRADLEY DR
MAYFIELD HEIGHTS OH 44124-9705



Support Services

At Allen-Bradley, customer service means experienced representatives at Customer Support Centers in key cities throughout the world for sales service and support. Our value-added services include:

Technical Support

- SupportPlus programs
- telephone support and 24-hour emergency hotline
- software and documentation updates
- technical subscription services

Engineering and Field Services

- application engineering assistance
- integration and start-up assistance
- field service
- maintenance support

Technical Training

- lecture and lab courses
- self-paced computer and video-based training
- job aids and workstations
- training needs analysis

Repair and Exchange Services

- your only “authorized” source
- current revisions and enhancements
- worldwide exchange inventory
- local support



Allen-Bradley, a Rockwell Automation Business, has been helping its customers improve productivity and quality for more than 90 years. We design, manufacture and support a broad range of automation products worldwide. They include logic processors, power and motion control devices, operator interfaces, sensors and a variety of software. Rockwell is one of the world's leading technology companies.



Worldwide representation.

Argentina • Australia • Austria • Bahrain • Belgium • Brazil • Bulgaria • Canada • Chile • China, PRC • Colombia • Costa Rica • Croatia • Cyprus • Czech Republic • Denmark • Ecuador • Egypt • El Salvador • Finland • France • Germany • Greece • Guatemala • Honduras • Hong Kong • Hungary • Iceland • India • Indonesia • Ireland • Israel • Italy • Jamaica • Japan • Jordan • Korea • Kuwait • Lebanon • Malaysia • Mexico • Netherlands • New Zealand • Norway • Pakistan • Peru • Philippines • Poland • Portugal • Puerto Rico • Qatar • Romania • Russia-CIS • Saudi Arabia • Singapore • Slovakia • Slovenia • South Africa, Republic • Spain • Sweden • Switzerland • Taiwan • Thailand • Turkey • United Arab Emirates • United Kingdom • United States • Uruguay • Venezuela • Yugoslavia

Allen-Bradley Headquarters, 1201 South Second Street, Milwaukee, WI 53204 USA, Tel: (1) 414 382-2000 Fax: (1) 414 382-4444