

PowerFlex 700 AC Drives – Series A, Frames 0...6

Standard Control Firmware 3.001 and Below

Vector Control Firmware 3.002 and Below



Important User Information

Read this document and the documents listed in the additional resources section about installation, configuration, and operation of this equipment before you install, configure, operate, or maintain this product. Users are required to familiarize themselves with installation and wiring instructions in addition to requirements of all applicable codes, laws, and standards.

Activities including installation, adjustments, putting into service, use, assembly, disassembly, and maintenance are required to be carried out by suitably trained personnel in accordance with applicable code of practice.

If this equipment is used in a manner not specified by the manufacturer, the protection provided by the equipment may be impaired.

In no event will Rockwell Automation, Inc. be responsible or liable for indirect or consequential damages resulting from the use or application of this equipment.

The examples and diagrams in this manual are included solely for illustrative purposes. Because of the many variables and requirements associated with any particular installation, Rockwell Automation, Inc. cannot assume responsibility or liability for actual use based on the examples and diagrams.

No patent liability is assumed by Rockwell Automation, Inc. with respect to use of information, circuits, equipment, or software described in this manual.

Reproduction of the contents of this manual, in whole or in part, without written permission of Rockwell Automation, Inc., is prohibited.

Throughout this manual, when necessary, we use notes to make you aware of safety considerations.



WARNING: Identifies information about practices or circumstances that can cause an explosion in a hazardous environment, which may lead to personal injury or death, property damage, or economic loss.



ATTENTION: Identifies information about practices or circumstances that can lead to personal injury or death, property damage, or economic loss. Attentions help you identify a hazard, avoid a hazard, and recognize the consequence.

IMPORTANT

Identifies information that is critical for successful application and understanding of the product.

Labels may also be on or inside the equipment to provide specific precautions.



SHOCK HAZARD: Labels may be on or inside the equipment, for example, a drive or motor, to alert people that dangerous voltage may be present.



BURN HAZARD: Labels may be on or inside the equipment, for example, a drive or motor, to alert people that surfaces may reach dangerous temperatures.



ARC FLASH HAZARD: Labels may be on or inside the equipment, for example, a motor control center, to alert people to potential Arc Flash. Arc Flash will cause severe injury or death. Wear proper Personal Protective Equipment (PPE). Follow ALL Regulatory requirements for safe work practices and for Personal Protective Equipment (PPE).

Summary of Changes

The information below summarizes the changes to the PowerFlex 700 User Manual, publication 20B-UM001 since the last release.

Manual Updates

Description of New or Updated Information	Page
Removed the Installation/Wiring information (Chapter 1), Start Up information (Chapter 2), dimension, specification and fuse/breaker information (Appendix A). This information can now be found in the Installation Instructions: PowerFlex 700 Adjustable Frequency AC Drive – Frames 0...6, publication 20B-IN0019	–

Notes:

Table of Contents

		Important User Information	1-2
Preface	Overview	Who Should Use this Manual?	P-1
		What Is Not in this Manual	P-1
		Additional Resources	P-2
		Manual Conventions	P-2
		General Precautions	P-3
		Catalog Number Explanation	P-5
Chapter 1	Programming and Parameters	About Parameters	1-1
		How Parameters are Organized	1-3
		Monitor File	1-12
		Motor Control File	1-14
		Speed Command File	1-21
		Dynamic Control File	1-31
		Utility File	1-38
		Communication File	1-50
		Inputs & Outputs File	1-54
		Applications File	1-60
		Parameter Cross Reference – by Name . .	1-61
		Parameter Cross Reference – by Number	1-64
Chapter 2	Troubleshooting	Faults and Alarms	2-1
		Drive Status	2-2
		Manually Clearing Faults	2-3
		Fault Descriptions	2-4
		Clearing Alarms	2-9
		Alarm Descriptions	2-10
		Common Symptoms/Corrective Actions	2-13
		Testpoint Codes and Functions	2-16
Appendix A	Supplemental Drive Information	Drive Frame Sizes	A-1
		Communication Configurations	A-1
Appendix B	HIM Overview	External and Internal Connections	B-1
		LCD Display Elements	B-2
		ALT Functions	B-2
		Menu Structure	B-3
		Viewing and Editing Parameters	B-5
		Linking Parameters (Vector Control Only)	B-6
		Removing/Installing the HIM	B-8

Appendix C	Application Notes	External Brake Resistor	C-1
		Lifting/Torque Proving	C-2
		Minimum Speed	C-7
		Motor Control Technology	C-8
		Motor Overload	C-10
		Overspeed	C-11
		Power Loss Ride Through	C-12
		Process PI for Standard Control	C-13
		Reverse Speed Limit	C-16
		Skip Frequency	C-17
		Sleep Wake Mode	C-19
		Start At PowerUp.	C-21
		Stop Mode	C-22
Voltage Tolerance	C-24		

Index

Overview

The purpose of this manual is to provide you with the basic information needed to install, start-up and troubleshoot the PowerFlex 700 Adjustable Frequency AC Drive.

For information on . . .	See page . . .
Who Should Use this Manual?	P-1
What Is Not in this Manual	P-1
Additional Resources	P-2
Manual Conventions	P-2
General Precautions	P-3
Catalog Number Explanation	P-5

Who Should Use this Manual?

This manual is intended for qualified personnel. You must be able to program and operate Adjustable Frequency AC Drive devices. In addition, you must have an understanding of the parameter settings and functions.

What Is Not in this Manual

The PowerFlex 700 Series A User Manual provides programming and troubleshooting information for Standard Control and Vector Control drives, Frames 0...6.

Drive installation and wiring information is not in this manual, but can be found in the Installation Instructions for your drive:

Frames 0...6 – [publication 20B-IN019](#)

Literature is available online at <http://www.rockwellautomation.com/literature>.

Additional Resources

These documents contain additional information concerning related products from Rockwell Automation.

Resource	Description
PowerFlex 700 AC Drive Technical Data, publication 20B-TD001	This publication provides detailed drive specifications, option specifications and input protection device ratings.
PowerFlex Comm Adapter Manuals, publication 20COMM-UM...	These publications provide information on configuring, using, and troubleshooting PowerFlex communication adapters.
PowerFlex 70 and PowerFlex 700 Reference Manual, publication PFLEX-RM001	These publications provide detailed application specific information for programming and configuring the PowerFlex 700 drive.
PowerFlex 70 Enhanced Control and PowerFlex 700 Vector Control Reference Manual, publication PFLEX-RM004	
Wiring and Grounding Guidelines for Pulse Width Modulated (PWM) AC Drives, publication DRIVES-IN001	Provides basic information needed to properly wire and ground PWM AC drives.
Safety Guidelines for the Application, Installation and Maintenance of Solid State Control, publication SGI-1.1	Provides general guidelines for the application, installation, and maintenance of solid-state control.
Guarding Against Electrostatic Damage, publication 8000-4.5.2	Provides practices for guarding against Electrostatic damage (ESD)
Product Certifications website, http://ab.com	Provides declarations of conformity, certificates, and other certification details.

You can view or download publications at <http://www.rockwellautomation.com/literature/>. To order paper copies of technical documentation, contact your local Allen-Bradley distributor or Rockwell Automation sales representative.

Manual Conventions

- In this manual we refer to the PowerFlex 700 Adjustable Frequency AC Drive as; drive, PowerFlex 700 or PowerFlex 700 Drive.
- To help differentiate parameter names and LCD display text from other text, the following conventions will be used:
 - Parameter Names will appear in [brackets].
For example: [DC Bus Voltage].
 - Display Text will appear in “quotes.” For example: “Enabled.”

- The following words are used throughout the manual to describe an action:

Word	Meaning
Can	Possible, able to do something
Cannot	Not possible, not able to do something
May	Permitted, allowed
Must	Unavoidable, you must do this
Shall	Required and necessary
Should	Recommended
Should Not	Not recommended

General Precautions



ATTENTION: This drive contains ESD (Electrostatic Discharge) sensitive parts and assemblies. Static control precautions are required when installing, testing, servicing or repairing this assembly. Component damage may result if ESD control procedures are not followed. If you are not familiar with static control procedures, reference A-B publication 8000-4.5.2, “Guarding Against Electrostatic Damage” or any other applicable ESD protection handbook.



ATTENTION: An incorrectly applied or installed drive can result in component damage or a reduction in product life. Wiring or application errors, such as, undersizing the motor, incorrect or inadequate AC supply, or excessive ambient temperatures may result in malfunction of the system.



ATTENTION: Only qualified personnel familiar with adjustable frequency AC drives and associated machinery should plan or implement the installation, start-up and subsequent maintenance of the system. Failure to comply may result in personal injury and/or equipment damage.



ATTENTION: To avoid an electric shock hazard, verify that the voltage on the bus capacitors has discharged before performing any work on the drive. Measure the DC bus voltage at the +DC & –DC terminals of the Power Terminal Block (refer to Installation Instructions for location). The voltage must be zero.



ATTENTION: Risk of injury or equipment damage exists. DPI or SCANport host products must not be directly connected together via 1202 cables. Unpredictable behavior can result if two or more devices are connected in this manner.



ATTENTION: An incorrectly applied or installed bypass system can result in component damage or reduction in product life. The most common causes are:

- Wiring AC line to drive output or control terminals.
 - Improper bypass or output circuits not approved by Allen-Bradley.
 - Output circuits which do not connect directly to the motor.
- Contact Allen-Bradley for assistance with application or wiring.



ATTENTION: The “adjust freq” portion of the bus regulator function is extremely useful for preventing nuisance overvoltage faults resulting from aggressive decelerations, overhauling loads, and eccentric loads. It forces the output frequency to be greater than commanded frequency while the drive's bus voltage is increasing towards levels that would otherwise cause a fault. However, it can also cause either of the following two conditions to occur.

1. Fast positive changes in input voltage (more than a 10% increase within 6 minutes) can cause uncommanded positive speed changes. However an “OverSpeed Limit” fault will occur if the speed reaches [Max Speed] + [Overspeed Limit]. If this condition is unacceptable, action should be taken to 1) limit supply voltages within the specification of the drive and, 2) limit fast positive input voltage changes to less than 10%. Without taking such actions, if this operation is unacceptable, the “adjust freq” portion of the bus regulator function must be disabled (see parameters 161 and 162).
2. Actual deceleration times can be longer than commanded deceleration times. However, a “Decel Inhibit” fault is generated if the drive stops decelerating altogether. If this condition is unacceptable, the “adjust freq” portion of the bus regulator must be disabled (see parameters 161 and 162). In addition, installing a properly sized dynamic brake resistor will provide equal or better performance in most cases.

Important: These faults are not instantaneous. Test results have shown that they can take between 2-12 seconds to occur.



ATTENTION: Loss of control in suspended load applications can cause personal injury and/or equipment damage. Loads must always be controlled by the drive or a mechanical brake. Parameters 600-611 are designed for lifting/torque proving applications. It is the responsibility of the engineer and/or end user to configure drive parameters, test any lifting functionality and meet safety requirements in accordance with all applicable codes and standards.

Catalog Number Explanation

20B **D** **2P1** **A** **3** **A** **Y** **N** **A** **E** **C** **0** **NN** **AD**
a b c d e f g h i j k l m n

<i>a</i>	
Drive	
Code	Type
20B	PowerFlex 700

<i>b</i>				
Voltage Rating				
Code	Voltage	Ph.	Prechg.	Frames
B	240V AC	3	-	0...6
C	400V AC	3	-	0...6
D	480V AC	3	-	0...6
E	600V AC	3	-	0...6
F	690V AC	3	-	5...6
H	540V DC	-	N	5...6
J	650V DC	-	N	5...6
N	325V DC	-	Y	5...6
P	540V DC	-	Y	5...6
R	650V DC	-	Y	5...6
T	810V DC	-	Y	5...6
W	932V DC	-	Y	5...6

<i>c</i>			
ND Output Rating			
Example			
Code	Amps	kW (Hp)	
2P2	2.2	0.37 (0.5)	
022	22	5.5 (7.5)	

<i>d</i>	
Enclosure	
Code	Enclosure
A	IP20, NEMA/UL Type 1
F ▲	Open/Flange Mount
	Front: IP00, NEMA/UL Type Open Back/Heatsink: IP54, NEMA Type 12
G ▲	Stand-Alone/Wall Mount
	IP54, NEMA/UL Type 12

▲ Only available for Frame 5 & Frame 6 drives, 400...690V.

<i>e</i>	
HIM	
Code	Operator Interface
0	Blank Cover
3	LCD Display, Full Numeric Keypad
J +	Remote (Panel Mount), IP66, NEMA/UL Type 12 Full Numeric LCD HIM
K +	Remote (Panel Mount), IP66, NEMA/UL Type 12 Prog. Only LCD HIM

+ Available with Frames 5...6 Stand-Alone IP54 drives (Enclosure Code *G*).

<i>f</i>	
Documentation	
Code	Type
A	Manual
N	No Manual
Q	No Shipping Package (Internal Use Only)

<i>g</i>	
Brake	
Code	w/Brake IGBT †
Y	Yes
N	No

† Brake IGBT is standard on Frames 0-3, optional on Frames 4-6.

<i>h</i>	
Internal Braking Resistor	
Code	w/Resistor
Y	Yes *
N	No

* Not available for Frame 3 drives or larger.

<i>i</i>		
Emission		
Code	CE Filter §	CM Choke
A	Yes	Yes
B #	Yes	No
N	No	No

§ Note: 600V class drives below 77 Amps (Frames 0-4) are declared to meet the Low Voltage Directive. It is the responsibility of the user to determine compliance to the EMC directive.

Only available for 208...240V Frame 0-3 drives.

<i>j</i>	
Comm Slot	
Code	Network Type
C	ControlNet (Coax)
D	DeviceNet
E	EtherNet/IP
N	None

<i>k</i>		
Control & I/O		
Code	Control	I/O Volts
A	Standard	24V DC/AC
B	Standard	115V AC
C	Vector Δ	24V DC
D	Vector Δ	115V AC
N	Standard	None

Δ Vector Control Option utilizes DPI Only.

<i>l</i>	
Feedback	
Code	Type
0	None
1	Encoder, 12V/5V

<i>m</i>
Future Use

<i>n</i>	
Special Firmware (Frames 0...6 Only)	
Code	Type
AD +	60 Hz Maximum
AE +	Cascading Fan/Pump Control
AX +	82 Hz Maximum
BA +	Pump Off (for pump jack)

+ Must be used with Vector Control option C or D (Position k). Positions m-n are only required when custom firmware is supplied.

Notes:

Programming and Parameters

Chapter 3 provides a complete listing and description of the PowerFlex 700 parameters. The parameters can be programmed (viewed/edited) using an LCD HIM (Human Interface Module). As an alternative, programming can also be performed using DriveExplorer™ or DriveExecutive™ software and a personal computer. Refer to [Appendix B](#) for a brief description of the LCD HIM.

For information on . . .	See page . . .
About Parameters	1-1
How Parameters are Organized	1-3
Monitor File	1-12
Motor Control File	1-14
Speed Command File	1-21
Dynamic Control File	1-31
Utility File	1-38
Communication File	1-50
Inputs & Outputs File	1-54
Applications File	1-60
Parameter Cross Reference – by Name	1-62
Parameter Cross Reference – by Number	1-65





About Parameters

To configure a drive to operate in a specific way, drive parameters may have to be set. Three types of parameters exist:

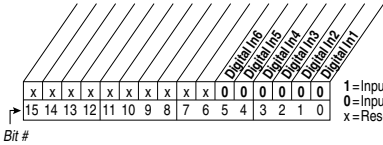
- **ENUM Parameters**
ENUM parameters allow a selection from 2 or more items. The LCD HIM will display a text message for each item.
- **Bit Parameters**
Bit parameters have individual bits associated with features or conditions. If the bit is 0, the feature is off or the condition is false. If the bit is 1, the feature is on or the condition is true.
- **Numeric Parameters**
These parameters have a single numerical value (i.e. 0.1 Volts).

The example on the following page shows how each parameter type is presented in this manual.

1	2	3	4	5	6
File	Group	No.	Parameter Name & Description	Values	Related
UTILITY	Drive ...	198	[Load Frm Usr Set] Loads a previously saved set of parameter values from a selected user set location in drive nonvolatile memory to active drive memory.	Default: 0 "Ready" Options: 0 "Ready" 1 "User Set 1" 2 "User Set 2" 3 "User Set 3"	199 7
		216	[Dig In Status] Status of the digital inputs. 		1=Input Present 0=Input Not Present x=Reserved
MOTOR...	Torq...	434	Vector [Torque Ref B Mult] Defines the value of the multiplier for the [Torque Ref B Sel] selection.	Default: 1.0 Min/Max: -/+32767.0 Units: 0.1	

No.	Description															
1	File – Lists the major parameter file category.															
2	Group – Lists the parameter group within a file.															
3	No. – Parameter number.  = Parameter value can not be changed until drive is stopped.  = 32 bit parameter in the Standard Control option. All parameters in the Vector Control option are 32 bit.  = Parameter only displayed when [Motor Cntl Sel] is set to "4."															
4	Parameter Name & Description – Parameter name as it appears on an LCD HIM, with a brief description of the parameters function. Standard = This parameter is specific to the Standard Control Option. Vector = This parameter will only be available with the Vector Control option. Vector v3 = Only available with Vector Control option firmware version 3.xxx & later.															
5	Values – Defines the various operating characteristics of the parameter. Three types exist. <table border="1" data-bbox="150 1085 890 1436"> <tr> <td>ENUM</td> <td>Default:</td> <td>Lists the value assigned at the factory. "Read Only" = no default.</td> </tr> <tr> <td></td> <td>Options:</td> <td>Displays the programming selections available.</td> </tr> <tr> <td>Bit</td> <td>Bit:</td> <td>Lists the bit place holder and definition for each bit.</td> </tr> <tr> <td rowspan="2">Numeric</td> <td>Default:</td> <td>Lists the value assigned at the factory. "Read Only" = no default.</td> </tr> <tr> <td>Min/Max: Units:</td> <td>The range (lowest and highest setting) possible for the parameter. Unit of measure and resolution as shown on the LCD HIM.</td> </tr> </table> <p>Important: Some parameters will have two unit values:</p> <ul style="list-style-type: none"> Analog inputs can be set for current or voltage with [Anlg In Config], param. 320. Setting [Speed Units], parameter 79 on Vector Control drives selects Hz or RPM. Values that pertain to Vector Control drives only will be indicated by "Vector" or "v3" for Vector firmware 3.xxx and later. <p>Important: When sending values through DPI ports, simply remove the decimal point to arrive at the correct value (i.e. to send "5.00 Hz," use "500").</p>		ENUM	Default:	Lists the value assigned at the factory. "Read Only" = no default.		Options:	Displays the programming selections available.	Bit	Bit:	Lists the bit place holder and definition for each bit.	Numeric	Default:	Lists the value assigned at the factory. "Read Only" = no default.	Min/Max: Units:	The range (lowest and highest setting) possible for the parameter. Unit of measure and resolution as shown on the LCD HIM.
ENUM	Default:	Lists the value assigned at the factory. "Read Only" = no default.														
	Options:	Displays the programming selections available.														
Bit	Bit:	Lists the bit place holder and definition for each bit.														
Numeric	Default:	Lists the value assigned at the factory. "Read Only" = no default.														
	Min/Max: Units:	The range (lowest and highest setting) possible for the parameter. Unit of measure and resolution as shown on the LCD HIM.														
6	Related – Lists parameters (if any) that interact with the selected parameter. The symbol  indicates that additional parameter information is available in Appendix C.															

How Parameters are Organized

The LCD HIM displays parameters in a **File-Group-Parameter** or **Numbered List** view order. To switch display mode, access the Main Menu, press ALT, then Sel while cursor is on the parameter selection. In addition, using [\[Param Access Lvl\]](#), the user has the option to display *all* parameters, commonly used parameters or diagnostic parameters.

Control Options

Two different control options are available for the PowerFlex 700; Standard and Vector. The Standard Control option provides typical Volts per Hertz and Sensorless Vector operation. The Vector Control option provides the added capability of FVC Vector control. The cassette determines the type of control you have available (see diagram).

To simplify programming with the Vector Control option, the displayed parameters will change according to the selection made with [\[Motor Cntl Sel\]](#). For example, if “FVC Vector” is selected, the parameters associated solely with other operations such as Volts per Hertz or Sensorless Vector will be hidden. Refer to pages [1-4](#) through [1-8](#).

Standard Control
Option

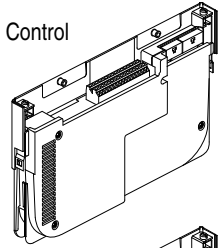

Vector Control
Option

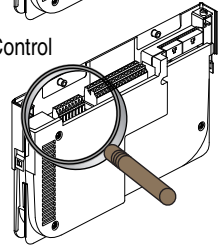

File-Group-Parameter Order







This simplifies programming by grouping parameters that are used for similar functions. The parameters are organized into files. Each file is divided into groups, and each parameter is an element in a group. By default, the LCD HIM displays parameters by File-Group-Parameter view.

Numbered List View

All parameters are in numerical order.







Basic Parameter View – Standard Control Option

Parameter 196 [Param Access Lvl] set to option 0 “Basic.”

File	Group	Parameters					
	Metering	Output Freq	001				
		Commanded Freq	002				
		Output Current	003				
		DC Bus Voltage	012				
	Motor Data	Motor NP Volts	041	Motor NP RPM	044	Motor OL Hertz	047
		Motor NP FLA	042	Motor NP Power	045		
		Motor NP Hertz	043	Mtr NP Pwr Units	046		
	Torq Attributes	Torque Perf Mode	053	Maximum Freq	055		
		Maximum Voltage	054	Autotune	061		
	Spd Mode & Limits	Minimum Speed	081				
		Maximum Speed	082				
	Speed References	Speed Ref A Sel	090	Speed Ref B Hi	094	TB Man Ref Sel	096
		Speed Ref B Sel	093	Speed Ref A Lo	092	TB Man Ref Hi	097
		Speed Ref A Hi	091	Speed Ref B Lo	095	TB Man Ref Lo	098
	Discrete Speeds	Jog Speed	100				
Preset Speed 1-7		101-107					
	Ramp Rates	Accel Time 1	140	Decel Time 1	142	S-Curve %	146
		Accel Time 2	141	Decel Time 2	143		
	Load Limits	Current Lmt Sel	147				
		Current Lmt Val	148				
	Stop/Brake Modes	Stop Mode A	155	DC Brk Lvl Sel	157	Bus Reg Mode A	161
		Stop Mode B	156	DC Brake Level	158	Bus Reg Mode B	162
				DC Brake Time	159	DB Resistor Type	163
	Restart Modes	Start At PowerUp	168	Auto Rstrt Tries	174	Auto Rstrt Delay	175
	Power Loss	Power Loss Mode	184	Power Loss Time	185		
		Direction Config	Direction Mode	190			
Drive Memory		Param Access Lvl	196	Save To User Set	199		
		Reset To Defaults	197	Language	201		
		Load Frm Usr Set	198				
Faults		Fault Config 1	238				
	Analog Inputs	Anlg In Config	320	Analog In1 Lo	323		
		Analog In1 Hi	322	Analog In2 Lo	326		
		Analog In2 Hi	325				
	Analog Outputs	Analog Out1 Sel	342				
		Analog Out1 Hi	343				
		Analog Out1 Lo	344				
	Digital Inputs	Digital In1-6 Sel	361-366				
	Digital Outputs	Digital Out1 Sel	380	Dig Out1 Level	381		
		Digital Out2 Sel	384	Dig Out2 Level	385		

Basic Parameter View – Vector Control Option





Parameter 196 [Param Access Lvl] set to option 0 “Basic.”



File	Group	Parameters						
	Metering	Output Freq	001					
		Commanded Speed	002					
		Commanded Torque**	024					
		Output Current	003					
		Torque Current	004					
		DC Bus Voltage	012					
	Motor Data	Motor NP Volts	041	Motor NP RPM	044	Motor OL Hertz	047	
		Motor NP FLA	042	Motor NP Power	045	Motor Poles	049	
		Motor NP Hertz	043	Mtr NP Pwr Units	046			
	Torq Attributes	Motor Cntl Sel	053	Autotune Torque**	066	Torque Ref A Lo**	429	
		Maximum Voltage	054	Inertia Autotune**	067	Pos Torque Limit**	436	
		Maximum Freq	055	Torque Ref A Sel**	427	Neg Torque Limit**	437	
		Autotune	061	Torque Ref A Hi**	428			
	Speed Feedback	Motor Fdbk Type	412	Encoder PPR	413			
	Spd Mode & Limits	Speed Units	079	Minimum Speed	081	Rev Speed Limit**	454	
		Feedback Select	080	Maximum Speed	082			
	Speed References	Speed Ref A Sel	090	Speed Ref B Hi	094	TB Man Ref Lo	098	
		Speed Ref A Hi	091	Speed Ref B Lo	095	Pulse Input Ref	099	
		Speed Ref A Lo	092	TB Man Ref Sel	096			
		Speed Ref B Sel	093	TB Man Ref Hi	097			
	Discrete Speeds	Jog Speed 1	100	Jog Speed 2	108			
		Preset Speed 1-7	101-107					
		Ramp Rates	Accel Time 1	140	Decel Time 1	142	S-Curve %	146
			Accel Time 2	141	Decel Time 2	143		
Load Limits		Current Lmt Sel	147	Current Lmt Val	148			
Stop/Brake Modes		Stop/Brk Mode A	155	DC Brk Lvl Sel	157	Bus Reg Mode A	161	
		Stop/Brk Mode B	156	DC Brake Level	158	Bus Reg Mode B	162	
				DC Brake Time	159	DB Resistor Type	163	
Restart Modes		Start At PowerUp	168	Auto Rstrt Tries	174	Auto Rstrt Delay	175	
Power Loss		Power Loss Mode	184	Power Loss Time	185	Power Loss Level	186	
	Direction Config	Direction Mode	190					
	Drive Memory	Param Access Lvl	196	Load Frm Usr Set	198	Language	201	
		Reset To Defaults	197	Save To User Set	199			
	Diagnostics	Start Inhibits	214	Dig In Status	216	Dig Out Status	217	
	Faults	Fault Config 1	238					
	Alarms	Alarm Config 1	259					
	Analog Inputs	Anlg In Config	320	Analog In2 Hi	325			
		Analog In1 Hi	322	Analog In2 Lo	326			
		Analog In1 Lo	323					
	Analog Outputs	Analog Out1, 2 Sel	342	Analog Out1, 2 Lo	344	Analog Out2 Hi	346	
		Analog Out1 Hi	343	Analog Out1, 2 Sel	345	Analog Out1, 2 Lo	347	
	Digital Inputs	Digital In1-6 Sel	361-366					
	Digital Outputs	Digital Out1-3 Sel	380-388	Dig Out1-3 Level	381-389			

** These parameters will only be displayed when parameter 053 [Motor Cntl Sel] is set to option “4.”

Advanced Parameter View – Standard Control Option





Parameter 196 [Param Access Lvl] set to option 1 “Advanced.”





File	Group	Parameters						
	Metering	Output Freq	001	Output Voltage	006	MOP Frequency	011	
		Commanded Freq	002	Output Power	007	DC Bus Voltage	012	
		Output Current	003	Output Pwr Fctr	008	DC Bus Memory	013	
		Torque Current	004	Elapsed MWh	009	Analog In1 Value	016	
		Flux Current	005	Elapsed Run Time	010	Analog In2 Value	017	
	Drive Data	Rated kW	026	Rated Amps	028			
		Rated Volts	027	Control SW Ver	029			
		Motor Data	Motor Type	040	Motor NP RPM	044	Motor OL Factor	048
			Motor NP Volts	041	Motor NP Power	045		
			Motor NP FLA	042	Mtr NP Pwr Units	046		
Motor NP Hertz			043	Motor OL Hertz	047			
Torq Attributes		Torque Perf Mode	053	Flux Up Mode	057	IR Voltage Drop	062	
		Maximum Voltage	054	Flux Up Time	058	Flux Current Ref	063	
		Maximum Freq	055	SV Boost Filter	059	IXo Voltage Drop	064	
		Compensation	056	Autotune	061			
Volts per Hertz		Start/Acc Boost	069	Break Voltage	071			
		Run Boost	070	Break Frequency	072			
		Spd Mode & Limits	Speed Mode	080	Overspeed Limit	083	Skip Frequency 3	086
			Minimum Speed	081	Skip Frequency 1	084	Skip Freq Band	087
			Maximum Speed	082	Skip Frequency 2	085		
		Speed References	Speed Ref A Sel	090	Speed Ref B Sel	093	TB Man Ref Sel	096
	Speed Ref A Hi		091	Speed Ref B Hi	094	TB Man Ref Hi	097	
	Speed Ref A Lo		092	Speed Ref B Lo	095	TB Man Ref Lo	098	
	Discrete Speeds	Jog Speed	100					
		Preset Speed 1-7	101-107					
	Speed Trim	Trim In Select	117	Trim Hi	119			
		Trim Out Select	118	Trim Lo	120			
	Slip Comp	Slip RPM @ FLA	121	Slip RPM Meter	123			
		Slip Comp Gain	122					
	Process PI	PI Configuration	124	PI Integral Time	129	PI Status	134	
		PI Control	125	PI Prop Gain	130	PI Ref Meter	135	
		PI Reference Sel	126	PI Lower Limit	131	PI Fdback Meter	136	
		PI Setpoint	127	PI Upper Limit	132	PI Error Meter	137	
		PI Feedback Sel	128	PI Preload	133	PI Output Meter	138	
	Ramp Rates	Accel Time 1	140	Decel Time 1	142	S Curve %	146	
		Accel Time 2	141	Decel Time 2	143			
	Load Limits	Current Lmt Sel	147	Drive OL Mode	150			
		Current Lmt Val	148	PWM Frequency	151			
		Current Lmt Gain	149					
	Stop/Brake Modes	Stop Mode A	155	DC Brake Time	159	DB Resistor Type	163	
		Stop Mode B	156	Bus Reg Ki	160	Bus Reg Kp	164	
		DC Brake Lvl Sel	157	Bus Reg Mode A	161	Bus Reg Kd	165	
		DC Brake Level	158	Bus Reg Mode B	162			
	Restart Modes	Start At PowerUp	168	Auto Rstrt Delay	175	Wake Time	181	
		Flying Start En	169	Sleep Wake-Mode	178	Sleep Level	182	
		Flying StartGain	170	Sleep-Wake Ref	179	Sleep Time	183	
		Auto Rstrt Tries	174	Wake Level	180			
	Power Loss	Power Loss Mode	184					
		Power Loss Time	185					
Power Loss Level		186						

File	Group	Parameters					
	Direction Config	Direction Mode	190				
	HIM Ref Config	Save HIM Ref	192				
		Man Ref Preload	193				
	MOP Config	Save MOP Ref	194				
		MOP Rate	195				
	Drive Memory	Param Access Lvl	196	Save To User Set	199	Voltage Class	202
		Reset To Defaults	197	Reset Meters	200	Drive Checksum	203
		Load Frm Usr Set	198	Language	201		
	Diagnostics	Drive Status 1	209	Dig Out Status	217	Status 2 @ Fault	228
		Drive Status 2	210	Drive Temp	218	Alarm 1 @ Fault	229
		Drive Alarm 1	211	Drive OL Count	219	Alarm 2 @ Fault	230
Drive Alarm 2		212	Motor OL Count	220	Testpoint 1 Sel	234	
Speed Ref Source		213	Fault Speed	224	Testpoint 1 Data	235	
Start Inhibits		214	Fault Amps	225	Testpoint 2 Sel	236	
Last Stop Source		215	Fault Bus Volts	226	Testpoint 2 Data	237	
Dig In Status		216	Status 1 @ Fault	227			
Faults	Fault Config 1	238	Fault Clear Mode	241	Fault 1-8 Code	243-257	
	Fault Clear	240	Power Up Marker	242	Fault 1-8 Time	244-258	
Alarms	Alarm Config 1	259	Alarm1-8 Code	262-269			
	Alarm Clear	261					
	Comm Control	DPI Baud Rate	270	Drive Ref Rslt	272		
		Drive Logic Rslt	271	Drive Ramp Rslt	273		
	Masks & Owners	Logic Mask	276	Fault Clr Mask	283	Reference Owner	292
		Start Mask	277	MOP Mask	284	Accel Owner	293
		Jog Mask	278	Local Mask	285	Decel Owner	294
		Direction Mask	279	Stop Owner	288	Fault Clr Owner	295
		Reference Mask	280	Start Owner	289	MOP Owner	296
		Accel Mask	281	Jog Owner	290	Local Owner	297
		Decel Mask	282	Direction Owner	291		
	DataLinks	Data In A1-D2	300-307				
		Data Out A1-D2	310-317				
		Analog Inputs	Anlg In Config	320	Analog In 2 Hi	325	Anlg In 1 Loss
Anlg In Sqr Root			321	Analog In 1 Lo	323	Anlg In 2 Loss	327
Analog In 1 Hi			322	Analog In 2 Lo	326		
Analog Outputs		Anlg Out Config	340	Analog Out1 Hi	343		
		Anlg Out Absolut	341	Analog Out1 Lo	344		
		Analog Out1 Sel	342				
Digital Inputs		Digital In1-6 Sel	361-366				
Digital Outputs		Digital Out1 Sel	380	Dig Out2 Level	385	Dig Out1 OffTime	383
		Digital Out2 Sel	384	Dig Out1 OnTime	382	Dig Out2 OffTime	387
		Dig Out1 Level	381	Dig Out2 OnTime	386		

Advanced Parameter View – Vector Control Option

Parameter 196 [Param Access Lvl] set to option 1 “Advanced.”

File	Group	Parameters						
	Metering	Output Freq	001	Torque Current	004	MOP Reference	011	
		Commanded Speed	002	Flux Current	005	DC Bus Voltage	012	
		Ramped Speed	022	Output Voltage	006	DC Bus Memory	013	
	Drive Data	Speed Reference	023	Output Power	007	Analog In1 Value	016	
		Commanded Torque**024		Output Powr Fctr	008	Analog In2 Value	017	
		Speed Feedback	025	Elapsed MWh	009	Elapsed kWh	014 ^{3.x}	
		Output Current	003	Elapsed Run Time	010			
		Rated kW	026	Rated Amps	028			
		Rated Volts	027	Control SW Ver	029			
	Motor Data	Motor Type	040	Motor NP RPM	044	Motor OL Factor	048	
		Motor NP Volts	041	Motor NP Power	045	Motor Poles	049	
		Motor NP FLA	042	Mtr NP Pwr Units	046			
		Motor NP Hertz	043	Motor OL Hertz	047			
	Torq Attributes	Motor Cntl Sel	053	Flux Current Ref	063	Torque Ref B Hi**	432	
		Maximum Voltage	054	Ixo Voltage Drop	064	Torque Ref B Lo**	433	
		Maximum Freq	055	Autotune Torque**	066	Torq Ref B Mult**	434	
		Compensation	056	Inertia Autotune**	067	Torque Setpoint**	435	
		Flux Up Mode	057	Torque Ref A Sel**	427	Torque Setpoint 2**	438 ^{3.x}	
		Flux Up Time	058	Torque Ref A Hi**	428	Pos Torque Limit**	436	
		SV Boost Filter	059	Torque Ref A Lo**	429	Neg Torque Limit**	437	
		Autotune	061	Torq Ref A Div**	430	Control Status**	440	
		IR Voltage Drop	062	Torque Ref B**	431	Mtr Tor Cur Ref**	441	
		Volts per Hertz	Start/Acc Boost	069	Break Voltage*	071		
	Run Boost*		070	Break Frequency*	072			
	Speed Feedback	Motor Fdbk Type	412	Fdbk Filter Sel	416	Marker Pulse	421	
		Encoder PPR	413	Notch Filter Freq**	419	Pulse In Scale	422	
		Enc Position Fdbk	414	Notch Filter K**	420	Encoder Z Chan	423	
		Encoder Speed	415					
		Spd Mode & Limits	Speed Units	079	Overspeed Limit	083	Skip Freq Band*	087
			Feedback Select	080	Skip Frequency 1*	084	Speed/Torque Mod**	088
			Minimum Speed	081	Skip Frequency 2*	085	Rev Speed Limit**	454
			Maximum Speed	082	Skip Frequency 3*	086		
		Speed References	Speed Ref A Sel	090	Speed Ref B Hi	094	TB Man Ref Hi	097
			Speed Ref A Hi	091	Speed Ref B Lo	095	TB Man Ref Lo	098
			Speed Ref A Lo	092	TB Man Ref Sel	096	Pulse Input Ref	099
			Speed Ref B Sel	093				
Discrete Speeds		Jog Speed 1	100	Preset Speed 1-7	101-107	Jog Speed 2	108	
Speed Trim		Trim In Select	117	Trim Hi	119	Trim % Setpoint	116 ^{3.x}	
		Trim Out Select	118	Trim Lo	120			
Slip Comp		Slip RPM @ FLA	121	Slip Comp Gain*	122	Slip RPM Meter	123	
Process PI		PI Configuration	124	PI Lower Limit	131	PI Output Meter	138	
		PI Control	125	PI Upper Limit	132	PI Reference Hi	460	
		PI Reference Sel	126	PI Preload	133	PI Reference Lo	461	
	PI Setpoint	127	PI Status	134	PI Feedback Hi	462		
	PI Feedback Sel	128	PI Ref Meter	135	PI Feedback Lo	463		
	PI Integral Time	129	PI Fdbk Meter	136	PI BW Filter	139 ^{2.x}		
	PI Prop Gain	130	PI Error Meter	137	PI Deriv Time	459 ^{3.x}		
Speed Regulator	Ki Speed Loop**	445	Kf Speed Loop**	447	Total Inertia**	450		
	Kp Speed Loop**	446	Speed Desired BW**	449	Speed Loop Meter**	451 ^{3.x}		
	Ramp Rates	Accel Time 1, 2	140,141	Decel Time 1, 2	142,143	S Curve %	146	
		Current Lmt Sel	147	Drive OL Mode	150	Regen Power Limit**	153	
	Load Limits	Current Lmt Val	148	PWM Frequency	151	Current Rate Limit**	154	
		Current Lmt Gain	149	Droop RPM @ FLA152				

File	Group	Parameters						
 Dynamic Control <i>continued</i>	Stop/Brake Modes	Stop/Brk Mode	155,156	Bus Reg Ki*	160	Bus Reg Kd*	165	
		DC Brk Lvl Sel	157	Bus Reg Mode	161,162	Flux Braking	166	
		DC Brake Level	158	DB Resistor Type	163	DB While Stopped	145 ^{3.x}	
		DC Brake Time	159	Bus Reg Kp*	164			
		Restart Modes	Start At PowerUp	168	Auto Rstrt Delay	175	Wake Time	181
		Flying Start En	169	Sleep-Wake Mode	178	Sleep Level	182	
		Flying StartGain	170	Sleep-Wake Ref	179	Sleep Time	183	
		Auto Rstrt Tries	174	Wake Level	180	Powerup Delay	167	
		Power Loss	Power Loss Mode	184	Load Loss Level	187 ^{3.x}	Gnd Warn Level	177 ^{3.x}
			Power Loss Time	185	Reset Meters	200		
			Power Loss Level	186	Language	201		
					Shear Pin Time	189 ^{3.x}		
	 Utility	Direction Config	Direction Mode	190				
HIM Ref Config		Save HIM Ref	192	Man Ref Preload	193			
MOP Config		Save MOP Ref	194	MOP Rate	195			
Drive Memory		Param Access Lvl	196	Save To User Set	199	Voltage Class	202	
		Reset To Defaults	197	Reset Meters	200	Drive Checksum	203	
		Load Frm Usr Set	198	Language	201			
Diagnostics		Drive Status 1, 2	209,210	Dig Out Status	217	Fault Bus Volts	226	
		Drive Alarm 1, 2	211,212	Drive Temp	218	Status 1,2 @ Fault	227,228	
		Speed Ref Source	213	Drive OL Count	219	Alarm 1,2 @ Fault	229,230	
		Start Inhibits	214	Motor OL Count	220	Testpoint 1,2 Sel	234,236	
		Last Stop Source	215	Fault Speed	224	Testpoint 1,2 Data	235,237	
		Dig In Status	216	Fault Amps	225			
Faults		Fault Config 1	238	Fault Clear Mode	241	Fault 1-8 Code	243-257	
		Fault Clear	240	Power Up Marker	242	Fault 1-8 Time	244-258	
Alarms		Alarm Config 1	259	Alarm Clear	261	Alarm1-8 Code	262-269	
Scaled Blocks		Scale1, 2 In Val	476,482	Scale1, 2 In Lo	478,484	Scale1,2 Out Lo	480,486	
		Scale3, 4 In Val	488,494 ^{3.x}	Scale3, 4 In Lo	490,496 ^{3.x}	Scale3,4 Out Lo	492,488 ^{3.x}	
		Scale1, 2 In Hi	477,483	Scale1, 2 Out Hi	479,485	Scale1,2 Out Val	481,487	
		Scale3, 4 In Hi	489,495 ^{3.x}	Scale3, 4 Out Hi	491,497 ^{3.x}	Scale3,4 Out Val	493,499 ^{3.x}	
 Communication		Comm Control	DPI Baud Rate	270	Drive Ref Rslt	272	DPI Port Sel	274
			Drive Logic Rslt	271	Drive Ramp Rslt	273	DPI Port Value	275
		Masks & Owners	Logic Mask	276	MOP Mask	284	Decel Owner	294
			Start Mask	277	Local Mask	285	Fault Cir Owner	295
			Jog Mask	278	Stop Owner	288	MOP Owner	296
			Direction Mask	279	Start Owner	289	Local Owner	297
	Reference Mask		280	Jog Owner	290	DPI Ref Select	298 ^{3.x}	
	Accel Mask		281	Direction Owner	291	DPI Fdbk Select	299 ^{3.x}	
	Decel Mask		282	Reference Owner	292			
	Fault Cir Mask		283	Accel Owner	293			
	DataLinks	Data In A1-D2	300-307	Data Out A1-D2	310-317			
	 Inputs & Outputs	Analog Inputs	Anlg In Config	320	Analog In1, 2 Hi	322,325	Analog In1, 2 Loss	324,327
			Anlg In Sqr Root	321	Analog In1, 2 Lo	323,326		
		Analog Outputs	Anlg Out Config	340	Analog Out1, 2 Hi	343,346	Anlg Out1,2 Scal	354,355 ^{3.x}
			Anlg Out Absolut	341	Analog Out1, 2 Lo	344,347	Anlg1 Out Setpt	377,378 ^{3.x}
			Analog Out1, 2 Sel	342,345				
		Digital Inputs	Digital In1-6 Sel	361-366				
	Digital Outputs	Digital Out Sel	380,384,388	Dig Out OnTime	382,386,390	Dig Out Setpt	379 ^{3.x}	
Dig Out Level		381,385,389	Dig Out OffTime	383,387,391				
 Applications ^{3.x}	Torq Proving ^{3.x}	TorqProve Cnfg	600 ^{3.x}	Brk Release Time	604 ^{3.x}	TorqLim SlewRate	608 ^{3.x}	
		TorqProve Setup	601 ^{3.x}	ZeroSpdFloatTime	605 ^{3.x}	BrkSlip Count	609 ^{3.x}	
		Spd Dev Band	602 ^{3.x}	Float Tolerance	606 ^{3.x}	Brk Alarm Travel	610 ^{3.x}	
		SpdBand Integrat	603 ^{3.x}	Brk Set Time	607 ^{3.x}	MicroPos Scale%	611 ^{3.x}	







* These parameters will only be displayed when parameter 053 [Motor Cntl Sel] is set to option "2 or 3."

** These parameters will only be displayed when parameter 053 [Motor Cntl Sel] is set to option "4."

^{2.x} Firmware 2.001 & later only. ^{3.x} Firmware 3.001 & later only.

Basic Fan/Pump Parameter View⁽¹⁾ – Standard Control Option







Parameter 196 [Param Access Lvl] set to option 3 “Fan/Pump.”

File	Group	Parameters			
	Metering	Output Freq	001	Elapsed MWh	009
		Commanded Freq	002	Elapsed Run Time	010
		Output Current	003	DC Bus Voltage	012
		Output Power	007	Analog In1 Value	016
	Motor Data	Motor NP Volts	041	Motor NP RPM	044
		Motor NP FLA	042	Motor NP Power	045
		Motor NP Hertz	043	Mtr NP Pwr Units	046
	Torq Attributes	Maximum Voltage	054		
		Maximum Freq	055		
	Volts per Hertz	Start/Acc Boost	069	Break Voltage	071
Run Boost		070	Break Frequency	072	
	Spd Mode & Limits	Speed Mode	080	Overspeed Limit	083
		Minimum Speed	081	Skip Frequency 1	084
		Maximum Speed	082	Skip Freq Band	087
	Speed References	Speed Ref A Sel	090		
		Speed Ref A Hi	091		
		Speed Ref A Lo	092		
	Discrete Speeds	Preset Speed 2	102		
	Ramp Rates	Accel Time 1	140		
		Decel Time 1	142		
	Load Limits	Current Lmt Val	148		
	Stop/Brake Modes	Stop Mode A	155		
	Restart Modes	Start At PowerUp	168		
	Auto Rstrt Tries	174			
	Auto Rstrt Delay	175			
	Drive Memory	Param Access Lvl	196		
		Reset To Defaults	197		
		Language	201		
Diagnostics	Start Inhibits	214			
	Dig In Status	216			
	Dig Out Status	217			
	Analog Inputs	Anlg In Config	320	Analog In 1 Lo	323
		Anlg In Sqr Root	321	Anlg In 1 Loss	324
		Analog In 1 Hi	322		
	Analog Outputs	Anlg Out Config	340	Analog Out1 Hi	343
		Analog Out1 Sel	342	Analog Out1 Lo	344
	Digital Inputs	Digital In1-6 Sel	361-366		
	Digital Outputs	Digital Out1 Sel	380	Dig Out2 Level	385
		Digital Out2 Sel	384		
Dig Out1 Level		381			

⁽¹⁾ Only available on Standard Control drives with firmware version 3.001 or above.



Advanced Fan/Pump Parameter View⁽¹⁾ – Standard Control Option

Parameter 196 [Param Access Lvl] set to option 4 “Adv Fan/Pump.”

File	Group	Parameters					
	Metering	Output Freq	001	Elapsed Run Time	010		
		Commanded Freq	002	DC Bus Voltage	012		
		Output Current	003	Analog In1 Value	016		
		Output Power	007	Analog In2 Value	017		
		Elapsed MWh	009				
	Motor Data	Motor NP Volts	041	Motor NP Hertz	043	Motor NP Power	045
		Motor NP FLA	042	Motor NP RPM	044	Mtr NP Pwr Units	046
	Torq Attributes	Torque Perf Mode	053	Maximum Freq	055		
		Maximum Voltage	054				
	Volts per Hertz	Start/Acc Boost	069	Break Voltage	071		
		Run Boost	070	Break Frequency	072		
	Spd Mode & Limits	Speed Mode	080	Overspeed Limit	083	Skip Frequency 3	086
		Minimum Speed	081	Skip Frequency 1	084	Skip Freq Band	087
		Maximum Speed	082	Skip Frequency 2	085		
	Speed References	Speed Ref A Sel	090	Speed Ref A Lo	092	Speed Ref B Hi	094
		Speed Ref A Hi	091	Speed Ref B Sel	093	Speed Ref B Lo	095
	Discrete Speeds	Preset Speed 2-4	102-104				
	Process PI	PI Configuration	124	PI Integral Time	129	PI Status	134
		PI Control	125	PI Prop Gain	130	PI Ref Meter	135
		PI Reference Sel	126	PI Lower Limit	131	PI Fdback Meter	136
		PI Setpoint	127	PI Upper Limit	132	PI Error Meter	137
PI Feedback Sel		128	PI Preload	133	PI Output Meter	138	
	Ramp Rates	Accel Time 1	140	Decel Time 1	142	S Curve %	146
		Accel Time 2	141	Decel Time 2	143		
	Load Limits	Current Lmt Val	148	PWM Frequency	151		
		Stop/Brake Modes	Stop Mode A	155			
	Restart Modes	Start At PowerUp	168	Auto Rstrt Delay	175	Wake Time	181
		Flying Start En	169	Sleep Wake-Mode	178	Sleep Level	182
		Flying StartGain	170	Sleep-Wake Ref	179	Sleep Time	183
		Auto Rstrt Tries	174	Wake Level	180		
Power Loss	Power Loss Mode	184	Power Loss Time	185			
	Direction Config	Direction Mode	190				
	HIM Ref Config	Save HIM Ref	192	Man Ref Preload	193		
	Drive Memory	Param Access Lvl	196	Reset To Defaults	197	Language	201
	Diagnostics	Start Inhibits	214	Dig Out Status	217		
		Dig In Status	216				
	Analog Inputs	Anlg In Config	320	Analog In 2 Hi	325	Anlg In 1 Loss	324
		Anlg In Sqr Root	321	Analog In 1 Lo	323	Anlg In 2 Loss	327
		Analog In 1 Hi	322	Analog In 2 Lo	326		
	Analog Outputs	Anlg Out Config	340	Analog Out1 Hi	343		
		Analog Out1 Sel	342	Analog Out1 Lo	344		
	Digital Inputs	Digital In1-6 Sel	361-366				
	Digital Outputs	Digital Out1 Sel	380	Dig Out2 Level	385	Dig Out1 OffTime	383
		Digital Out2 Sel	384	Dig Out1 OnTime	382	Dig Out2 OffTime	387
Dig Out1 Level		381	Dig Out2 OnTime	386			

⁽¹⁾ Only available on Standard Control drives with firmware version 3.001 or above.

Monitor File











File	Group	No.	Parameter Name & Description <i>See page 1-2 for symbol descriptions</i>	Values	Related
MONITOR	Metering	001	[Output Freq] Output frequency present at T1, T2 & T3 (U, V & W)	Default: Read Only Min/Max: -/+ [Maximum Freq] Units: 0.1 Hz	
		002	Standard [Commanded Freq] Value of the active frequency command.	Default: Read Only Min/Max: -/+ [Maximum Speed] Units: 0.1 Hz	
			Vector [Commanded Speed] Value of the active Speed/Frequency Reference. Displayed in Hz or RPM, depending on value of [Speed Units].	Default: Read Only Min/Max: -/+ [Maximum Speed] Units: 0.1 Hz 0.1 RPM	079
		003	[Output Current] The total output current present at T1, T2 & T3 (U, V & W).	Default: Read Only Min/Max: 0.0/Drive Rated Amps × 2 Units: 0.1 Amps	
		004	[Torque Current] Based on the motor, the amount of current that is in phase with the fundamental voltage component.	Default: Read Only Min/Max: Drive Rating × -2/+2 Units: 0.1 Amps	
		005	[Flux Current] Amount of current that is out of phase with the fundamental voltage component.	Default: Read Only Min/Max: Drive Rating × -2/+2 Units: 0.1 Amps	
		006	[Output Voltage] Output voltage present at terminals T1, T2 & T3 (U, V & W).	Default: Read Only Min/Max: 0.0/Drive Rated Volts Units: 0.1 VAC	
		007	[Output Power] Output power present at T1, T2 & T3 (U, V & W).	Default: Read Only Min/Max: 0.0/Drive Rated kW × 2 Units: 0.1 kW	
		008	[Output Powr Fctr] Output power factor.	Default: Read Only Min/Max: 0.00/1.00 Units: 0.01	
		009	[Elapsed MWh]  Accumulated output energy of the drive.	Default: Read Only Min/Max: 0.0/214748352.0 MWh Units: 0.1 MWh	
010	[Elapsed Run Time]  Accumulated time drive is outputting power.	Default: Read Only Min/Max: 0.0/214748352.0 Hrs Units: 0.1 Hrs			

File	Group	No.	Parameter Name & Description <i>See page 1-2 for symbol descriptions</i>	Values	Related
MONITOR	Metering	011	Standard [MOP Frequency] Value of the signal at MOP (Motor Operated Potentiometer).	Default: Read Only Min/Max: -/+ [Maximum Freq] Units: 0.1 Hz	079
			Vector [MOP Reference] See description above.	Default: Read Only Min/Max: -/+ [Maximum Speed] Units: 0.1 Hz 0.1 RPM	
		012	[DC Bus Voltage] Present DC bus voltage level.	Default: Read Only Min/Max: 0.0/Based on Drive Rating Units: 0.1 VDC	
		013	[DC Bus Memory] 6 minute average of DC bus voltage level.	Default: Read Only Min/Max: 0.0/Based on Drive Rating Units: 0.1 VDC	
		014	Vector v3 [Elapsed kWh] Accumulated output energy of the drive.	Default: Read Only Min/Max: 0.0/429496729.5 kWh Units: 0.1 kWh	
		016	[Analog In1 Value]	Default: Read Only	
		017	[Analog In2 Value] Value of the signal at the analog inputs.	Min/Max: 0.000/20.000 mA -/+10.000V Units: 0.001 mA 0.001 Volt	
		022	Vector [Ramped Speed] Value of commanded speed after Accel/Decel, and S-Curve are applied.	Default: Read Only Min/Max: -/+400.0 Hz -/+24000.0 RPM Units: 0.1 Hz 0.1 RPM	079
		023	Vector [Speed Reference] Summed value of ramped speed, process PI and droop. When FVC Vector mode is selected, droop will not be added.	Default: Read Only Min/Max: -/+400.0 Hz -/+24000.0 RPM Units: 0.1 Hz 0.1 RPM	079
		024	Vector [Commanded Torque] FV Final torque reference value after limits and filtering are applied. Percent of motor rated torque.	Default: Read Only Min/Max: -/+800.0% Units: 0.1%	053
025	Vector [Speed Feedback] Displays the lightly filtered value of the actual motor speed, whether measured by encoder feedback, or estimated.	Default: Read Only Min/Max: -/+400.0 Hz -/+24000.0 RPM Units: 0.1 Hz 0.1 RPM			





File	Group	No.	Parameter Name & Description <i>See page 1-2 for symbol descriptions</i>	Values	Related
MONITOR	Drive Data	026	[Rated kW] Drive power rating.	Default: Read Only Min/Max: 0.00/3000.00 kW Units: 0.01 kW	
		027	[Rated Volts] The drive input voltage class (208, 240, 400 etc.).	Default: Read Only Min/Max: 0.0/6553.5 VAC 0.0/65535.0 VAC Vector Units: 0.1 VAC	
		028	[Rated Amps] The drive rated output current.	Default: Read Only Min/Max: 0.0/6553.5 Amps 0.0/65535.0 Amps Vector Units: 0.1 Amps	
		029	[Control SW Ver] Main Control Board software version.	Default: Read Only Min/Max: 0.000/256.256 0.000/65535.000 Vector Units: 0.001	196



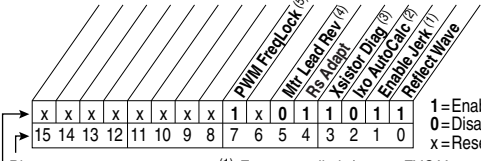





Motor Control File

File	Group	No.	Parameter Name & Description <i>See page 1-2 for symbol descriptions</i>	Values	Related
MOTOR CONTROL	Motor Data	040	[Motor Type] Set to match the type of motor connected. (1) Important: Selecting option 1 or 2 also requires selection of "Custom V/Hz," option 2 in parameter 53.	Default: 0 "Induction" Options: 0 "Induction" 1 "Synchr Reluc" ⁽¹⁾ 2 "Synchr PM" ⁽¹⁾	053
		041	[Motor NP Volts] Set to the motor nameplate rated volts.	Default: Based on Drive Rating Min/Max: 0.0/[Rated Volts] Units: 0.1 VAC	
		042	[Motor NP FLA] Set to the motor nameplate rated full load amps.	Default: Based on Drive Rating Min/Max: 0.0/[Rated Amps] × 2 Units: 0.1 Amps	047 048
		043	[Motor NP Hertz] Set to the motor nameplate rated frequency.	Default: Based on Drive Cat. No. Min/Max: 5.0/400.0 Hz Units: 0.1 Hz	
		044	[Motor NP RPM] Set to the motor nameplate rated RPM.	Default: 1750 RPM 1750.0 RPM Vector Min/Max: 60/2400 RPM 60.0/24000.0 RPM Vector Units: 1 RPM 1.0 RPM Vector	



File	Group	No.	Parameter Name & Description <i>See page 1-2 for symbol descriptions</i>	Values	Related
MOTOR CONTROL	Motor Data	045	[Motor NP Power] Set to the motor nameplate rated power.  	Default: Based on Drive Rating Min/Max: 0.00/100.00 Units: 0.00/1000.00 Vector 0.01 kW/HP See [Mtr NP Pwr Units]	046
		046	Standard [Mtr NP Pwr Units]  Selects the motor power units to be used.	Default: Drive Rating Based Options: 0 "Horsepower" 1 "kiloWatts"	
			Vector [Mtr NP Pwr Units] Selects the motor power units to be used. "Convert HP" = converts all power units to Horsepower. "Convert kW" = converts all power units to kilowatts.	Default: Drive Rating Based Options: 0 "Horsepower" 1 "kiloWatts" 2 "Convert HP" 3 "Convert kW"	
		047	[Motor OL Hertz]  Selects the output frequency below which the motor operating current is derated. The motor thermal overload will generate a fault at lower levels of current.	Default: Motor NP Hz/3 Min/Max: 0.0/Motor NP Hz Units: 0.1 Hz	042 220 
		048	[Motor OL Factor]  Sets the operating level for the motor overload. $\text{Motor FLA} \times \text{OL Factor} = \text{Operating Level}$	Default: 1.00 Min/Max: 0.20/2.00 Units: 0.01	042 220 
		049	Vector [Motor Poles]  Defines the number of poles in the motor.	Default: 4 Min/Max: 2/40 Units: 1 Pole	
	Torq Attributes	053	Standard [Torque Perf Mode]  Sets the method of motor torque production.	Default: 0 "Sensrls Vect" Options: 0 "Sensrls Vect" 1 "SV Economize" 2 "Custom V/Hz" 3 "Fan/Pmp V/Hz"	
			Vector [Motor Cntl Sel] Sets the method of motor control used in the drive. Important: "FVC Vector" mode requires autotuning of the motor, both coupled and uncoupled to the load.	Default: 0 "Sensrls Vect" Options: 0 "Sensrls Vect" 1 "SV Economize" 2 "Custom V/Hz" 3 "Fan/Pmp V/Hz" 4 "FVC Vector"	
		054	[Maximum Voltage] Sets the highest voltage the drive will output.	Default: Drive Rated Volts Min/Max: Rated Volts x 0.25/Rated Volts Units: 0.1 VAC	





File	Group	No.	Parameter Name & Description <i>See page 1-2 for symbol descriptions</i>	Values	Related
MOTOR CONTROL Torq Attributes		055	[Maximum Freq]  Sets the highest frequency the drive will output. Refer to [Overspeed Limit], 083.	Default: 110.0 or 130.0 Hz Min/Max: 5.0/420.0 Hz Units: 0.1 Hz	083
		056	[Compensation] Enables/disables correction options.  Factory Default Bit Values	<p>(1) For current limit (except FVC Vector mode). (2) Standard Control Option Only. (3) Vector Control Option Only. (4) Vector firmware 2.003 & later. (5) Vector firmware 3.001 & later.</p> <p>Option Descriptions</p> <p>Reflect Wave Disables reflected wave overvoltage protection for long cable lengths. (typically enabled). Enable Jerk In non-FVC Vector modes, disabling jerk removes a short S-curve at the start of the accel/decel ramp. Ixo AutoCalc Not functional – reserved for future enhancements. Xsistor Diag Disables power transistor power diagnostic tests which run at each start command. Rs Adapt FVC w/Encoder Only - Disabling may improve torque regulation at lower speeds (typically not needed). Mtr Lead Rev Reverses the phase rotation of the applied voltage, effectively reversing the motor leads. PWM Freq Lock Keeps the PWM frequency from decreasing to 2 kHz at low operating frequencies in FVC Vector mode without encoder.</p>	
		057	[Flux Up Mode] Auto = Flux is established for a calculated time period based on motor nameplate data. [Flux Up Time] is not used. Manual = Flux is established for [Flux Up Time] before acceleration.	Default: 0 "Manual" Options: 0 "Manual" 1 "Automatic"	053 058
		058	[Flux Up Time] Sets the amount of time the drive will use to try and achieve full motor stator flux. When a Start command is issued, DC current at current limit level is used to build stator flux before accelerating.	Default: 0.00 Secs 0.0 Secs Vector Min/Max: 0.00/5.00 Secs 0.0/5.0 Secs Vector 0.000/5.000 Secs v3 Units: 0.01 Secs 0.1 Secs Vector 0.001 Secs v3	053 058
		059	[SV Boost Filter] Sets the amount of filtering used to boost voltage during Sensorless Vector and FVC Vector (encoderless) operation.	Default: 500 Min/Max: 0/32767 Units: 1	

File	Group	No.	Parameter Name & Description <i>See page 1-2 for symbol descriptions</i>	Values	Related	
MOTOR CONTROL	Torq Attributes	061 	[Autotune] Provides a manual or automatic method for setting [IR Voltage Drop], [Flux Current Ref] and [Ixo Voltage Drop]. Valid only when parameter 53 is set to "Sensrls Vect," "SV Economize" or "FVC Vector."	Default: 3 "Calculate" Options: 0 "Ready" 1 "Static Tune" 2 "Rotate Tune" 3 "Calculate"	053 062	
		"Ready" (0) = Parameter returns to this setting following a "Static Tune" or "Rotate Tune." It also permits manually setting [IR Voltage Drop], [Ixo Voltage Drop] and [Flux Current Ref].				
		"Static Tune" (1) = A temporary command that initiates a non-rotational motor stator resistance test for the best possible automatic setting of [IR Voltage Drop] in all valid modes and a non-rotational motor leakage inductance test for the best possible automatic setting of [Ixo Voltage Drop] in "FVC Vector" mode. A start command is required following initiation of this setting. The parameter returns to "Ready" (0) following the test, at which time another start transition is required to operate the drive in normal mode. Used when motor cannot be rotated.				
		"Rotate Tune" (2) = A temporary command that initiates a "Static Tune" followed by a rotational test for the best possible automatic setting of [Flux Current Ref]. In "FVC Vector" mode, with encoder feedback, a test for the best possible automatic setting of [Slip RPM @ FLA] is also run. A start command is required following initiation of this setting. The parameter returns to "Ready" (0) following the test, at which time another start transition is required to operate the drive in normal mode. Important: Used when motor is uncoupled from the load. Results may not be valid if a load is coupled to the motor during this procedure.				
 ATTENTION: Rotation of the motor in an undesired direction can occur during this procedure. To guard against possible injury and/or equipment damage, it is recommended that the motor be disconnected from the load before proceeding.						
"Calculate" (3) = This setting uses motor nameplate data to automatically set [IR Voltage Drop], [Ixo Voltage Drop], [Flux Current Ref] and [Slip RPM @ FLA].						
		062	[IR Voltage Drop] Value of voltage drop across the resistance of the motor stator at rated motor current. Used only when parameter 53 is set to "Sensrls Vect," "SV Economize" or "FVC Vector."	Default: Based on Drive Rating Min/Max: 0.0/[Motor NP Volts]× 0.25 Units: 0.1 VAC	053 061	
		063 	[Flux Current Ref] Value of amps for full motor flux. Used only when parameter 53 is set to "Sensrls Vect," "SV Economize" or "FVC Vector."	Default: Based on Drive Rating Min/Max: 0.00/[Motor NP FLA] Units: 0.01 Amps	053 061	
		064 	[Ixo Voltage Drop] Value of voltage drop across the leakage inductance of the motor at rated motor current. Used only when parameter 53 is set to "Sensrls Vect," "SV Economize" or "FVC Vector."	Default: Based on Drive Rating Min/Max: 0.0/230.0, 480.0, 575 VAC Units: 0.1 VAC		

File	Group	No.	Parameter Name & Description <i>See page 1-2 for symbol descriptions</i>	Values	Related
MOTOR CONTROL	Torq Attributes	066	Vector [Autotune Torque]  Specifies motor torque applied to the motor during the flux current and inertia tests performed during an autotune. 	Default: 50.0% Min/Max: 0.0/150.0% Units: 0.1%	053
		067	Vector [Inertia Autotune]  Provides an automatic method of setting [Total Inertia]. This test is automatically run during Start-Up motor tests.  Important: Use when motor is coupled to the load. Results may not be valid if the load is not coupled to the motor during this procedure. "Ready" = Parameter returns to this setting following a completed inertia tune. "Inertia Tune" = A temporary command that initiates an inertia test of the motor/load combination. The motor will ramp up and down, while the drive measures the amount of inertia.	Default: 0 "Ready" Options: 0 "Ready" 1 "Inertia Tune"	053 450
		427	Vector [Torque Ref A Sel]	Default: 1 "Torque Setpt"	053
		431	Vector [Torque Ref B Sel]  Selects the source of the external torque reference to the drive. How this reference is used is dependent upon [Speed/Torque Mod]. (1) See <i>Appendix B</i> for DPI port locations. (2) Vector firmware 3.001 and later.	Options: 0 "Torque Setpt" "Torque Stp1" ⁽²⁾ 1 "Analog In 1" 2 "Analog In 2" 3-17 "Reserved" 18-22 "DPI Port 1-5" ⁽¹⁾ 23 "Reserved" 24 "Disabled" 25-28 "Scale Block1-4" ⁽²⁾ 29 "Torque Stp2" ⁽²⁾	
		428	Vector [Torque Ref A Hi]	Default: 100.0%	053
		432	Vector [Torque Ref B Hi]  Scales the upper value of the [Torque Ref A Sel] selection when the source is an analog input.	Min/Max: -/+800.0% Units: 0.1%	
		429	Vector [Torque Ref A Lo]	Default: 0.0%	053
		433	Vector [Torque Ref B Lo]  Scales the lower value of the [Torque Ref A Sel] selection when the source is an analog input.	Min/Max: -/+800.0% Units: 0.1%	
		430	Vector [Torq Ref A Div]  Defines the value of the divisor for the [Torque Ref A Sel] selection.	Default: 1.0 Min/Max: 0.1/3276.7 Units: 0.1	053
		434	Vector [Torque Ref B Mult]  Defines the value of the multiplier for the [Torque Ref B Sel] selection.	Default: 1.0 Min/Max: -/+32767.0 Units: 0.1	053

File	Group	No.	Parameter Name & Description <i>See page 1-2 for symbol descriptions</i>	Values	Related																																																																						
MOTOR CONTROL	Torq Attributes	435	Vector [Torque Setpoint] Vector v3 [Torque Setpoint] Provides an internal fixed value for Torque Setpoint when [Torque Ref Sel] is set to "Torque Setpt."	Default: 0.0% Min/Max: -/+800.0% Units: 0.1%	053																																																																						
		436	Vector [Pos Torque Limit] Defines the torque limit for the positive torque reference value. The reference will not be allowed to exceed this value.	Default: 200.0% Min/Max: 0.0/800.0% Units: 0.1%	053																																																																						
		437	Vector [Neg Torque Limit] Defines the torque limit for the negative torque reference value. The reference will not be allowed to exceed this value.	Default: -200.0% Min/Max: -800.0/0.0% Units: 0.1%	053																																																																						
		438	Vector v3 [Torque Setpoint2] Provides an internal fixed value for Torque Setpoint when [Torque Ref Sel] is set to "Torque Setpt 2."	Default: 0.0% Min/Max: -/+800.0% Units: 0.1%																																																																							
		440	Vector [Control Status] Displays a summary status of any condition that may be limiting either the current or the torque reference.	Read Only	053																																																																						
			<table border="1" style="margin-left: auto; margin-right: auto;"> <tr> <td>Vll Lim Ckag</td><td>Obsvrv Cts</td><td>Fld TqLstS</td><td>Tqg Ref</td><td>Ve TrqPr</td><td>Min Trq Cur Lim</td><td>Max Slip Lim</td><td>Pos Slip Lim</td><td>Pos Wr Trq Lim</td><td>Neg Wr Trq Lim</td><td>Pos Trq Limit</td><td>Neg Trq Limit</td><td>Pos Trq Cur Lim</td><td>Neg Trq Cur Lim</td> </tr> <tr> <td>0</td><td>0</td><td>0</td><td>0</td><td>0</td><td>0</td><td>0</td><td>0</td><td>0</td><td>0</td><td>0</td><td>0</td><td>0</td><td>0</td> </tr> <tr> <td>15</td><td>14</td><td>13</td><td>12</td><td>11</td><td>10</td><td>9</td><td>8</td><td>7</td><td>6</td><td>5</td><td>4</td><td>3</td><td>2</td><td>1</td><td>0</td> </tr> </table> <p>Bit #</p> <table border="1" style="margin-left: auto; margin-right: auto;"> <tr> <td>RephsMot</td><td>EconOpt</td><td>FltBznt</td><td>Drv Vll Lim</td><td>Vll LimStator</td> </tr> <tr> <td>0</td><td>0</td><td>0</td><td>0</td><td>0</td> </tr> <tr> <td>31</td><td>30</td><td>29</td><td>28</td><td>27</td><td>26</td><td>25</td><td>24</td><td>23</td><td>22</td><td>21</td><td>20</td><td>19</td><td>18</td><td>17</td><td>16</td> </tr> </table> <p>Bit #</p> <p>1 = Condition True 0 = Condition False x = Reserved</p>	Vll Lim Ckag	Obsvrv Cts	Fld TqLstS	Tqg Ref	Ve TrqPr	Min Trq Cur Lim	Max Slip Lim	Pos Slip Lim	Pos Wr Trq Lim	Neg Wr Trq Lim	Pos Trq Limit	Neg Trq Limit	Pos Trq Cur Lim	Neg Trq Cur Lim	0	0	0	0	0	0	0	0	0	0	0	0	0	0	15	14	13	12	11	10	9	8	7	6	5	4	3	2	1	0	RephsMot	EconOpt	FltBznt	Drv Vll Lim	Vll LimStator	0	0	0	0	0	31	30	29	28	27	26	25	24	23	22	21	20	19	18	17	16		
Vll Lim Ckag	Obsvrv Cts	Fld TqLstS	Tqg Ref	Ve TrqPr	Min Trq Cur Lim	Max Slip Lim	Pos Slip Lim	Pos Wr Trq Lim	Neg Wr Trq Lim	Pos Trq Limit	Neg Trq Limit	Pos Trq Cur Lim	Neg Trq Cur Lim																																																														
0	0	0	0	0	0	0	0	0	0	0	0	0	0																																																														
15	14	13	12	11	10	9	8	7	6	5	4	3	2	1	0																																																												
RephsMot	EconOpt	FltBznt	Drv Vll Lim	Vll LimStator																																																																							
0	0	0	0	0																																																																							
31	30	29	28	27	26	25	24	23	22	21	20	19	18	17	16																																																												
		441	Vector [Mtr Tor Cur Ref] Displays the torque current reference value that is present at the output of the current rate limiter (parameter 154).	Default: Read Only Min/Max: -/+32767.0 Amps Units: 0.01 Amps	053																																																																						
Volts per Hertz		069	[Start/Acc Boost] Sets the voltage boost level for starting and acceleration when "Custom V/Hz" mode is selected. Refer to parameter 083 [Overspeed Limit].	Default: Based on Drive Rating Min/Max: 0.0/[Motor NP Volts] x 0.25 Units: 0.1 VAC	053 070																																																																						
		070	[Run Boost] Sets the boost level for steady state or deceleration when "Fan/Pmp V/Hz" or "Custom V/Hz" modes are selected. See parameter 083 [Overspeed Limit].	Default: Based on Drive Rating Min/Max: 0.0/[Motor NP Volts] x 0.25 Units: 0.1 VAC	053 069																																																																						

File	Group	No.	Parameter Name & Description <i>See page 1-2 for symbol descriptions</i>	Values	Related
MOTOR CONTROL	Volts per Hertz	071	[Break Voltage] Sets the voltage the drive will output at [Break Frequency]. Refer to parameter 083 [Overspeed Limit].	Default: [Motor NP Volts] × 0.25 Min/Max: 0.0/[Motor NP Volts] Units: 0.1 VAC	053 072
		072	[Break Frequency] Sets the frequency the drive will output at [Break Voltage]. Refer to parameter 083.	Default: [Motor NP Hz] × 0.25 Min/Max: 0.0/[Maximum Freq] Units: 0.1 Hz	053 071
	Speed Feedback	412	Vector [Motor Fdbk Type] Selects the encoder type; single channel or quadrature. Options 1 & 3 detect a loss of encoder signal (when using differential inputs) regardless of the [Feedback Select], param. 080 setting. For FVC Vector mode, use a quadrature encoder only (option 0/1). If a single channel encoder is used (option 2/3) in sensorless vector or V/Hz mode, select "Reverse Dis" (option 2) in param. 190.	Default: 0 "Quadrature" Options: 0 "Quadrature" 1 "Quad Check" 2 "Single Chan" 3 "Single Check"	
		413	Vector [Encoder PPR]  Contains the encoder pulses per revolution. For improved operation in FVC Vector mode, PPR should be ≥ (64 x motor poles).	Default: 1024 PPR Min/Max: 2/20000 PPR Units: 1 PPR	
		414	Vector [Enc Position Fdbk] Displays raw encoder pulse count. For single channel encoders, this count will increase (per rev.) by the amount in [Encoder PPR]. For quadrature encoders this count will increase by 4 times the amount defined in [Encoder PPR].	Default: Read Only Min/Max: -/+2147483647 Units: 1	
		415	Vector [Encoder Speed] Provides a monitoring point that reflects speed as seen from the feedback device.	Default: Read Only Min/Max: -/+420.0 Hz -/+25200.0 RPM Units: 0.1 Hz 0.1 RPM	079
		416	Vector [Fdbk Filter Sel] Selects the type of feedback filter desired. "Light" uses a 35/49 radian feedback filter. "Heavy" uses a 20/40 radian feedback filter.	Default: 0 "None" Options: 0 "None" 1 "Light" 2 "Heavy"	
		419	Vector [Notch Filter Freq]  Sets the center frequency for an optional 2-pole notch filter. Filter is applied to the torque command. "0" disables this filter.	Default: 0.0 Hz Min/Max: 0.0/500.0 Hz Units: 0.1 Hz	053

File	Group	No.	Parameter Name & Description <i>See page 1-2 for symbol descriptions</i>	Values	Related
MOTOR CONTROL	Speed Feedback	420	Vector [Notch Filter K]  Sets the gain for the 2-pole notch filter.	Default: 0.3 Hz Min/Max: 0.1/0.9 Hz Units: 0.1 Hz	053
		421	Vector [Marker Pulse]  Latches the raw encoder count at each marker pulse.	Default: Read Only Min/Max: -/+2147483647 Units: 1	
		422	Vector [Pulse In Scale]  Sets the scale factor/gain for the Pulse Input when P423 is set to "Pulse Input." Calculate for the desired speed command as follows: for Hz, [Pulse In Scale] = $\frac{\text{Input Pulse Rate (Hz)}}{\text{Desired Cmd. (Hz)}}$ for RPM, [Pulse In Scale] = $\frac{\text{Input Pulse Rate (Hz)}}{\text{Desired Cmd. (RPM)}} \times \frac{120}{[\text{Motor Poles}]}$	Default: 64 Min/Max: 2/20000 Units: 1	
		423	Vector [Encoder Z Chan]  Defines if the input wired to terminals 5 & 6 of the Encoder Terminal Block will be used as a Pulse or Marker input. Options 1 & 3 detect a loss of signal (when using differential inputs) regardless of the [Feedback Select], param. 080 setting.	Default: 0 "Pulse Input" Options: 0 "Pulse Input" 1 "Pulse Check" 2 "Marker Input" 3 "Marker Check"	

Speed Command File

File	Group	No.	Parameter Name & Description <i>See page 1-2 for symbol descriptions</i>	Values	Related
SPEED COMMAND	Spd Mode & Limits	079	Vector [Speed Units]  Selects the units to be used for all speed related parameters. Options 0 & 1 indicate status only. Options 2 & 3 will convert/configure the drive for that selection. "Convert Hz" (2) - converts all speed based parameters to Hz, and changes the value proportionately (i.e. 1800 RPM = 60 Hz). "Convert RPM" (3) - converts all speed based parameters to RPM, and changes the value proportionately.	Default: 0 "Hz" Options: 0 "Hz" 1 "RPM" 2 "Convert Hz" 3 "Convert RPM"	





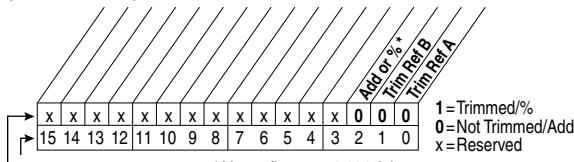

File	Group	No.	Parameter Name & Description <i>See page 1-2 for symbol descriptions</i>	Values	Related
SPEED COMMAND	Spd Mode & Limits	080	<p>Standard [Speed Mode]</p> <p> Sets the method of speed regulation.</p>	Default: 0 "Open Loop" Options: 0 "Open Loop" 1 "Slip Comp" 2 "Process PI"	412 152
			<p>Vector [Feedback Select]</p> <p>Selects the source for motor speed feedback. Note that all selections are available when using Process PI. "Open Loop" (0) - no encoder is present, and slip compensation is not needed. "Slip Comp" (1) - tight speed control is needed, and encoder is not present. "Encoder" (3) - an encoder is present. "Simulator" (5) - Simulates a motor for testing drive operation & interface check.</p>	Default: 0 "Open Loop" Options: 0 "Open Loop" 1 "Slip Comp" 2 "Reserved" 3 "Encoder" 4 "Reserved" 5 "Simulator"	
		081	<p>[Minimum Speed]</p> <p> Sets the low limit for speed reference after scaling is applied. Refer to parameter 083 [Overspeed Limit].</p>	Default: 0.0 Min/Max: 0.0/[Maximum Speed] Units: 0.1 Hz 0.1 RPM Vector	079 083 092 095
		082	<p>[Maximum Speed]</p> <p> Sets the high limit for speed reference after scaling is applied. Refer to parameter 083 [Overspeed Limit].</p>	Default: 50.0 or 60.0 Hz (volt class) [Motor NP RPM] Min/Max: 5.0/400.0 Hz 75.0/24000.0 RPM Vector Units: 0.1 Hz 0.1 RPM Vector	055 079 083 091 094 202
		083	<p>[Overspeed Limit]</p> <p> Sets the incremental amount of the output frequency (above [Maximum Speed]) allowable for functions such as slip compensation. [Maximum Speed] + [Overspeed Limit] must be \leq [Maximum Freq]</p>	Default: 10.0 Hz 300.0 RPM Vector Min/Max: 0.0/20.0 Hz 0.0/600.0 RPM Vector Units: 0.1 Hz 0.1 RPM Vector	055 079 082
<p>The graph plots Voltage on the y-axis against Frequency on the x-axis. Key points and ranges are marked: <ul style="list-style-type: none"> Start Boost: The initial linear portion of the speed curve. Break Frequency: The frequency at which the motor's speed begins to rise more steeply. Motor Hz: The base frequency of the motor. Max Speed: The maximum speed of the motor. Output Freq Limit: The maximum frequency the drive can output. Max Freq: The absolute maximum frequency. Frequency Trim due to Speed Control Mode: A small frequency range at the start of the speed curve. Overspeed Limit: The frequency range above the maximum speed where the drive can still operate. Allowable Output Frequency Range (Bus Regulation or Current Limit): The range of frequencies where the drive can maintain constant output voltage. Allowable Output Frequency Range (Normal Operation): The range of frequencies where the drive can maintain constant output current. Allowable Reference Frequency Range: The range of reference frequencies that the drive can accept. </p>					

File	Group	No.	Parameter Name & Description <i>See page 1-2 for symbol descriptions</i>	Values	Related
SPEED COMMAND	Spd Mode & Limits	084	[Skip Frequency 1]	Default: 0.0 Hz	087
		085	[Skip Frequency 2]	Default: 0.0 Hz	i
		086	[Skip Frequency 3]	Default: 0.0 Hz	
		Sets a frequency at which the drive will not operate. [Skip Frequency 1-3] and [Skip Frequency Band] must not equal 0.		Min/Max: -/[Maximum Speed] Units: 0.1 Hz	
		087	[Skip Freq Band]	Default: 0.0 Hz Min/Max: 0.0/30.0 Hz Units: 0.1 Hz	084 085 086
		088	Vector [Speed/Torque Mod] FV Selects the torque reference source. "Zero Torque" (0) - torque command = 0. "Speed Reg" (1) - drive operates as a speed regulator. "Torque Reg" (2) - an external torque reference is used for the torque command. "Min Torq/Spd" (3) - selects the smallest algebraic value to regulate to when the torque reference and torque generated from the speed regulator are compared. "Max Torq/Spd" (4) - selects the largest algebraic value when the torque reference and the torque generated from the speed regulator are compared. "Sum Torq/Spd" (5) - selects the sum of the torque reference and the torque generated from the speed regulator. "Absolute" (6) - selects the smallest absolute algebraic value to regulate to when the torque reference and torque generated from the speed regulator are compared.	Default: 1 "Speed Reg" Options: 0 "Zero Torque" 1 "Speed Reg" 2 "Torque Reg" 3 "Min Torq/Spd" 4 "Max Torq/Spd" 5 "Sum Torq/Spd" 6 "Absolute Min"	053
		454	Vector [Rev Speed Limit] FV Sets a limit on speed in the negative direction, when in FVC Vector mode. Used in bipolar mode only. A value of zero disables this parameter and uses [Maximum Speed] for reverse speed limit.	Default: 0.0 RPM Min/Max: -[Max Speed]/0.0 Hz -[Max Speed]/0.0 RPM Units: 0.0 Hz 0.0 RPM	i

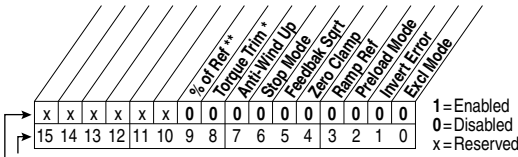

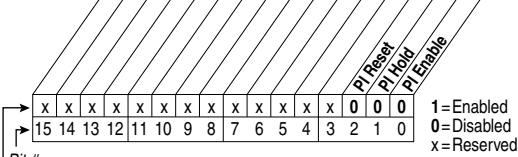
File	Group	No.	Parameter Name & Description <i>See page 1-2 for symbol descriptions</i>	Values	Related
SPEED COMMAND	Speed Reference	090	[Speed Ref A Sel] Selects the source of the speed reference to the drive unless [Speed Ref B Sel] or [Preset Speed 1-7] is selected. (1) See Appendix B for DPI port locations. (2) Vector firmware 3.001 and later.	Default: 2 "Analog In 2" Options: 1 "Analog In 1" 2 "Analog In 2" 3-6 "Reserved" 7 "Pulse In" 8 "Encoder" 9 "MOP Level" 10 "Reserved" 11 "Preset Spd1" 12 "Preset Spd2" 13 "Preset Spd3" 14 "Preset Spd4" 15 "Preset Spd5" 16 "Preset Spd6" 17 "Preset Spd7" 18 "DPI Port 1" ⁽¹⁾ 19 "DPI Port 2" ⁽¹⁾ 20 "DPI Port 3" ⁽¹⁾ 21 "DPI Port 4" ⁽¹⁾ 22 "DPI Port 5" ⁽¹⁾ 23-24 "Reserved" 25 "Scale Block1" ⁽²⁾ 26 "Scale Block2" ⁽²⁾ 27 "Scale Block3" ⁽²⁾ 28 "Scale Block4" ⁽²⁾	002 091 thru 093 101 thru 107 117 thru 120 192 thru 194 213 272 273 320 361 thru 366
		091	[Speed Ref A Hi] Scales the upper value of the [Speed Ref A Sel] selection when the source is an analog input.	Default: [Maximum Speed] Min/Max: -/[Maximum Speed] Units: 0.1 Hz 0.01 RPM Vector	079 082
		092	[Speed Ref A Lo] Scales the lower value of the [Speed Ref A Sel] selection when the source is an analog input.	Default: 0.0 Min/Max: -/[Maximum Speed] Units: 0.1 Hz 0.01 RPM Vector	079 081
		093	[Speed Ref B Sel] See [Speed Ref A Sel] .	Default: 11 "Preset Spd1" Options: See [Speed Ref A Sel]	See 090
		094	[Speed Ref B Hi] Scales the upper value of the [Speed Ref B Sel] selection when the source is an analog input.	Default: [Maximum Speed] Min/Max: -/[Maximum Speed] Units: 0.1 Hz 0.01 RPM Vector	079 093
		095	[Speed Ref B Lo] Scales the lower value of the [Speed Ref B Sel] selection when the source is an analog input.	Default: 0.0 Min/Max: -/[Maximum Speed] Units: 0.1 Hz 0.01 RPM Vector	079 090 093

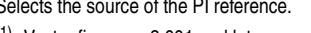
File	Group	No.	Parameter Name & Description <i>See page 1-2 for symbol descriptions</i>	Values	Related
SPEED COMMAND	Speed Reference	096	[TB Man Ref Sel]  Sets the manual speed reference source when a digital input is configured for "Auto/Manual." (1) "Analog In 2" is not a valid selection if it was selected for any of the following: - [Trim In Select] - [PI Feedback Sel] - [PI Reference Sel] - [Current Lmt Sel] - [Sleep-Wake Ref]	Default: 1 "Analog In 1" Options: 1 "Analog In 1" 2 "Analog In 2" ⁽¹⁾ 3-8 "Reserved" 9 "MOP Level"	097 098
		097	[TB Man Ref Hi] Scales the upper value of the [TB Man Ref Sel] selection when the source is an analog input.	Default: [Maximum Speed] Min/Max: -/[Maximum Speed] Units: 0.1 Hz 0.01 RPM Vector	079 096
		098	[TB Man Ref Lo] Scales the lower value of the [TB Man Ref Sel] selection when the source is an analog input.	Default: 0.0 Min/Max: -/[Maximum Speed] Units: 0.1 Hz 0.01 RPM Vector	079 096
		099	Vector [Pulse Input Ref] Displays the pulse input value as seen at terminals 5 and 6 of the Encoder Terminal Block, if [Encoder Z Chan], parameter 423 is set to "Pulse Input."	Default: Read Only Min/Max: -/+420.0 Hz -/+25200.0 RPM Units: 0.1 Hz 0.1 RPM	
	100	Standard [Jog Speed] Sets the output frequency when a jog command is issued.	Default: 10.0 Hz Min/Max: -/[Maximum Speed] Units: 0.1 Hz	079	
		Vector [Jog Speed 1] Sets the output frequency when Jog Speed 1 is selected.	Default: 10.0 Hz 300.0 RPM Min/Max: -/[Maximum Speed] Units: 0.1 Hz 1 RPM		
	Discrete Speeds	101	[Preset Speed 1]	Default: 5.0 Hz/150 RPM Vector 10.0 Hz/300 RPM Vector 20.0 Hz/600 RPM Vector 30.0 Hz/900 RPM Vector 40.0 Hz/1200 RPM Vector 50.0 Hz/1500 RPM Vector 60.0 Hz/1800 RPM Vector Min/Max: -/[Maximum Speed] Units: 0.1 Hz 1 RPM Vector	079 090 093
		102	[Preset Speed 2]		
		103	[Preset Speed 3]		
		104	[Preset Speed 4]		
105		[Preset Speed 5]			
106		[Preset Speed 6]			
107		[Preset Speed 7] Provides an internal fixed speed command value. In bipolar mode direction is commanded by the sign of the reference.			
108	Vector [Jog Speed 2] Sets the output frequency when Jog Speed 2 is selected.	Default: 10.0 Hz 300.0 RPM Min/Max: -/[Maximum Speed] Units: 0.1 Hz 1 RPM			

File	Group	No.	Parameter Name & Description <i>See page 1-2 for symbol descriptions</i>	Values	Related
SPEED COMMAND	Speed Trim	116	Vector v3 [Trim % Setpoint] Adds or subtracts a percentage of the speed reference or maximum speed. Dependent on the setting of [Trim Out Select], parameter 118.	Default: 0.0% Min/Max: -/+200.0% Units: 0.1%	118
		117	[Trim In Select] Specifies which analog input signal is being used as a trim input.	Default: 2 "Analog In 2" Options: See [Speed Ref A Sel]	090 093
		118	[Trim Out Select] Specifies which speed references are to be trimmed. 	117 119 120	
		119	[Trim Hi] Scales the upper value of the [Trim In Select] selection when the source is an analog input.	Default: 60.0 Hz Min/Max: -/+ [Maximum Speed] Units: 0.1 Hz 1 RPM/% Vector	079 082 117
		120	[Trim Lo] Scales the lower value of the [Trim In Select] selection when the source is an analog input.	Default: 0.0 Hz Min/Max: -/+ [Maximum Speed] Units: 0.1 Hz 1 RPM/% Vector	079 117
		Important: Parameters in the Slip Comp Group are used to enable and tune the Slip Compensation Regulator. In order to allow the regulator to control drive operation, parameter 080 [Speed Mode] must be set to 1 "Slip Comp".			
		121	[Slip RPM @ FLA] Sets the amount of compensation to drive output at motor FLA. If the value of parameter 061 [Autotune] = 3 "Calculate" changes made to this parameter will not be accepted. Value may be changed by [Autotune] when "Encoder" is selected in [Feedback Select], parameter 080.	Default: Based on [Motor NP RPM] Min/Max: 0.0/1200.0 RPM Units: 0.1 RPM	061 080 122 123
		122	[Slip Comp Gain] Sets the response time of slip compensation.	Default: 40.0 Min/Max: 1.0/100.0 Units: 0.1	080 121 122
		123	[Slip RPM Meter] Displays the present amount of adjustment being applied as slip compensation.	Default: Read Only Min/Max: -/+300.0 RPM Units: 0.1 RPM	080 121 122

File	Group	No.	Parameter Name & Description See page 1-2 for symbol descriptions	Values	Related
SPEED COMMAND	Process PI		<p>Important: Parameters in the Process PI Group are used to enable and tune the PI Loop. In order to allow the PI Loop to control drive operation, program the following:</p> <p>Standard Control Option – Parameter 080 [Speed Mode] must be set to 2 “Process PI” and parameter 125, bit 0 must be set to “1, Enabled.”</p> <p>Vector Control Option – Only requires setting parameter 125, bit 0 “1, Enabled.”</p>		
		124	<p>[PI Configuration]</p> <p> Sets configuration of the PI regulator.</p> <p>Legend: 1 = Enabled 0 = Disabled x = Reserved</p> <p>* Vector Control Option Only ** Vector firmware 3.001 & later</p> <p>Factory Default Bit Values</p>		124 thru 138 
		125	<p>[PI Control]</p> <p>Controls the PI regulator.</p> <p> Legend: 1 = Enabled 0 = Disabled x = Reserved</p> <p>Factory Default Bit Values</p>		080 
		126	<p>[PI Reference Sel]</p> <p> Selects the source of the PI reference. (1) Vector firmware 3.001 and later.</p>	<p>Default: 0 “PI Setpoint”</p> <p>Options:</p> <ul style="list-style-type: none"> 0 “PI Setpoint” 1 “Analog In 1” 2 “Analog In 2” 3-6 “Reserved” 7 “Pulse In” 8 “Encoder” 9 “MOP Level” 10 “Master Ref” 11-17 “Preset Spd1-7” 18-22 “DPI Port 1-5” 23-24 “Reserved” 25 “Scale Block 1”⁽¹⁾ 26 “Scale Block 2”⁽¹⁾ 27 “Scale Block 3”⁽¹⁾ 28 “Scale Block 4”⁽¹⁾ 	024 124 thru 138 
		127	<p>[PI Setpoint]</p> <p>Provides an internal fixed value for process setpoint when [PI Reference Sel] is set to “PI Setpoint.”</p>	<p>Default: 50.00%</p> <p>Min/Max: +/-100.00% of Maximum Process Value</p> <p>Units: 0.01%</p>	124 thru 138



File	Group	No.	Parameter Name & Description <i>See page 1-2 for symbol descriptions</i>	Values	Related
SPEED COMMAND	Process PI	128	[PI Feedback Sel] Selects the source of the PI feedback.	Default: 2 "Analog In 2" Options: See [PI Reference Sel] .	124 thru 138
		129	[PI Integral Time] Time required for the integral component to reach 100% of [PI Error Meter]. Not functional when the PI Hold bit of [PI Control] = "1" (enabled).	Default: 2.00 Secs Min/Max: 0.00/100.00 Secs Units: 0.01 Secs	124 thru 138
		130	[PI Prop Gain] Sets the value for the PI proportional component. PI Error x PI Prop Gain = PI Output	Default: 1.0 Min/Max: 0.00/100.00 Units: 0.01	124 thru 138
		131	[PI Lower Limit] Sets the lower limit of the PI output.	Default: -[Maximum Freq] -100% Vector Min/Max: -/+400.0 Hz -/+800.0% Vector Units: 0.1 Hz 0.1% Vector	079 124 thru 138
		132	[PI Upper Limit] Sets the upper limit of the PI output.	Default: +[Maximum Freq] 100% Vector Min/Max: -/+400.0 Hz -/+800.0% Vector Units: 0.1 Hz 0.1% Vector	079 124 thru 138
		133	[PI Preload] Sets the value used to preload the integral component on start or enable.	Default: 0.0 Hz 100.0% Vector Min/Max: [PI Lower Limit]/ [PI Upper Limit] Units: 0.1 Hz 0.1% Vector	079 124 thru 138
		134	[PI Status] Status of the Process PI regulator.	Read Only	124 thru 138
					<p>1 = Condition True 0 = Condition False x = Reserved</p>
135	[PI Ref Meter] Present value of the PI reference signal.	Default: Read Only Min/Max: -/+100.0% Units: 0.1%	124 thru 138		
136	[PI Fdback Meter] Present value of the PI feedback signal.	Default: Read Only Min/Max: -/+100.0% Units: 0.1%	124 thru 138		







File	Group	No.	Parameter Name & Description <i>See page 1-2 for symbol descriptions</i>	Values	Related
SPEED COMMAND	Process PI	137	[PI Error Meter] Present value of the PI error.	Default: Read Only Min/Max: $-/+100.0\%$ $-/+200.0\%$ v3 Units: 0.1%	124 thru 138
		138	[PI Output Meter] Present value of the PI output.	Default: Read Only Min/Max: $-/+100.0$ Hz $-/+100.0\%$ Vector $-/+800.0\%$ v3 Units: 0.1 Hz 0.1% Vector	124 thru 138
		139	Vector [PI BW Filter] <i>Firmware 2.001 & later</i> – Provides filter for Process PI error signal. The output of this filter is displayed in [PI Error Meter]. Zero will disable the filter.	Default: 0.0 Radians Min/Max: 0.0/240.0 Radians Units: 0.1 Radians	137
		459	Vector v3 [PI Deriv Time]  Refer to formula below: $PI_{Out} = KD \text{ (Sec)} \times \frac{d_{PI \text{ Error}} \text{ (\%)}}{d_t \text{ (Sec)}}$	Default: 0.00 Secs Min/Max: 0.00/100.00 Secs Units: 0.01 Secs	
		460	Vector [PI Reference Hi] Scales the upper value of [PI Reference Sel] of the source.	Default: 100.0% Min/Max: $-/+100.0\%$ Units: 0.1%	
		461	Vector [PI Reference Lo] Scales the lower value of [PI Reference Sel] of the source.	Default: -100.0% Min/Max: $-/+100.0\%$ Units: 0.1%	
		462	Vector [PI Feedback Hi] Scales the upper value of [PI Feedback] of the source.	Default: 100.0% Min/Max: $-/+100.0\%$ Units: 0.1%	
		463	Vector [PI Feedback Lo] Scales the lower value of [PI Feedback] of the source.	Default: 0.0% Min/Max: $-/+100.0\%$ Units: 0.1%	
		445	Vector [Ki Speed Loop]  Controls the integral error gain of the speed regulator. The drive automatically adjusts [Ki Speed Loop] when a non-zero value is entered for [Speed Desired BW] or an autotune is performed. Typically, manual adjustment of this parameter is needed only if system inertia cannot be determined through an autotune. [Speed Desired BW] is set to "0" when a manual adjustment is made to this parameter.	Default: 7.0 Min/Max: 0.0/4000.0 Units: 0.1	053
			Speed Regulator		



File	Group	No.	Parameter Name & Description <i>See page 1-2 for symbol descriptions</i>	Values	Related
SPEED COMMAND	Speed Regulator	446	Vector [Kp Speed Loop] FV Controls the proportional error gain of the speed regulator. The drive automatically adjusts [Kp Speed Loop] when a non-zero value is entered for [Speed Desired BW] or an auto-tune is performed. Typically, manual adjustment of this parameter is needed only if system inertia cannot be determined through an autotune. [Speed Desired BW] is set to "0" when a manual adjustment is made to this parameter.	Default: 6.3 Min/Max: 0.0/200.0 Units: 0.1	053
		447	Vector [Kf Speed Loop] FV Controls the feed forward gain of the speed regulator. Setting the Kf gain greater than zero reduces speed feedback overshoot in response to a step change in speed reference.	Default: 0.0 Min/Max: 0.0/0.5 Units: 0.1	053
		449	Vector [Speed Desired BW] FV Sets the speed loop bandwidth and determines the dynamic behavior of the speed loop. As bandwidth increases, the speed loop becomes more responsive and can track a faster changing speed reference. Adjusting this parameter will cause the drive to calculate and change [Ki Speed Loop] and [Kp Speed Loop] gains.	Default: 0.0 Radians/Sec Min/Max: 0.0/250.0 Radians/Sec Units: 0.1 Radians/Sec	053
		450	Vector [Total Inertia] FV Represents the time in seconds, for a motor coupled to a load to accelerate from zero to base speed, at rated motor torque. The drive calculates Total Inertia during the autotune inertia procedure. Adjusting this parameter will cause the drive to calculate and change [Ki Speed Loop] and [Kp Speed Loop] gains.	Default: 1.25 Secs 0.10 Secs v3 Min/Max: 0.1/600.0 Secs 0.01/600.00 v3 Units: 0.1 Secs 0.01 Secs v3	053
		451	Vector v3 [Speed Loop Meter] FV Value of the speed regulator output.	Default: Read Only Min/Max: -/+800.0%/Hz/RPM Units: 0.1%/Hz/RPM	053 121 079

Dynamic Control File



File	Group	No.	Parameter Name & Description <i>See page 1-2 for symbol descriptions</i>	Values	Related
DYNAMIC CONTROL	Ramp Rates	140	[Accel Time 1]	Default: 10.0 Secs	142 143 146 361
		141	[Accel Time 2] Sets the rate of accel for all speed increases. $\frac{\text{Max Speed}}{\text{Accel Time}} = \text{Accel Rate}$	10.0 Secs Min/Max: 0.1/3600.0 Secs 0.0/3600.0 Secs v3 Units: 0.1 Secs	
		142	[Decel Time 1]	Default: 10.0 Secs	
	143	[Decel Time 2] Sets the rate of decel for all speed decreases. $\frac{\text{Max Speed}}{\text{Decel Time}} = \text{Decel Rate}$	10.0 Secs Min/Max: 0.1/3600.0 Secs 0.0/3600.0 Secs v3 Units: 0.1 Secs	140 141 146 361	
	146	[S Curve %] Sets the percentage of accel or decel time that is applied to the ramp as S Curve. Time is added, 1/2 at the beginning and 1/2 at the end of the ramp.	Default: 0% Min/Max: 0/100% Units: 1%	140 thru 143	
	Load Limits	147	[Current Lmt Sel]  Selects the source for the adjustment of current limit (i.e. parameter, analog input, etc.).	Default: 0 "Cur Lim Val" Options: 0 "Cur Lim Val" 1 "Analog In 1" 2 "Analog In 2"	146 149
		148	[Current Lmt Val] Defines the current limit value when [Current Lmt Sel] = "Cur Lim Val."	Default: [Rated Amps] × 1.5 (Equation yields approximate default value.) Min/Max: Based on Drive Rating Units: 0.1 Amps	147 149
		149	[Current Lmt Gain] Sets the responsiveness of the current limit.	Default: 250 Min/Max: 0/5000 Units: 1	147 148
		150	[Drive OL Mode] Selects the drive's response to increasing drive temperature.	Default: 3 "Both-PWM 1st" Options: 0 "Disabled" 1 "Reduce CLim" 2 "Reduce PWM" 3 "Both-PWM 1st"	219
		151	[PWM Frequency] Sets the carrier frequency for the PWM output. Drive derating may occur at higher carrier frequencies. For derating information, refer to the <i>PowerFlex Reference Manual</i> . Important: If parameter 053 [Motor Cntl Sel] is set to "FVC Vector," the drive will run at 2 kHz when operating below 6 Hz.	Default: 4 kHz 2 kHz (Frames 4-6, 600/690VAC) Min/Max: 2/10 kHz Units: 2/4/8/10 kHz	



File	Group	No.	Parameter Name & Description <i>See page 1-2 for symbol descriptions</i>	Values	Related
DYNAMIC CONTROL	Load Limits	152	Vector [Droop RPM @ FLA] Selects amount of droop that the speed reference is reduced when at full load torque. Zero disables the droop function. Important: Selecting "Slip Comp" with parameter 080 in conjunction with parameter 152, may produce undesirable results.	Default: 0.0 RPM Min/Max: 0.0/200.0 RPM Units: 0.1 RPM	
		153	Vector [Regen Power Limit] FV Sets the maximum power limit allowed to transfer from the motor to the DC bus. When using an external dynamic brake, set this parameter to its maximum value.	Default: -50.0% Min/Max: -800.0/0.0% Units: 0.1%	053
		154	Vector [Current Rate Limit] FV Sets the largest allowable rate of change for the current reference signal. This number is scaled in percent of maximum motor current every 250 microseconds.	Default: 400.0% Min/Max: 1.0/800.0% Units: 0.1%	053
	145	Vector v3 [DB While Stopped]  Enables/disables dynamic brake operation when drive is stopped. DB may operate if input voltage becomes too high. Disabled = DB will only operate when drive is running. Enable = DB may operate whenever drive is energized.	Default: 0 "Disabled" Options: 0 "Disabled" 1 "Enabled"	161 162	
	155	Standard [Stop Mode A]	Default: 1 "Ramp"	157	
	156	Standard [Stop Mode B] Active stop mode. [Stop Mode A] is active unless [Stop Mode B] is selected by inputs. (¹) When using options 1 or 2, refer to the Attention statements at [DC Brake Level].	Default: 0 "Coast" Options: 0 "Coast" 1 "Ramp" ⁽¹⁾ 2 "Ramp to Hold" ⁽¹⁾ 3 "DC Brake"	158 159	
		Vector [Stop/Brk Mode A] Vector [Stop/Brk Mode B] See description above.			
	157	[DC Brake Lvl Sel] Selects the source for [DC Brake Level].	Default: 0 "DC Brake Lvl" Options: 0 "DC Brake Lvl" 1 "Analog In 1" 2 "Analog In 2"	155 156 158 159	

File	Group	No.	Parameter Name & Description <i>See page 1-2 for symbol descriptions</i>	Values	Related
DYNAMIC CONTROL	Stop/Brake Modes	158	<p>[DC Brake Level]</p> <p>Defines the DC brake current level injected into the motor when “DC Brake” is selected as a stop mode.</p> <p>The DC braking voltage used in this function is created by a PWM algorithm and may not generate the smooth holding force needed for some applications. Refer to the <i>PowerFlex Reference Manual</i>.</p> <hr/> <div style="display: flex; align-items: center;">  <p>ATTENTION: If a hazard of injury due to movement of equipment or material exists, an auxiliary mechanical braking device must be used.</p> </div> <div style="display: flex; align-items: center; margin-top: 10px;">  <p>ATTENTION: This feature should not be used with synchronous or permanent magnet motors. Motors may be demagnetized during braking.</p> </div>	<p>Default: [Rated Amps]</p> <p>Min/Max: 0/[Rated Amps] × 1.5 (Equation yields approximate maximum value.)</p> <p>Units: 0.1 Amps</p>	
		159	<p>[DC Brake Time]</p> <p>Sets the amount of time DC brake current is “injected” into the motor.</p>	<p>Default: 0.0 Secs</p> <p>Min/Max: 0.0/90.0 Secs</p> <p>Units: 0.1 Secs</p>	<p>155 thru 158</p> <p></p>
		160	<p>[Bus Reg Ki]</p> <p>Sets the responsiveness of the bus regulator.</p>	<p>Default: 450</p> <p>Min/Max: 0/5000</p> <p>Units: 1</p>	<p>161 162</p>
		161 162	<p>[Bus Reg Mode A] [Bus Reg Mode B]</p> <p> Sets the method and sequence of the DC bus regulator voltage. Choices are dynamic brake, frequency adjust or both. Sequence is determined by programming or digital input to the terminal block.</p> <p><u>Dynamic Brake Setup</u></p> <p>If a dynamic brake resistor is connected to the drive, both of these parameters must be set to either option 2, 3 or 4.</p> <p>Refer to the Attention statement on page P-4 for important information on bus regulation.</p> <hr/> <div style="display: flex; align-items: center;">  <p>ATTENTION: The drive does not offer protection for externally mounted brake resistors. A risk of fire exists if external braking resistors are not protected. External resistor packages must be self-protected from over temperature or the protective circuit shown in Figure C.1 on page C-1 (or equivalent) must be supplied.</p> </div>	<p>Default: 1 “Adjust Freq” 4 “Both-Frq 1st”</p> <p>Options: 0 “Disabled” 1 “Adjust Freq” 2 “Dynamic Brak” 3 “Both-DB 1st” 4 “Both-Frq 1st”</p>	<p>160 163</p> <p></p>

File	Group	No.	Parameter Name & Description <i>See page 1-2 for symbol descriptions</i>	Values	Related	
DYNAMIC CONTROL	Stop/Brake Modes	163	<p>[DB Resistor Type]</p> <p>Selects whether the internal or an external DB resistor will be used.</p> <p>Important: In 0-3 Frame drives, only one DB resistor can be connected to the drive. Connecting both an internal & external resistor could cause damage.</p> <p>If a dynamic brake resistor is connected to the drive, [Bus Reg Mode A & B] must be set to either option 2, 3 or 4.</p>	<p>Default: 0 "Internal Res" 2 "None" Vector</p> <p>Options: 0 "Internal Res" 1 "External Res" 2 "None"</p>	<p>161 162</p>	
		<p> ATTENTION: Equipment damage may result if a drive mounted (internal) resistor is installed and this parameter is set to "External Res" or "None." Thermal protection for the internal resistor will be disabled, resulting in possible device damage. Also see ATTENTION above.</p>				
		164	<p>[Bus Reg Kp]</p> <p>Proportional gain for the bus regulator. Used to adjust regulator response.</p>	<p>Default: 1500 Min/Max: 0/10000 Units: 1</p>		
	165	<p>[Bus Reg Kd]</p> <p>Derivative gain for the bus regulator. Used to control regulator overshoot.</p>	<p>Default: 1000 Min/Max: 0/10000 Units: 1</p>			
	166	<p>Vector [Flux Braking]</p> <p>Set to use an increase in the motor flux current to increase the motor losses, and allow a faster deceleration time when a chopper brake or regenerative capability is not available. Can be used as a stopping or fast deceleration method.</p>	<p>Default: 0 "Disabled" Options: 0 "Disabled" 1 "Enabled"</p>			
	Restart Modes	167	<p>Vector [Powerup Delay]</p> <p>Defines the programmed delay time, in seconds, before a start command is accepted after a power up.</p>	<p>Default: 0.0 Secs Min/Max: 0.0/30.0 Secs Units: 0.1 Secs</p>		
168		<p>[Start At PowerUp]</p> <p>Enables/disables a feature to issue a Start or Run command and automatically resume running at commanded speed after drive input power is restored. Requires a digital input configured for Run or Start and a valid start contact.</p>	<p>Default: 0 "Disabled" Options: 0 "Disabled" 1 "Enabled"</p>	<p></p>		
<p> ATTENTION: Equipment damage and/or personal injury may result if this parameter is used in an inappropriate application. Do not use this function without considering applicable local, national and international codes, standards, regulations or industry guidelines.</p>						

File	Group	No.	Parameter Name & Description <i>See page 1-2 for symbol descriptions</i>	Values	Related
DYNAMIC CONTROL	Restart Modes	169	[Flying Start En] Enables/disables the function which reconnects to a spinning motor at actual RPM when a start command is issued. Not required in FVC Vector mode when using an encoder.	Default: 0 "Disabled" Options: 0 "Disabled" 1 "Enabled"	170
		170	[Flying StartGain] Sets the response of the flying start function. Important: Lower gain may be required for permanent magnet motors.	Default: 4000 Min/Max: 20/32767 Units: 1	169
		174	[Auto Rstrt Tries] Sets the maximum number of times the drive attempts to reset a fault and restart.  ATTENTION: Equipment damage and/or personal injury may result if this parameter is used in an inappropriate application. Do Not use this function without considering applicable local, national and international codes, standards, regulations or industry guidelines.	Default: 0 Min/Max: 0/9 Units: 1	175
		175	[Auto Rstrt Delay] Sets the time between restart attempts when [Auto Rstrt Tries] is set to a value other than zero.	Default: 1.0 Secs Min/Max: 0.5/30.0 Secs Units: 0.1 Secs	174

File	Group	No.	Parameter Name & Description <i>See page 1-2 for symbol descriptions</i>	Values	Related																									
DYNAMIC CONTROL	Restart Modes	178	<p>[Sleep-Wake Mode]</p> <p> Enables/disables the Sleep/Wake function. Important: When enabled, the following conditions must be met:</p> <ul style="list-style-type: none"> A proper value must be programmed for [Sleep Level] & [Wake Level]. A speed reference must be selected in [Speed Ref A Sel]. At least one of the following must be programmed (and input closed) in [Digital Inx Sel]; “Enable,” “Stop=CF,” “Run,” “Run Forward,” “Run Reverse.” 	<p>Default: 0 “Disabled”</p> <p>Options: 0 “Disabled” 1 “Direct” (Enabled) 2 “Invert” (Enabled)⁽⁷⁾</p>																										
		<p> ATTENTION: Enabling the Sleep-Wake function can cause unexpected machine operation during the Wake mode. Equipment damage and/or personal injury can result if this parameter is used in an inappropriate application. Do Not use this function without considering the information below and in Appendix C. In addition, all applicable local, national & international codes, standards, regulations or industry guidelines must be considered</p>																												
Conditions Required to Start Drive ⁽¹⁾⁽²⁾⁽³⁾																														
			<table border="1" style="width: 100%; border-collapse: collapse;"> <thead> <tr> <th style="width: 15%;"></th> <th style="width: 20%;">After Power-Up</th> <th colspan="2" style="width: 40%;">After a Drive Fault</th> <th style="width: 25%;">After a Stop Command</th> </tr> <tr> <td style="text-align: center;">Input</td> <td></td> <td style="text-align: center;"><i>Reset by Stop-CF, HIM or TB</i></td> <td style="text-align: center;"><i>Reset by Clear Faults (TB)</i></td> <td style="text-align: center;"><i>HIM or TB</i></td> </tr> </thead> <tbody> <tr> <td style="text-align: center;">Stop</td> <td>Stop Closed Wake Signal</td> <td>Stop Closed Wake Signal New Start or Run Cmd.⁽⁴⁾</td> <td>Stop Closed Wake Signal</td> <td>Stop Closed <u>Direct Mode</u> Analog Sig. > Sleep Level⁽⁶⁾ <u>Invert Mode</u> Analog Sig. < Sleep Level⁽⁶⁾ New Start or Run Cmd.⁽⁴⁾</td> </tr> <tr> <td style="text-align: center;">Enable</td> <td>Enable Closed Wake Signal⁽⁴⁾</td> <td>Enable Closed Wake Signal New Start or Run Cmd.⁽⁴⁾</td> <td>Enable Closed Wake Signal</td> <td>Enable Closed <u>Direct Mode</u> Analog Sig. > Sleep Level⁽⁶⁾ <u>Invert Mode</u> Analog Sig. < Sleep Level⁽⁶⁾ New Start or Run Cmd.⁽⁴⁾</td> </tr> <tr> <td style="text-align: center;">Run Run For. Run Rev.</td> <td>Run Closed Wake Signal</td> <td>New Run Cmd.⁽⁵⁾ Wake Signal</td> <td>Run Closed Wake Signal</td> <td>New Run Cmd.⁽⁵⁾ Wake Signal</td> </tr> </tbody> </table>		After Power-Up	After a Drive Fault		After a Stop Command	Input		<i>Reset by Stop-CF, HIM or TB</i>	<i>Reset by Clear Faults (TB)</i>	<i>HIM or TB</i>	Stop	Stop Closed Wake Signal	Stop Closed Wake Signal New Start or Run Cmd. ⁽⁴⁾	Stop Closed Wake Signal	Stop Closed <u>Direct Mode</u> Analog Sig. > Sleep Level ⁽⁶⁾ <u>Invert Mode</u> Analog Sig. < Sleep Level ⁽⁶⁾ New Start or Run Cmd. ⁽⁴⁾	Enable	Enable Closed Wake Signal ⁽⁴⁾	Enable Closed Wake Signal New Start or Run Cmd. ⁽⁴⁾	Enable Closed Wake Signal	Enable Closed <u>Direct Mode</u> Analog Sig. > Sleep Level ⁽⁶⁾ <u>Invert Mode</u> Analog Sig. < Sleep Level ⁽⁶⁾ New Start or Run Cmd. ⁽⁴⁾	Run Run For. Run Rev.	Run Closed Wake Signal	New Run Cmd. ⁽⁵⁾ Wake Signal	Run Closed Wake Signal	New Run Cmd. ⁽⁵⁾ Wake Signal		
	After Power-Up	After a Drive Fault		After a Stop Command																										
Input		<i>Reset by Stop-CF, HIM or TB</i>	<i>Reset by Clear Faults (TB)</i>	<i>HIM or TB</i>																										
Stop	Stop Closed Wake Signal	Stop Closed Wake Signal New Start or Run Cmd. ⁽⁴⁾	Stop Closed Wake Signal	Stop Closed <u>Direct Mode</u> Analog Sig. > Sleep Level ⁽⁶⁾ <u>Invert Mode</u> Analog Sig. < Sleep Level ⁽⁶⁾ New Start or Run Cmd. ⁽⁴⁾																										
Enable	Enable Closed Wake Signal ⁽⁴⁾	Enable Closed Wake Signal New Start or Run Cmd. ⁽⁴⁾	Enable Closed Wake Signal	Enable Closed <u>Direct Mode</u> Analog Sig. > Sleep Level ⁽⁶⁾ <u>Invert Mode</u> Analog Sig. < Sleep Level ⁽⁶⁾ New Start or Run Cmd. ⁽⁴⁾																										
Run Run For. Run Rev.	Run Closed Wake Signal	New Run Cmd. ⁽⁵⁾ Wake Signal	Run Closed Wake Signal	New Run Cmd. ⁽⁵⁾ Wake Signal																										
<p>(1) When power is cycled, if all of the above conditions are present after power is restored, restart will occur.</p> <p>(2) If all of the above conditions are present when [Sleep-Wake Mode] is “enabled,” the drive will start.</p> <p>(3) Refer to Reference Control in the Installation Instructions for information on determining the active speed reference. The Sleep/Wake function and the speed reference may be assigned to the same input.</p> <p>(4) Command must be issued from HIM, TB or network.</p> <p>(5) Run Command must be cycled.</p> <p>(6) Signal does not need to be greater than wake level.</p> <p>(7) Vector firmware 3.xxx & later. For Invert function, refer to [Analog In x Loss].</p>																														

File	Group	No.	Parameter Name & Description <i>See page 1-2 for symbol descriptions</i>	Values	Related
DYNAMIC CONTROL	Restart Modes	179	[Sleep-Wake Ref]  Selects the source of the input controlling the Sleep-Wake function.	Default: 2 "Analog In 2" Options: 1 "Analog In 1" 2 "Analog In 2"	
		180	[Wake Level] Defines the analog input level that will start the drive.	Default: 6.000 mA, 6.000 Volts Min/Max: [Sleep Level]/20.000 mA 10.000 Volts Units: 0.001 mA 0.001 Volts	181
		181	[Wake Time] Defines the amount of time at or above [Wake Level] before a Start is issued.	Default: 1.0 Secs 0.0 Secs Vector Min/Max: 0.0/30.0 Secs Units: 0.0/1000.0 Secs Vector 0.1 Secs	180
		182	[Sleep Level] Defines the analog input level that will stop the drive.	Default: 5.000 mA, 5.000 Volts Min/Max: 4.000 mA/[Wake Level] 0.000 Volts/[Wake Level] Units: 0.001 mA 0.001 Volts	183
		183	[Sleep Time] Defines the amount of time at or below [Sleep Level] before a Stop is issued.	Default: 1.0 Secs 0.0 Secs Vector Min/Max: 0.0/30.0 Secs Units: 0.0/1000.0 Secs Vector 0.1 Secs	182
	Power Loss	177	 Vector v3 [Gnd Warn Level] Sets the level at which a ground warning fault will occur. Configure with [Alarm Config 1].	Default: 3.0 Amps Min/Max: 1.0/5.0 Amps Units: 0.1 Amps	259
		184	[Power Loss Mode] Sets the reaction to a loss of input power. Power loss is recognized when: <ul style="list-style-type: none"> DC bus voltage is $\leq 73\%$ of [DC Bus Memory] and [Power Loss Mode] is set to "Coast". DC bus voltage is $\leq 82\%$ of [DC Bus Memory] and [Power Loss Mode] is set to "Decel". 	Default: 0 "Coast" Options: 0 "Coast" 1 "Decel" 2 "Continue" 3 "Coast Input" 4 "Decel Input"	013 185
		185	[Power Loss Time] Sets the time that the drive will remain in power loss mode before a fault is issued.	Default: 0.5 Secs Min/Max: 0.0/60.0 Secs Units: 0.1 Secs	184

File	Group	No.	Parameter Name & Description <i>See page 1-2 for symbol descriptions</i>	Values	Related
DYNAMIC CONTROL	Power Loss	186	[Power Loss Level] Sets the level at which the [Power Loss Mode] selection will occur. The drive can use the percentages referenced in [Power Loss Mode] or a trigger point can be set for line loss detection as follows: $V_{\text{trigger}} = [\text{DC Bus Memory}] - [\text{Power Loss Level}]$ A digital input (programmed to "29, Pwr Loss Lvl") is used to toggle between fixed percentages and the detection level.	Default: Drive Rated Volts Min/Max: 0.0/999.9 VDC Units: 0.1 VDC	
		187	Vector v3 [Load Loss Level] Sets the percentage of motor nameplate torque at which a load loss alarm will occur.	Default: 200.0% Min/Max: 0.0/800.0% Units: 0.1%	211 259
		188	Vector v3 [Load Loss Time] Sets the time that current is below the level set in [Load Loss Level] before a fault occurs.	Default: 0.0 Secs Min/Max: 0.0/30.0 Secs Units: 0.1 Secs	187
		189	Vector v3 [Shear Pin Time] Sets the time that the drive is at or above current limit before a fault occurs. Zero disables this feature.	Default: 0.0 Secs Min/Max: 0.0/30.0 Secs Units: 0.1 Secs	238

Utility File

File	Group	No.	Parameter Name & Description <i>See page 1-2 for symbol descriptions</i>	Values	Related					
UTILITY	Direction Config	190	[Direction Mode] Selects method for changing direction.	Default: 0 "Unipolar"	320					
		<table border="1"> <tr> <td>Mode</td> <td>Direction Change</td> </tr> <tr> <td>Unipolar</td> <td>Drive Logic</td> </tr> <tr> <td>Bipolar</td> <td>Sign of Reference</td> </tr> <tr> <td>Reverse Dis</td> <td>Not Changeable</td> </tr> </table>	Mode	Direction Change	Unipolar	Drive Logic	Bipolar	Sign of Reference	Reverse Dis	Not Changeable
Mode	Direction Change									
Unipolar	Drive Logic									
Bipolar	Sign of Reference									
Reverse Dis	Not Changeable									

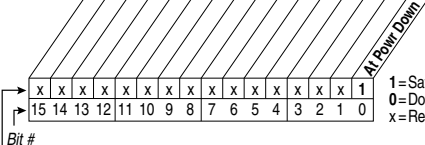
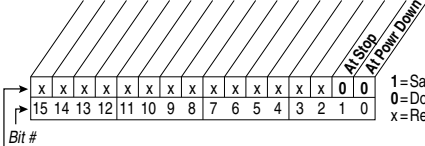
File	Group	No. Parameter Name & Description <i>See page 1-2 for symbol descriptions</i>	Values	Related
UTILITY	HIM Ref Config	192 [Save HIM Ref] Enables a feature to save the present frequency reference value issued by the HIM to Drive memory on power loss. Value is restored to the HIM on power up.  <p>Bit #</p> <p>Factory Default Bit Values</p>	1 = Save at Power Down 0 = Do Not Save x = Reserved	
		193 [Man Ref Preload] Enables/disables a feature to automatically load the present "Auto" frequency reference value into the HIM when "Manual" is selected. Allows smooth speed transition from "Auto" to "Manual." Default: 0 "Disabled" Options: 0 "Disabled" 1 "Enabled"		
	MOP Config	194 [Save MOP Ref] Enables/disables the feature that saves the present MOP frequency reference at power down or at stop.  <p>Bit #</p> <p>Factory Default Bit Values</p>	1 = Save at Power Down 0 = Do Not Save x = Reserved	
		195 [MOP Rate] Sets rate of change of the MOP reference in response to a digital input. Default: 1.0 Hz/s 30.0 RPM/s Vector Min/Max: 0.2/[Maximum Freq] 6.0/[Maximum Freq] Vector Units: 0.1 Hz/s 0.1 RPM/s Vector		
Drive Memory		196 [Param Access Lvl] Selects the parameter display level. Basic = Reduced param. set Advanced = Full param. set Fan/Pump = Reduced fan/pump set Adv Fan/Pump = Full fan/pump set (1) Standard Control drives v3.001 & up.	Default: 0 "Basic" Options: 0 "Basic" 1 "Advanced" 2 "Reserved" 3 "Fan/Pump" ⁽¹⁾ 4 "Adv Fan/Pump" ⁽¹⁾	

File	Group	No.	Parameter Name & Description <i>See page 1-2 for symbol descriptions</i>	Values	Related
UTILITY	Drive Memory	197	<p>[Reset To Defaults]</p> <p>Resets parameters to factory defaults except [Language], [Param Access Lvl], [Voltage Class] & [TorqProve Cnfg] (params 196, 201, 202 & 600).</p> <ul style="list-style-type: none"> Option 1 resets parameters to factory defaults based on [Voltage Class]. Options 2 & 3 will reset parameters to factory defaults and set [Voltage Class] to low or high voltage settings. <p>Important: Frames 5 & 6 - the internal fan voltage may have to be changed when using Option 2 or 3. See "Selecting /Verifying Fan Voltage" in the Installation Instructions.</p>	<p>Default: 0 "Ready"</p> <p>Options: 0 "Ready" 1 "Factory" 2 "Low Voltage" 3 "High Voltage"</p>	041 thru 047 054 055 062 063 069 thru 072 082 148 158
		198	<p>[Load Frm Usr Set]</p> <p>Loads a previously saved set of parameter values from a selected user set location in drive nonvolatile memory to active drive memory.</p>	<p>Default: 0 "Ready"</p> <p>Options: 0 "Ready" 1 "User Set 1" 2 "User Set 2" 3 "User Set 3"</p>	199
		199	<p>[Save To User Set]</p> <p>Saves the parameter values in active drive memory to a user set in drive nonvolatile memory.</p>	<p>Default: 0 "Ready"</p> <p>Options: 0 "Ready" 1 "User Set 1" 2 "User Set 2" 3 "User Set 3"</p>	198
		200	<p>[Reset Meters]</p> <p>Resets selected meters to zero.</p>	<p>Default: 0 "Ready"</p> <p>Options: 0 "Ready" 1 "MWh" 2 "Elapsed Time"</p>	
		201	<p>[Language]</p> <p>Selects the display language when using an LCD HIM. This parameter is not functional with an LED HIM.</p> <p>Options 6, 8 and 9 are "Reserved."</p>	<p>Default: 0 "Not Selected"</p> <p>Options: 0 "Not Selected" 1 "English" 2 "Francais" 3 "Español" 4 "Italiano" 5 "Deutsch" 7 "Português" 10 "Nederlands"</p>	

File	Group	No.	Parameter Name & Description <i>See page 1-2 for symbol descriptions</i>	Values	Related																																																																																																																																																																																																													
UTILITY	Drive Memory	202	<p>[Voltage Class]</p> <p>Configures the drive current rating and associates it with the selected voltage (i.e. 400 or 480V). Normally used when downloading parameter sets. Options 2 & 3 indicate status only. Selecting Option 4 or 5 will covert/configure the drive. Min/Max & Default values will be changed for parameters; 41-47, 54, 55, 62, 63, 69, 70-72, 82, 148, 158.</p> <p>Important: Frames 5 & 6 - the internal fan voltage may have to be changed when using Option 4 or 5. Refer to the Installation Instructions.</p>	<p>Default: Based on Drive Cat. No.</p> <p>Options: 2 "Low Voltage" 3 "High Voltage" 4 "Reserved"⁽¹⁾ 5 "Convert Lo V" Vector "Reserved"⁽¹⁾ "Convert Hi V" Vector</p> <p>(1) Vector firmware v3.001 & up.</p>	041 thru 047 054 055 062 063 069 thru 072 082 148 158																																																																																																																																																																																																													
		203	<p>[Drive Checksum]</p> <p>Provides a checksum value that indicates whether or not a change in drive programming has occurred.</p>	<p>Default: Read Only</p> <p>Min/Max: 0/65535</p> <p>Units: 1</p>																																																																																																																																																																																																														
	Diagnostics	209	<p>[Drive Status 1]</p> <p>Present operating condition of the drive.</p> <table border="1" style="margin-left: auto; margin-right: auto;"> <tr> <td style="writing-mode: vertical-rl; transform: rotate(180deg);">Speed Ref ID 3^(B)</td> <td style="writing-mode: vertical-rl; transform: rotate(180deg);">Speed Ref ID 2^(B)</td> <td style="writing-mode: vertical-rl; transform: rotate(180deg);">Speed Ref ID 1^(B)</td> <td style="writing-mode: vertical-rl; transform: rotate(180deg);">Local ID 0^(B)</td> <td style="writing-mode: vertical-rl; transform: rotate(180deg);">Local ID 2^(B)</td> <td style="writing-mode: vertical-rl; transform: rotate(180deg);">Local ID 1^(B)</td> <td style="writing-mode: vertical-rl; transform: rotate(180deg);">All Speed Faulted</td> <td style="writing-mode: vertical-rl; transform: rotate(180deg);">Alarm</td> <td style="writing-mode: vertical-rl; transform: rotate(180deg);">Decelerating</td> <td style="writing-mode: vertical-rl; transform: rotate(180deg);">Accelerating</td> <td style="writing-mode: vertical-rl; transform: rotate(180deg);">Actual Dir</td> <td style="writing-mode: vertical-rl; transform: rotate(180deg);">Command Dir</td> <td style="writing-mode: vertical-rl; transform: rotate(180deg);">Active</td> <td style="writing-mode: vertical-rl; transform: rotate(180deg);">Ready</td> </tr> <tr> <td style="text-align: center;">0</td> <td style="text-align: center;">0</td> <td style="text-align: center;">0</td> <td style="text-align: center;">0</td> <td style="text-align: center;">1</td> <td style="text-align: center;">1</td> <td style="text-align: center;">1</td> <td style="text-align: center;">0</td> <td style="text-align: center;">0</td> <td style="text-align: center;">0</td> <td style="text-align: center;">1</td> <td style="text-align: center;">1</td> <td style="text-align: center;">0</td> <td style="text-align: center;">0</td> </tr> <tr> <td style="text-align: center;">15</td> <td style="text-align: center;">14</td> <td style="text-align: center;">13</td> <td style="text-align: center;">12</td> <td style="text-align: center;">11</td> <td style="text-align: center;">10</td> <td style="text-align: center;">9</td> <td style="text-align: center;">8</td> <td style="text-align: center;">7</td> <td style="text-align: center;">6</td> <td style="text-align: center;">5</td> <td style="text-align: center;">4</td> <td style="text-align: center;">3</td> <td style="text-align: center;">2</td> <td style="text-align: center;">1</td> <td style="text-align: center;">0</td> </tr> </table> <p>Bit #</p> <p>1 = Condition True 0 = Condition False x = Reserved</p> <table border="1" style="width: 100%; margin-top: 10px;"> <thead> <tr> <th colspan="4">Bits⁽²⁾</th> <th>Description</th> <th colspan="3">Bits⁽¹⁾</th> <th>Description</th> </tr> <tr> <th>15</th> <th>14</th> <th>13</th> <th>12</th> <th></th> <th>11</th> <th>10</th> <th>9</th> <th></th> </tr> </thead> <tbody> <tr><td>0</td><td>0</td><td>0</td><td>0</td><td>Ref A Auto</td><td>0</td><td>0</td><td>0</td><td>Port 0 (TB)</td></tr> <tr><td>0</td><td>0</td><td>0</td><td>1</td><td>Ref B Auto</td><td>0</td><td>0</td><td>1</td><td>Port 1</td></tr> <tr><td>0</td><td>0</td><td>1</td><td>0</td><td>Preset 2 Auto</td><td>0</td><td>1</td><td>0</td><td>Port 2</td></tr> <tr><td>0</td><td>0</td><td>1</td><td>1</td><td>Preset 3 Auto</td><td>0</td><td>1</td><td>1</td><td>Port 3</td></tr> <tr><td>0</td><td>1</td><td>0</td><td>0</td><td>Preset 4 Auto</td><td>1</td><td>0</td><td>0</td><td>Port 4</td></tr> <tr><td>0</td><td>1</td><td>0</td><td>1</td><td>Preset 5 Auto</td><td>1</td><td>0</td><td>1</td><td>Port 5</td></tr> <tr><td>0</td><td>1</td><td>1</td><td>0</td><td>Preset 6 Auto</td><td>1</td><td>1</td><td>0</td><td>Port 6</td></tr> <tr><td>0</td><td>1</td><td>1</td><td>1</td><td>Preset 7 Auto</td><td>1</td><td>1</td><td>1</td><td>No Local Control</td></tr> <tr><td>1</td><td>0</td><td>0</td><td>0</td><td>TB Manual</td><td></td><td></td><td></td><td></td></tr> <tr><td>1</td><td>0</td><td>0</td><td>1</td><td>Port 1 Manual</td><td></td><td></td><td></td><td></td></tr> <tr><td>1</td><td>0</td><td>1</td><td>0</td><td>Port 2 Manual</td><td></td><td></td><td></td><td></td></tr> <tr><td>1</td><td>0</td><td>1</td><td>1</td><td>Port 3 Manual</td><td></td><td></td><td></td><td></td></tr> <tr><td>1</td><td>1</td><td>0</td><td>0</td><td>Port 4 Manual</td><td></td><td></td><td></td><td></td></tr> <tr><td>1</td><td>1</td><td>0</td><td>1</td><td>Port 5 Manual</td><td></td><td></td><td></td><td></td></tr> <tr><td>1</td><td>1</td><td>1</td><td>0</td><td>Port 6 Manual</td><td></td><td></td><td></td><td></td></tr> <tr><td>1</td><td>1</td><td>1</td><td>1</td><td>Jog Ref</td><td></td><td></td><td></td><td></td></tr> </tbody> </table>	Speed Ref ID 3 ^(B)	Speed Ref ID 2 ^(B)	Speed Ref ID 1 ^(B)	Local ID 0 ^(B)	Local ID 2 ^(B)	Local ID 1 ^(B)	All Speed Faulted	Alarm	Decelerating	Accelerating	Actual Dir	Command Dir	Active	Ready	0	0	0	0	1	1	1	0	0	0	1	1	0	0	15	14	13	12	11	10	9	8	7	6	5	4	3	2	1	0	Bits ⁽²⁾				Description	Bits ⁽¹⁾			Description	15	14	13	12		11	10	9		0	0	0	0	Ref A Auto	0	0	0	Port 0 (TB)	0	0	0	1	Ref B Auto	0	0	1	Port 1	0	0	1	0	Preset 2 Auto	0	1	0	Port 2	0	0	1	1	Preset 3 Auto	0	1	1	Port 3	0	1	0	0	Preset 4 Auto	1	0	0	Port 4	0	1	0	1	Preset 5 Auto	1	0	1	Port 5	0	1	1	0	Preset 6 Auto	1	1	0	Port 6	0	1	1	1	Preset 7 Auto	1	1	1	No Local Control	1	0	0	0	TB Manual					1	0	0	1	Port 1 Manual					1	0	1	0	Port 2 Manual					1	0	1	1	Port 3 Manual					1	1	0	0	Port 4 Manual					1	1	0	1	Port 5 Manual					1	1	1	0	Port 6 Manual					1	1	1	1	Jog Ref					Read Only
Speed Ref ID 3 ^(B)	Speed Ref ID 2 ^(B)	Speed Ref ID 1 ^(B)	Local ID 0 ^(B)	Local ID 2 ^(B)	Local ID 1 ^(B)	All Speed Faulted	Alarm	Decelerating	Accelerating	Actual Dir	Command Dir	Active	Ready																																																																																																																																																																																																					
0	0	0	0	1	1	1	0	0	0	1	1	0	0																																																																																																																																																																																																					
15	14	13	12	11	10	9	8	7	6	5	4	3	2	1	0																																																																																																																																																																																																			
Bits ⁽²⁾				Description	Bits ⁽¹⁾			Description																																																																																																																																																																																																										
15	14	13	12		11	10	9																																																																																																																																																																																																											
0	0	0	0	Ref A Auto	0	0	0	Port 0 (TB)																																																																																																																																																																																																										
0	0	0	1	Ref B Auto	0	0	1	Port 1																																																																																																																																																																																																										
0	0	1	0	Preset 2 Auto	0	1	0	Port 2																																																																																																																																																																																																										
0	0	1	1	Preset 3 Auto	0	1	1	Port 3																																																																																																																																																																																																										
0	1	0	0	Preset 4 Auto	1	0	0	Port 4																																																																																																																																																																																																										
0	1	0	1	Preset 5 Auto	1	0	1	Port 5																																																																																																																																																																																																										
0	1	1	0	Preset 6 Auto	1	1	0	Port 6																																																																																																																																																																																																										
0	1	1	1	Preset 7 Auto	1	1	1	No Local Control																																																																																																																																																																																																										
1	0	0	0	TB Manual																																																																																																																																																																																																														
1	0	0	1	Port 1 Manual																																																																																																																																																																																																														
1	0	1	0	Port 2 Manual																																																																																																																																																																																																														
1	0	1	1	Port 3 Manual																																																																																																																																																																																																														
1	1	0	0	Port 4 Manual																																																																																																																																																																																																														
1	1	0	1	Port 5 Manual																																																																																																																																																																																																														
1	1	1	0	Port 6 Manual																																																																																																																																																																																																														
1	1	1	1	Jog Ref																																																																																																																																																																																																														

File	Group	No.	Parameter Name & Description <i>See page 1-2 for symbol descriptions</i>	Values	Related
UTILITY	Diagnostics	210	[Drive Status 2] Present operating condition of the drive. 	Read Only	209
		211	[Drive Alarm 1] Alarm conditions that currently exist in the drive. 	Read Only	211
		212	[Drive Alarm 2] Alarm conditions that currently exist in the drive. 	Read Only	211

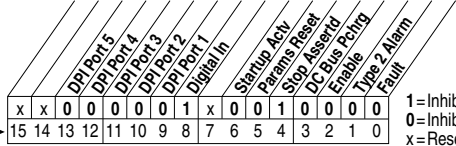
File	Group	No.	Parameter Name & Description <i>See page 1-2 for symbol descriptions</i>	Values	Related
UTILITY	Diagnostics	213	<p>[Speed Ref Source]</p> <p>Displays the source of the speed reference to the drive. (1) Vector firmware 3.001 and later.</p>	<p>Default: Read Only</p> <p>Options:</p> <ul style="list-style-type: none"> 0 "PI Output" 1 "Analog In 1" 2 "Analog In 2" 3-6 "Reserved" 7 "Pulse In" 8 "Encoder" 9 "MOP Level" 10 "Jog Speed 1" 11-17 "Preset Spd1-7" 18 "DPI Port 1" 19 "DPI Port 2" 20 "DPI Port 3" 21 "DPI Port 4" 22 "DPI Port 5" 23 "Reserved" 24 "Auto Tune" Vector 25 "Jog Speed 2" Vector 26 "Scale Block 1"⁽¹⁾ 27 "Scale Block 2"⁽¹⁾ 28 "Scale Block 3"⁽¹⁾ 29 "Scale Block 4"⁽¹⁾ 	<p>090 093 096 101</p>
		214	<p>[Start Inhibits]</p> <p>Displays the inputs currently preventing the drive from starting.</p> <div style="text-align: center;">  <p>The diagram shows a 16-bit register labeled 'Bit #' from 15 to 0. Above each bit is an input signal name. Bit 15 (x), 14 (x), 13 (x), 12 (0), 11 (0), 10 (0), 9 (0), 8 (0), 7 (1), 6 (x), 5 (0), 4 (0), 3 (1), 2 (0), 1 (0), 0 (0).</p> </div> <p>1 = Inhibit True 0 = Inhibit False x = Reserved</p>	Read Only	
		215	<p>[Last Stop Source]</p> <p>Displays the source that initiated the most recent stop sequence. It will be cleared (set to 0) during the next start sequence.</p>	<p>Default: Read Only</p> <p>Options:</p> <ul style="list-style-type: none"> 0 "Pwr Removed" 1-5 "DPI Port 1-5" 6 "Reserved" 7 "Digital In" 8 "Fault" 9 "Not Enabled" 10 "Sleep" 11 "Jog" 12 "Autotune" Vector 13 "Precharge" Vector 	<p>361 362 363 364 365 366</p>

File	Group	No.	Parameter Name & Description <i>See page 1-2 for symbol descriptions</i>	Values	Related
UTILITY	Diagnostics	216	[Dig In Status] Status of the digital inputs. 	Read Only	361 thru 366
		217	[Dig Out Status] Status of the digital outputs. 	Read Only	380 thru 384
		218	[Drive Temp] Present operating temperature of the drive power section.	Default: Read Only Min/Max: 0.0/100.0% Units: 0.1%	
		219	[Drive OL Count] Accumulated percentage of drive overload. Continuously operating the drive over 100% of its rating will increase this value to 100% and cause a drive fault or foldback depending on the setting of [Drive OL Mode].	Default: Read Only Min/Max: 0.0/100.0% Units: 0.1%	150
		220	[Motor OL Count] Accumulated percentage of motor overload. Continuously operating the motor over 100% of the motor overload setting will increase this value to 100% and cause a drive fault.	Default: Read Only Min/Max: 0.0/100.0% Units: 0.1%	047 048
		224	Standard [Fault Frequency] Captures and displays the output speed of the drive at the time of the last fault.	Default: Read Only Min/Max: 0.0+[Maximum Freq] Units: 0.1 Hz	225 thru 230
			Vector [Fault Speed] See description above.	Default: Read Only Min/Max: 0.0+[Maximum Freq] 0.0+[Maximum Speed] Units: 0.1 Hz 0.1 RPM	079 225 thru 230
		225	[Fault Amps] Captures and displays motor amps at the time of the last fault.	Default: Read Only Min/Max: 0.0/[Rated Amps] × 2 Units: 0.1 Amps	224 thru 230

File	Group	No.	Parameter Name & Description <i>See page 1-2 for symbol descriptions</i>	Values	Related																																																	
UTILITY	Diagnostics	226	[Fault Bus Volts] Captures and displays the DC bus voltage of the drive at the time of the last fault.	Default: Read Only Min/Max: 0.0/Max Bus Volts Units: 0.1 VDC	224 thru 230																																																	
		227	[Status 1 @ Fault] Captures and displays [Drive Status 1] bit pattern at the time of the last fault.	Read Only	209 224 thru 230																																																	
		<table border="1" style="margin-left: auto; margin-right: auto;"> <tr> <td style="transform: rotate(-45deg);">Spt Ref ID 3</td><td style="transform: rotate(-45deg);">Spt Ref ID 2</td><td style="transform: rotate(-45deg);">Spt Ref ID 1</td><td style="transform: rotate(-45deg);">Local ID 0</td><td style="transform: rotate(-45deg);">Local ID 2</td><td style="transform: rotate(-45deg);">Local ID 1</td><td style="transform: rotate(-45deg);">Local ID 0</td><td style="transform: rotate(-45deg);">AI Speed</td><td style="transform: rotate(-45deg);">Faulted</td><td style="transform: rotate(-45deg);">Alarm</td><td style="transform: rotate(-45deg);">Decelerating</td><td style="transform: rotate(-45deg);">Accelerating</td><td style="transform: rotate(-45deg);">Active Dtk</td><td style="transform: rotate(-45deg);">Command Dtk</td><td style="transform: rotate(-45deg);">Active</td><td style="transform: rotate(-45deg);">Ready</td> </tr> <tr> <td>0</td><td>0</td><td>0</td><td>0</td><td>1</td><td>1</td><td>1</td><td>0</td><td>1</td><td>0</td><td>0</td><td>0</td><td>1</td><td>1</td><td>0</td><td>0</td> </tr> <tr> <td>15</td><td>14</td><td>13</td><td>12</td><td>11</td><td>10</td><td>9</td><td>8</td><td>7</td><td>6</td><td>5</td><td>4</td><td>3</td><td>2</td><td>1</td><td>0</td> </tr> </table> <p>Bit #</p> <p>1 = Condition True 0 = Condition False x = Reserved</p>			Spt Ref ID 3	Spt Ref ID 2	Spt Ref ID 1	Local ID 0	Local ID 2	Local ID 1	Local ID 0	AI Speed	Faulted	Alarm	Decelerating	Accelerating	Active Dtk	Command Dtk	Active	Ready	0	0	0	0	1	1	1	0	1	0	0	0	1	1	0	0	15	14	13	12	11	10	9	8	7	6	5	4	3	2	1	0		
		Spt Ref ID 3	Spt Ref ID 2	Spt Ref ID 1	Local ID 0	Local ID 2	Local ID 1	Local ID 0	AI Speed	Faulted	Alarm	Decelerating	Accelerating	Active Dtk	Command Dtk	Active	Ready																																					
0	0	0	0	1	1	1	0	1	0	0	0	1	1	0	0																																							
15	14	13	12	11	10	9	8	7	6	5	4	3	2	1	0																																							
228	[Status 2 @ Fault] Captures and displays [Drive Status 2] bit pattern at the time of the last fault.	Read Only	210 224 thru 230																																																			
<table border="1" style="margin-left: auto; margin-right: auto;"> <tr> <td style="transform: rotate(-45deg);">Dp at 500 x</td><td style="transform: rotate(-45deg);">Motor Overld</td><td style="transform: rotate(-45deg);">Bus Free Reg</td><td style="transform: rotate(-45deg);">Autorst Act</td><td style="transform: rotate(-45deg);">Autorst Clgh</td><td style="transform: rotate(-45deg);">DB Active *</td><td style="transform: rotate(-45deg);">Auto Tuning</td><td style="transform: rotate(-45deg);">DC Braking</td><td style="transform: rotate(-45deg);">Stopping</td><td style="transform: rotate(-45deg);">Jogging</td><td style="transform: rotate(-45deg);">Running</td><td style="transform: rotate(-45deg);">Active</td><td style="transform: rotate(-45deg);">Ready</td> </tr> <tr> <td>x</td><td>0</td><td>0</td><td>0</td><td>0</td><td>0</td><td>0</td><td>0</td><td>0</td><td>0</td><td>0</td><td>0</td><td>0</td> </tr> <tr> <td>15</td><td>14</td><td>13</td><td>12</td><td>11</td><td>10</td><td>9</td><td>8</td><td>7</td><td>6</td><td>5</td><td>4</td><td>3</td><td>2</td><td>1</td><td>0</td> </tr> </table> <p>Bit #</p> <p>* Vector firmware 3.001 & later</p> <p>1 = Condition True 0 = Condition False x = Reserved</p>			Dp at 500 x	Motor Overld	Bus Free Reg	Autorst Act	Autorst Clgh	DB Active *	Auto Tuning	DC Braking	Stopping	Jogging	Running	Active	Ready	x	0	0	0	0	0	0	0	0	0	0	0	0	15	14	13	12	11	10	9	8	7	6	5	4	3	2	1	0										
Dp at 500 x	Motor Overld	Bus Free Reg	Autorst Act	Autorst Clgh	DB Active *	Auto Tuning	DC Braking	Stopping	Jogging	Running	Active	Ready																																										
x	0	0	0	0	0	0	0	0	0	0	0	0																																										
15	14	13	12	11	10	9	8	7	6	5	4	3	2	1	0																																							
229	[Alarm 1 @ Fault] Captures and displays [Drive Alarm 1] at the time of the last fault.	Read Only	211 224 thru 230																																																			
<table border="1" style="margin-left: auto; margin-right: auto;"> <tr> <td style="transform: rotate(-45deg);">Ground Warn *</td><td style="transform: rotate(-45deg);">Load Loss *</td><td style="transform: rotate(-45deg);">In Phase Loss *</td><td style="transform: rotate(-45deg);">Micro Loss *</td><td style="transform: rotate(-45deg);">Waking</td><td style="transform: rotate(-45deg);">Decel Inhibit</td><td style="transform: rotate(-45deg);">Dry OL Lvl 2</td><td style="transform: rotate(-45deg);">Dry OL Lvl 1</td><td style="transform: rotate(-45deg);">IndPhases OH</td><td style="transform: rotate(-45deg);">Avg In Loss</td><td style="transform: rotate(-45deg);">Sur At PwrUp</td><td style="transform: rotate(-45deg);">Power Loss</td><td style="transform: rotate(-45deg);">UnderVoltage</td><td style="transform: rotate(-45deg);">Prechg Actv</td> </tr> <tr> <td>x</td><td>0</td><td>0</td><td>0</td><td>0</td><td>0</td><td>0</td><td>0</td><td>x</td><td>0</td><td>0</td><td>0</td><td>0</td><td>0</td> </tr> <tr> <td>15</td><td>14</td><td>13</td><td>12</td><td>11</td><td>10</td><td>9</td><td>8</td><td>7</td><td>6</td><td>5</td><td>4</td><td>3</td><td>2</td><td>1</td><td>0</td> </tr> </table> <p>Bit #</p> <p>* Vector firmware 3.001 & later</p> <p>1 = Condition True 0 = Condition False x = Reserved</p>			Ground Warn *	Load Loss *	In Phase Loss *	Micro Loss *	Waking	Decel Inhibit	Dry OL Lvl 2	Dry OL Lvl 1	IndPhases OH	Avg In Loss	Sur At PwrUp	Power Loss	UnderVoltage	Prechg Actv	x	0	0	0	0	0	0	0	x	0	0	0	0	0	15	14	13	12	11	10	9	8	7	6	5	4	3	2	1	0								
Ground Warn *	Load Loss *	In Phase Loss *	Micro Loss *	Waking	Decel Inhibit	Dry OL Lvl 2	Dry OL Lvl 1	IndPhases OH	Avg In Loss	Sur At PwrUp	Power Loss	UnderVoltage	Prechg Actv																																									
x	0	0	0	0	0	0	0	x	0	0	0	0	0																																									
15	14	13	12	11	10	9	8	7	6	5	4	3	2	1	0																																							

File	Group	No.	Parameter Name & Description <i>See page 1-2 for symbol descriptions</i>	Values	Related
UTILITY	Diagnostics	230	[Alarm 2 @ Fault] Captures and displays [Drive Alarm 2] at the time of the last fault. 	Read Only	212 224 thru 230
		234	[Testpoint 1 Sel] Selects the function whose value is displayed value in [Testpoint x Data]. These are internal values that are not accessible through parameters. See Testpoint Codes and Functions on page 2-16 for a listing of available codes and functions.	Default: 499	
		236	[Testpoint 2 Sel] Same as [Testpoint 1 Sel].	Min/Max: 0/65535 Units: 1	
		235	[Testpoint 1 Data] The present value of the function selected in [Testpoint x Sel].	Default: Read Only	
		237	[Testpoint 2 Data] The present value of the function selected in [Testpoint x Sel].	Min/Max: 0/4294967295 Units: 1	
FAULTS	Faults	238	[Fault Config 1] Enables/disables annunciation of the listed faults. 	Default: Read Only Min/Max: 0/4294967295 Units: 1	
		240	[Fault Clear] Resets a fault and clears the fault queue.	Default: 0 "Ready" Options: 0 "Ready" 1 "Clear Faults" 2 "Clr Fit Que"	
			Factory Default Bit Values * Vector firmware 3.001 & later		





File	Group	No.	Parameter Name & Description <i>See page 1-2 for symbol descriptions</i>	Values	Related
UTILITY	Faults	241	[Fault Clear Mode] Enables/disables a fault reset (clear faults) attempt from any source. This does not apply to fault codes which are cleared indirectly via other actions.	Default: 1 "Enabled" Options: 0 "Disabled" 1 "Enabled"	
		242	[Power Up Marker] ³² Elapsed hours since initial drive power up. This value will rollover to 0 after the drive has been powered on for more than the max value shown. For relevance to most recent power up see [Fault x Time].	Default: Read Only Min/Max: 0.0000/429496.7295 Hr 0.0/429496.7 Hr Vector 0.0000/214748.3647 Hr v3 Units: 0.0001 Hr 0.1 Hr Vector	244 246 248 250 252 254 256 258
		243	[Fault 1 Code]	Default: Read Only	
		245	[Fault 2 Code]		
		247	[Fault 3 Code]	Min/Max: 0/65535	
		249	[Fault 4 Code]	Units: 0	
		251	[Fault 5 Code]		
		253	[Fault 6 Code]		
		255	[Fault 7 Code]		
		257	[Fault 8 Code] A code that represents the fault that tripped the drive. The codes will appear in these parameters in the order they occur ([Fault 1 Code] = the most recent fault).		
244	[Fault 1 Time]	Default: Read Only		242	
246	[Fault 2 Time]				
248	[Fault 3 Time]	Min/Max: 0.0000/429496.7295 Hr 0.0000/214748.3647 Hr v3			
250	[Fault 4 Time]	Units: 0.0001 Hr			
252	[Fault 5 Time]				
254	[Fault 6 Time]				
256	[Fault 7 Time]				
258	[Fault 8 Time] ³² The time between initial drive power up and the occurrence of the associated trip fault. Can be compared to [Power Up Marker] for the time from the most recent power up. [Fault x Time] – [Power Up Marker] = Time difference to the most recent power up. A negative value indicates fault occurred before most recent power up. A positive value indicates fault occurred after most recent power up.				

File	Group	No.	Parameter Name & Description <i>See page 1-2 for symbol descriptions</i>	Values	Related
UTILITY	Alarms	259	[Alarm Config 1] Enables/disables alarm conditions that will initiate an active drive alarm. 1=Enabled 0=Disabled x=Reserved <i>* Vector firmware 3.001 & later</i> <i>Factory Default Bit Values</i>		
		261	[Alarm Clear] Resets all [Alarm 1-8 Code] parameters to zero.	Default: 0 "Ready" Options: 0 "Ready" 1 "Clr Alarm Que"	262 263 264 265 266 267 268 269
		262	[Alarm 1 Code]	Default: Read Only	261
		263	[Alarm 2 Code]	Min/Max: 0/65535	
		264	[Alarm 3 Code]	Units: 1	
		265	[Alarm 4 Code]		
		266	[Alarm 5 Code]		
		267	[Alarm 6 Code]		
		268	[Alarm 7 Code]		
269	[Alarm 8 Code]				
A code that represents a drive alarm. The codes will appear in the order they occur (first 4 alarms in – first 4 out alarm queue). A time stamp is not available with alarms.					
Scaled Blocks	Vector	476	[Scale1 In Value]	Default: 0.0	
		482	[Scale2 In Value]	Min/Max: –/+32000.0	
		488	[Scale3 In Value]	–/+32767.0 (v2.xxx)	
		494	[Scale4 In Value]	–/+32767.000 v3 (1)	
		Displays the value of the signal being sent to [ScaleX In Value] using a link. (1) Blocks 3 & 4 only.		Units: 0.1 0.001 v3	
		477	[Scale1 In Hi]	Default: 0.0	
		483	[Scale2 In Hi]	Min/Max: –/+32000.0	
		489	[Scale3 In Hi]	–/+32767.0 (v2.xxx)	
495	[Scale4 In Hi]	–/+32767.000 v3 (1)			
Scales the upper value of [ScaleX In Value]. (1) Blocks 3 & 4 only.		Units: 0.1 0.001 v3			



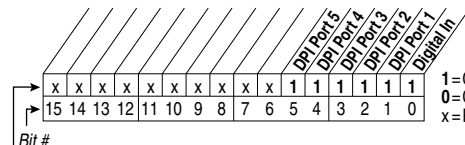

File	Group	No.	Parameter Name & Description <i>See page 1-2 for symbol descriptions</i>	Values	Related
UTILITY	Scaled Blocks	478	Vector [Scale1 In Lo]	Default: 0.0 Min/Max: -/+32000.0 -/+32767.0 (v2.xxx) -/+32767.000 v3 ⁽¹⁾ Units: 0.1 0.001 v3	
		484	Vector [Scale2 In Lo]		
		490	Vector v3 [Scale3 In Lo]		
		496	Vector v3 [Scale4 In Lo]		
		Scales the lower value of [ScaleX In Value]. (1) Blocks 3 & 4 only.			
		479	Vector [Scale1 Out Hi]	Default: 0.0 Min/Max: -/+32000.0 -/+32767.0 (v2.xxx) -/+32767.000 v3 ⁽¹⁾ Units: 0.1 0.001 v3	
		485	Vector [Scale2 Out Hi]		
		491	Vector v3 [Scale3 Out Hi]		
		497	Vector v3 [Scale4 Out Hi]		
		Scales the upper value of [ScaleX Out Value]. (1) Blocks 3 & 4 only.			
		480	Vector [Scale1 Out Lo]	Default: 0.0 Min/Max: -/+32000.0 -/+32767.0 (v2.xxx) -/+32767.000 v3 ⁽¹⁾ Units: 0.1 0.001 v3	
		486	Vector [Scale2 Out Lo]		
		492	Vector v3 [Scale3 Out Lo]		
		498	Vector v3 [Scale4 Out Lo]		
		Scales the lower value of [ScaleX Out Value]. (1) Blocks 3 & 4 only.			
		481	Vector [Scale1 Out Value]	Default: Read Only Min/Max: -/+32000.0 -/+32767.0 (v2.xxx) -/+32767.000 v3 ⁽¹⁾ Units: 0.1 0.001 v3	
487	Vector [Scale2 Out Value]				
493	Vector v3 [Scale3 Out Value]				
499	Vector v3 [Scale4 Out Value]				
Value of the signal being sent out of the Universal Scale block. Typically this value is used as the source of information and will be linked to another parameter. (1) Blocks 3 & 4 only.					

Communication File

File	Group	No.	Parameter Name & Description <i>See page 1-2 for symbol descriptions</i>	Values	Related																																																																					
COMMUNICATION	Comm Control	270	<p>Standard [DPI Data Rate]</p> <p>○ Sets the baud rate for attached drive peripherals. When changing this value the drive must be reset for the change to take affect.</p>	Default: 0 "125 kbps" Options: 0 "125 kbps" 1 "500 kbps"																																																																						
			<p>Vector [DPI Baud Rate]</p> <p>See description above.</p>	Default: 1 "500 kbps"																																																																						
		271	<p>[Drive Logic Rslt]</p> <p>The final logic command resulting from the combination of all DPI and discrete inputs. This parameter has the same structure as the product-specific logic command received via DPI and is used in peer to peer communications.</p>	Read Only																																																																						
			<p>Bit #</p> <table border="1"> <thead> <tr> <th>15</th><th>14</th><th>13</th><th>12</th><th>11</th><th>10</th><th>9</th><th>8</th><th>7</th><th>6</th><th>5</th><th>4</th><th>3</th><th>2</th><th>1</th><th>0</th> </tr> </thead> <tbody> <tr> <td>0</td><td>0</td><td>0</td><td>0</td><td>1</td><td>1</td><td>1</td><td>0</td><td>1</td><td>0</td><td>0</td><td>0</td><td>1</td><td>1</td><td>0</td><td>0</td> </tr> </tbody> </table> <p>1 = Condition True 0 = Condition False x = Reserved</p> <table border="1"> <thead> <tr> <th colspan="3">Bits⁽¹⁾</th> <th rowspan="2">Description</th> </tr> <tr> <th>14</th><th>13</th><th>12</th> </tr> </thead> <tbody> <tr><td>0</td><td>0</td><td>0</td><td>No Command - Man. Mode</td></tr> <tr><td>0</td><td>0</td><td>1</td><td>Ref A Auto</td></tr> <tr><td>0</td><td>1</td><td>0</td><td>Ref B Auto</td></tr> <tr><td>0</td><td>1</td><td>1</td><td>Preset 3 Auto</td></tr> <tr><td>1</td><td>0</td><td>0</td><td>Preset 4 Auto</td></tr> <tr><td>1</td><td>0</td><td>1</td><td>Preset 5 Auto</td></tr> <tr><td>1</td><td>1</td><td>0</td><td>Preset 6 Auto</td></tr> <tr><td>1</td><td>1</td><td>1</td><td>Preset 7 Auto</td></tr> </tbody> </table>	15	14	13	12	11	10	9	8	7	6	5	4	3	2	1	0	0	0	0	0	1	1	1	0	1	0	0	0	1	1	0	0	Bits ⁽¹⁾			Description	14	13	12	0	0	0	No Command - Man. Mode	0	0	1	Ref A Auto	0	1	0	Ref B Auto	0	1	1	Preset 3 Auto	1	0	0	Preset 4 Auto	1	0	1	Preset 5 Auto	1	1	0	Preset 6 Auto	1	1	1	Preset 7 Auto
15	14	13	12	11	10	9	8	7	6	5	4	3	2	1	0																																																											
0	0	0	0	1	1	1	0	1	0	0	0	1	1	0	0																																																											
Bits ⁽¹⁾			Description																																																																							
14	13	12																																																																								
0	0	0	No Command - Man. Mode																																																																							
0	0	1	Ref A Auto																																																																							
0	1	0	Ref B Auto																																																																							
0	1	1	Preset 3 Auto																																																																							
1	0	0	Preset 4 Auto																																																																							
1	0	1	Preset 5 Auto																																																																							
1	1	0	Preset 6 Auto																																																																							
1	1	1	Preset 7 Auto																																																																							
		272	<p>[Drive Ref Rslt]</p> <p>Present frequency reference scaled as a DPI reference for peer to peer communications. The value shown is the value prior to the accel/decel ramp and the corrections supplied by slip comp, PI, etc.</p>	Default: Read Only Min/Max: -/+32767 Units: 1																																																																						
		273	<p>[Drive Ramp Rslt]</p> <p>Present frequency reference scaled as a DPI reference for peer to peer communications. The value shown is the value after the accel/decel ramp, but prior to any corrections supplied by slip comp, PI, etc.</p>	Default: Read Only Min/Max: -/+32767 Units: 1																																																																						

File	Group	No.	Parameter Name & Description <i>See page 1-2 for symbol descriptions</i>	Values	Related
COMMUNICATION	Comm Control	274	Vector [DPI Port Sel] Selects which DPI port reference value will appear in [DPI Port Value].	Default: "DPI Port 1" Options: 1-5 "DPI Port 1-5"	
		275	Vector [DPI Port Value] Value of the DPI reference selected in [DPI Port Sel].	Default: Read Only Min/Max: -/+32767 Units: 1	
		298	Vector v3 [DPI Ref Select]  Scales DPI on maximum frequency or maximum speed.	Default: 0 "Max Freq" Options: 0 "Max Freq" 1 "Max Speed"	
		299	Vector v3 [DPI Fdbk Select] Selects DPI units displayed on the "Fdbk" line of the HIM. (1) Vector firmware 3.001 and later. (2) Refer to Input/Output Definitions on page 1-57 .	Default: 17 "Speed Fdbk" Options: 0 "Output Freq" 1 "Command Freq" 1(1) "Command Spd" 2 "Output Amps" 3 "Torque Amps" 4 "Flux Amps" 5 "Output Power" 6 "Output Volts" 7 "DC Bus Volts" 8 "PI Reference" ⁽²⁾ 9 "PI Feedback" 10 "PI Error" 11 "PI Output" 12 "%Motor OL" 13 "%Drive OL" 14 "CommandedTrq" 15 "MtrTrqCurRef" ⁽²⁾ 16 "Speed Ref" 17 "Speed Fdbk" 18 "Pulse In Ref" ⁽²⁾ 19 "Reserved" 20-23 "Scale Block1-4" ⁽¹⁾⁽²⁾	
		276	[Logic Mask]  Determines which adapters can control the drive. If the bit for an adapter is set to "0," the adapter will have no control functions except for stop.		288 thru 297
Masks & Owners	 <p>Bit #</p> <p>Factory Default Bit Values</p> <p>1 = Control Permitted 0 = Control Masked x = Reserved</p>				
	277	[Start Mask]  Controls which adapters can issue start commands.	See [Logic Mask] .	288 thru 297	

File	Group	No.	Parameter Name & Description <i>See page 1-2 for symbol descriptions</i>	Values	Related
COMMUNICATIONS	Masks & Owners	278	[Jog Mask] Controls which adapters can issue jog commands.	See [Logic Mask] .	288 thru 297
		279	[Direction Mask] Controls which adapters can issue forward/reverse direction commands.	See [Logic Mask] .	288 thru 297
		280	[Reference Mask] Controls which adapters can select an alternate reference; [Speed Ref A, B Sel] or [Preset Speed 1-7].	See [Logic Mask] .	288 thru 297
		281	[Accel Mask] Controls which adapters can select [Accel Time 1, 2].	See [Logic Mask] .	288 thru 297
		282	[Decel Mask] Controls which adapters can select [Decel Time 1, 2].	See [Logic Mask] .	288 thru 297
		283	[Fault Ctr Mask] Controls which adapters can clear a fault.	See [Logic Mask] .	288 thru 297
		284	[MOP Mask] Controls which adapters can issue MOP commands to the drive.	See [Logic Mask] .	288 thru 297
		285	[Local Mask] Controls which adapters are allowed to take exclusive control of drive logic commands (except stop). Exclusive "local" control can only be taken while the drive is stopped.	See [Logic Mask] .	288 thru 297
		288	[Stop Owner] Adapters that are presently issuing a valid stop command.	Read Only	276 thru 285
					<p>1=Issuing Command 0=No Command x=Reserved</p>
289	[Start Owner] Adapters that are presently issuing a valid start command.	See [Stop Owner] .	276 thru 285		
290	[Jog Owner] Adapters that are presently issuing a valid jog command.	See [Stop Owner] .	276 thru 285		

File	Group	No.	Parameter Name & Description <i>See page 1-2 for symbol descriptions</i>	Values	Related
COMMUNICATIONS	Masks & Owners	291	[Direction Owner] Adapter that currently has exclusive control of direction changes.	See [Stop Owner] .	276 thru 285
		292	[Reference Owner] Adapter that has the exclusive control of the command frequency source selection.	See [Stop Owner] .	276 thru 285
		293	[Accel Owner] Adapter that has exclusive control of selecting [Accel Time 1, 2].	See [Stop Owner] .	140 276 thru 285
		294	[Decel Owner] Adapter that has exclusive control of selecting [Decel Time 1, 2].	See [Stop Owner] .	142 276 thru 285
		295	[Fault Clr Owner] Adapter that is presently clearing a fault.	See [Stop Owner] .	276 thru 285
		296	[MOP Owner] Adapters that are currently issuing increases or decreases in MOP command frequency.	See [Stop Owner] .	276 thru 285
		297	[Local Owner] Adapter that has requested exclusive control of all drive logic functions. If an adapter is in local lockout, all other functions (except stop) on all other adapters are locked out and non-functional. Local control can only be obtained when the drive is not running.	See [Stop Owner] .	276 thru 285
		300 301	[Data In A1] - Link A Word 1 [Data In A2] - Link A Word 2  Parameter number whose value will be written from a communications device data table. Standard Control – Parameters that can only be changed while drive is stopped cannot be used as Datalink inputs. Entering a parameter of this type will "Disable" the link. Vector Control – Will not be updated until drive is stopped. Refer to your communications option manual for datalink information.	Default: 0 (0 = "Disabled") Min/Max: 0/387 0/544  0/611  Units: 1	
		302 303	[Data In B1] - Link B Word 1 [Data In B2] - Link B Word 2 	See [Data In A1] - Link A Word 1 [Data In A2] - Link A Word 2 .	

File	Group	No.	Parameter Name & Description <i>See page 1-2 for symbol descriptions</i>	Values	Related	
COMMUNICATIONS	Datalinks	304	[Data In C1] - Link C Word 1	See [Data In A1] - Link A Word 1 [Data In A2] - Link A Word 2 .		
		305	[Data In C2] - Link C Word 2			
			306	[Data In D1] - Link D Word 1		See [Data In A1] - Link A Word 1 [Data In A2] - Link A Word 2 .
		307	[Data In D2] - Link D Word 2			
			310	[Data Out A1] - Link A Word 1		Default: 0 (0 = "Disabled") Min/Max: 0/387 0/544 Vector 0/611 v3 Units: 1
		311	[Data Out A2] - Link A Word 2 Parameter number whose value will be written to a communications device data table.			
		312	[Data Out B1] - Link B Word 1	See [Data Out A1] - Link A Word 1 [Data Out A2] - Link A Word 2 .		
		313	[Data Out B2] - Link B Word 2			
		314	[Data Out C1] - Link C Word 1	See [Data Out A1] - Link A Word 1 [Data Out A2] - Link A Word 2 .		
		315	[Data Out C2] - Link C Word 2			
316	[Data Out D1] - Link D Word 1	See [Data Out A1] - Link A Word 1 [Data Out A2] - Link A Word 2 .				
317	[Data Out D2] - Link D Word 2					

Inputs & Outputs File

File	Group	No.	Parameter Name & Description <i>See page 1-2 for symbol descriptions</i>	Values	Related
INPUTS & OUTPUTS	Analog Inputs	320	[Anlg In Config] Selects the mode for the analog inputs.	<p>1 = Current 0 = Voltage x = Reserved</p> <p>Factory Default Bit Values</p>	322 325 323 326
		321	[Anlg In Sqr Root] Enables/disables the square root function for each input.		<p>1 = Enable 0 = Disable x = Reserved</p> <p>Factory Default Bit Values</p>

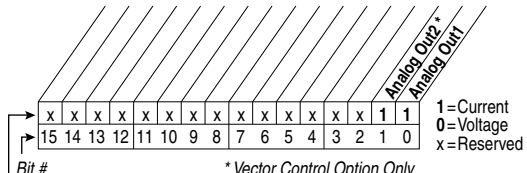
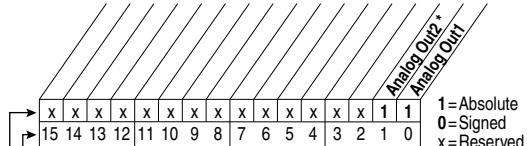
File	Group	No.	Parameter Name & Description <i>See page 1-2 for symbol descriptions</i>	Values	Related
INPUTS & OUTPUTS	Analog Inputs	322	[Analog In 1 Hi]	Default: 10.000 Volt	091 092
		325	[Analog In 2 Hi] Sets the highest input value to the analog input x scaling block. [Anlg In Config], parameter 320 defines if this input will be $\pm 10V$ or 4-20 mA (0-20 mA with Vector firmware 3.xxx & later).	Min/Max: 4.000/20.000mA 0.000/20.000mA v3 $\pm 10.000V$ 0.000/10.000V Units: 0.001 mA 0.001 Volt	
		323	[Analog In 1 Lo]	Default: 0.000 Volt	
		326	[Analog In 2 Lo] Sets the lowest input value to the analog input x scaling block. [Anlg In Config], parameter 320 defines if this input will be $\pm 10V$ or 4-20 mA (0-20 mA with Vector firmware 3.xxx & later). If set below 4 mA, [Analog In x Loss] should be "Disabled."	Min/Max: 4.000/20.000mA 0.000/20.000mA v3 $\pm 10.000V$ 0.000/10.000V Units: 0.001 mA 0.001 Volt	
		324	[Analog In 1 Loss]	Default: 0 "Disabled"	
327	[Analog In 2 Loss] Selects drive action when an analog signal loss is detected. Signal loss is defined as an analog signal less than 1V or 2mA. The signal loss event ends and normal operation resumes when the input signal level is greater than or equal to 1.5V or 3mA.	Options: 0 "Disabled" 1 "Fault" 2 "Hold Input" 3 "Set Input Lo" 4 "Set Input Hi" 5 "Goto Preset1" 6 "Hold OutFreq"	091 092		
Analog Outputs	Analog Outputs	340	[Anlg Out Config] Selects the mode for the analog outputs.  <p style="text-align: right;">1 = Current 0 = Voltage x = Reserved</p> <p style="text-align: center;">* Vector Control Option Only</p> <p>Factory Default Bit Values</p>		
		341	[Anlg Out Absolut] Selects whether the signed value or absolute value of a parameter is used before being scaled to drive the analog output.  <p style="text-align: right;">1 = Absolute 0 = Signed x = Reserved</p> <p style="text-align: center;">* Vector Control Option Only</p> <p>Factory Default Bit Values</p>		

File	Group	No.	Parameter Name & Description <i>See page 1-2 for symbol descriptions</i>	Values	Related		
INPUTS & OUTPUTS	Analog Outputs	342	[Analog Out1 Sel]	Default: 0 "Output Freq"	001		
		345	Vector [Analog Out2 Sel] Selects the source of the value that drives the analog output.	Options: See Table	002 003 004 005 007 006 012 135 136 137 138 220 219		
				Options	[Analog Out1 Lo] Value	[Analog Out1 Hi] Value	
					<i>Param. 341 = Signed</i>	<i>Param. 341 = Absolute</i>	
		0	"Output Freq"	–[Maximum Speed]	0 Hz	+[Maximum Speed]	
		1	"Command Freq"	–[Maximum Speed]	0 Hz	+[Maximum Speed]	
		1*	"Command Spd"	–[Maximum Speed]	0 Hz/RPM	+[Maximum Speed]	
		2	"Output Amps"	0 Amps	0 Amps	200% Rated	
		3	"Torque Amps"	–200% Rated	0 Amps	200% Rated	
		4	"Flux Amps"	0 Amps	0 Amps	200% Rated	
5	"Output Power"	0 kW	0 kW	200% Rated			
6	"Output Volts"	0 Volts	0 Volts	120% Rated Input Volts			
7	"DC Bus Volts"	0 Volts	0 Volts	200% Rated Input Volts			
8	"PI Reference" ⁽¹⁾	–100%	0%	100%			
9	"PI Feedback"	–100%	0%	100%			
10	"PI Error"	–100%	0%	100%			
11	"PI Output"	–100%	0%	100%			
12	"%Motor OL"	0%	0%	100%			
13	"%Drive OL"	0%	0%	100%			
14*	"CommandedTrq"	–800% Rated	0%	800% Rated			
15*	"MtrTrqCurRef" ⁽¹⁾	–200% Rated	0%	200% Rated			
16*	"Speed Ref"	–[Maximum Speed]	0 Hz/RPM	+[Maximum Speed]			
17*	"Speed Fdbk"	–[Maximum Speed]	0 Hz/RPM	+[Maximum Speed]			
18*	"Pulse In Ref" ⁽¹⁾	–25200.0 RPM	0 Hz/RPM	+[Maximum Speed]			
19*	"Torque Est" ⁽¹⁾	–800%	0%	+800%			
20-23*	"Scale Block1-4" ⁽¹⁾						
24*	"Param Cnt" ⁽¹⁾				377 378		
		* Vector Control Option Only **Vector firmware 3.001 & later					
		⁽¹⁾ Refer to Option Definitions on page 1-57 .					
343		[Analog Out1 Hi]	Default: 20.000 mA, 10.000 Volts	340			
346	Vector [Analog Out2 Hi] Sets the analog output value when the source value is at maximum.		Min/Max: 4.000/20.000mA 0.000/20.000mA v3 –/+10.000V Units: 0.001 mA 0.001 Volt	342			
344		[Analog Out1 Lo]	Default: 0.000 mA, 0.000 Volts	340			
347	Vector [Analog Out2 Lo] Sets the analog output value when the source value is at minimum.		Min/Max: 4.000/20.000mA 0.000/20.000mA v3 –/+10.000V Units: 0.001 mA 0.001 Volt	342			

File	Group	No.	Parameter Name & Description <i>See page 1-2 for symbol descriptions</i>	Values	Related
INPUTS & OUTPUTS	Analog Outputs	354	Vector v3 [Anlg Out1 Scale]	Default: 0.0	
		355	Vector v3 [Anlg Out2 Scale]	Min/Max: [Analog Out1 Sel] Units: 0.01	
		Sets the high value for the range of analog out scale. Entering 0.0 will disable this scale and max scale will be used. Example: If [Analog Out Sel] = "Commanded Trq," a value of 150 = 150% scale in place of the default 800%.			
		377	Vector v3 [Anlg1 Out Setpt]	Default: 20.000 mA, 10.000 Volts	
		378	Vector v3 [Anlg2 Out Setpt]	Min/Max: 0.000/20.000mA -/+10.000V Units: 0.001 mA 0.001 Volt	
			Sets the analog output value from a communication device. Example: Set [Data In Ax] to "377" (value from communication device). Then set [Analog Outx Sel] to "Param Cntl."		

Selected Option Definitions – [Analog Outx Sel], [Digital Inx Sel], [Digital Outx Sel]

Option	Description	Related
At Speed	Relay changes state when drive has reached commanded speed.	380
Fast Stop	When open, the drive will stop with a 0.1 second decel time. (If Torque Proving is being used, float will be ignored at end of ramp and the mechanical brake will be set).	361
Excl Link	Links digital input to a digital output if the output is set to "Input 1-6 Link." This does not need to be selected in the Vector option.	361
Input 1-6 Link	When Digital Output 1 is set to one of these (i.e. Input 3 Link) in conjunction with Digital Input 3 set to "Excl Link," the Digital Input 3 state (on/off) is echoed in the Digital Output 1.	380
Micro Pos	Microposition input. When closed, the command frequency is set to a percentage speed reference as defined in [MicroPos Scale%], parameter 611.	361
MOP Dec	Decrements speed reference as long as input is closed.	361
MOP Inc	Increments speed reference as long as input is closed.	361
MtrTrqCurRef	Torque producing current reference.	342
Param Cntl	Parameter controlled analog output allows PLC to control analog outputs through data links. Set in [AnlgX Out Setpt], parameters 377-378.	342
Param Cntl	Parameter controlled digital output allows PLC to control digital outputs through data links. Set in [Dig Out Setpt], parameter 379.	380
PI Reference	Reference for PI block (see Process PI for Standard Control on page C-13).	342
Precharge En	Forces drive into precharge state. Typically controlled by auxiliary contact on the disconnect at the DC input to the drive.	361
Pulse In Ref	Reference of the pulse input (Z channel of encoder - can be used while A & B channels are encoder inputs).	342
Scale Block 1-4	Output of scale blocks, parameters 354-355.	342
Torque Est	Calculated percentage of rated motor torque.	342
Torque Setpt 1	Selects "Torque Stpt1" for [Torque Ref A Sel] when set, otherwise uses value selected in [Torque Ref A Sel].	361

File	Group	No.	Parameter Name & Description	Values	Related																																					
INPUTS & OUTPUTS	Digital Inputs	361	[Digital In1 Sel]	Default: 4																																						
		362	[Digital In2 Sel]	Default: 5																																						
		363	[Digital In3 Sel]	Default: 18																																						
		364	[Digital In4 Sel]	Default: 15																																						
		365	[Digital In5 Sel]	Default: 16																																						
		366	[Digital In6 Sel] ⁽¹¹⁾	Default: 17																																						
		 Selects the function for the digital inputs.		Options: 0		“Not Used”																																				
		(1) Speed Select Inputs.		1		“Enable” ^(8, 10)																																				
		<table border="1" style="width: 100%; border-collapse: collapse;"> <thead> <tr> <th>3</th> <th>2</th> <th>1</th> <th>Auto Reference Source</th> </tr> </thead> <tbody> <tr><td>0</td><td>0</td><td>0</td><td>Reference A</td></tr> <tr><td>0</td><td>0</td><td>1</td><td>Reference B</td></tr> <tr><td>0</td><td>1</td><td>0</td><td>Preset Speed 2</td></tr> <tr><td>0</td><td>1</td><td>1</td><td>Preset Speed 3</td></tr> <tr><td>1</td><td>0</td><td>0</td><td>Preset Speed 4</td></tr> <tr><td>1</td><td>0</td><td>1</td><td>Preset Speed 5</td></tr> <tr><td>1</td><td>1</td><td>0</td><td>Preset Speed 6</td></tr> <tr><td>1</td><td>1</td><td>1</td><td>Preset Speed 7</td></tr> </tbody> </table>		3		2	1	Auto Reference Source	0	0	0	Reference A	0	0	1	Reference B	0	1	0	Preset Speed 2	0	1	1	Preset Speed 3	1	0	0	Preset Speed 4	1	0	1	Preset Speed 5	1	1	0	Preset Speed 6	1	1	1	Preset Speed 7	2	“Clear Faults”(CF) ⁽⁴⁾
		3	2	1		Auto Reference Source																																				
		0	0	0		Reference A																																				
		0	0	1		Reference B																																				
		0	1	0		Preset Speed 2																																				
		0	1	1		Preset Speed 3																																				
1	0	0	Preset Speed 4																																							
1	0	1	Preset Speed 5																																							
1	1	0	Preset Speed 6																																							
1	1	1	Preset Speed 7																																							
To access Preset Speed 1, set [Speed Ref x Sel] to “Preset Speed 1”.		3	“Aux Fault”																																							
Type 2 Alarms - Some digital input programming may cause conflicts that will result in a Type 2 alarm. Example: [Digital In1 Sel] set to “5, Start” in 3-wire control and [Digital In2 Sel] set to 7 “Run” in 2-wire. See Table 2.C for info on resolving this type of conflict.		4	“Stop – CF” ⁽¹⁰⁾																																							
(2) Vector Control Option Only.		5	“Start” ^(5, 9)																																							
(3)		6	“Fwd/ Reverse” ⁽⁵⁾																																							
<table border="1" style="width: 100%; border-collapse: collapse;"> <thead> <tr> <th>3</th> <th>2</th> <th>1</th> <th>Spd/Trq Mode</th> </tr> </thead> <tbody> <tr><td>0</td><td>0</td><td>0</td><td>Zero Torque</td></tr> <tr><td>0</td><td>0</td><td>1</td><td>Spd Reg</td></tr> <tr><td>0</td><td>1</td><td>0</td><td>Torque Reg</td></tr> <tr><td>0</td><td>1</td><td>1</td><td>Min Spd/Trq</td></tr> <tr><td>1</td><td>0</td><td>0</td><td>Max Spd/Trq</td></tr> <tr><td>1</td><td>0</td><td>1</td><td>Sum Spd/Trq</td></tr> <tr><td>1</td><td>1</td><td>0</td><td>Absolute</td></tr> <tr><td>1</td><td>1</td><td>1</td><td>Zero Trq</td></tr> </tbody> </table>		3	2	1	Spd/Trq Mode	0	0	0	Zero Torque	0	0	1	Spd Reg	0	1	0	Torque Reg	0	1	1	Min Spd/Trq	1	0	0	Max Spd/Trq	1	0	1	Sum Spd/Trq	1	1	0	Absolute	1	1	1	Zero Trq	7	“Run” ^(6, 10)			
3	2	1	Spd/Trq Mode																																							
0	0	0	Zero Torque																																							
0	0	1	Spd Reg																																							
0	1	0	Torque Reg																																							
0	1	1	Min Spd/Trq																																							
1	0	0	Max Spd/Trq																																							
1	0	1	Sum Spd/Trq																																							
1	1	0	Absolute																																							
1	1	1	Zero Trq																																							
(4) When [Digital Inx Sel] is set to option 2 “Clear Faults” the Stop button cannot be used to clear a fault condition.		8	“Run Forward” ⁽⁶⁾																																							
(5) Typical 3-Wire Inputs - Only 3-wire functions are allowed. Including 2-wire selections will cause a type 2 alarm.		9	“Run Reverse” ⁽⁶⁾																																							
(6) Typical 2-Wire Inputs - Requires that only 2-wire functions are chosen. Including 3-wire selections will cause a type 2 alarm. See Table 2.C for conflicts.		10	“Jog” ⁽⁵⁾ “Jog1” ⁽²⁾																																							
(7) Auto/Manual - Refer to Reference Control in the Installation Instructions for details.		11	“Jog Forward” ⁽⁶⁾																																							
(8) Opening an “Enable” input will cause the motor to coast-to-stop, ignoring any programmed Stop modes.		12	“Jog Reverse” ⁽⁶⁾																																							
(9) “Dig In ConflictB” alarm will occur if a “Start” input is programmed without a “Stop” input.		13	“Stop Mode B”																																							
(10) Refer to the Sleep-Wake Mode Attention statement on page 1-36 .		14	“Bus Reg Md B”																																							
(11) A dedicated hardware enable input is available via a jumper selection. Refer to the Installation Instructions for further information.		15-17	“Speed Sel 1-3” ⁽¹⁾																																							
(12) Vector firmware 3.001 and later.		18	“Auto/ Manual” ⁽⁷⁾																																							
(13) Only available when “Torque Proving” function is selected.		19	“Local”																																							
(14) Refer to Option Definitions on page 1-57 .		20	“Acc2 & Dec2”																																							
		21	“Accel 2”																																							
		22	“Decel 2”																																							
		23	“MOP Inc” ⁽¹⁴⁾																																							
		24	“MOP Dec” ⁽¹⁴⁾																																							
		25	“Excl Link” ⁽¹⁴⁾																																							
		26	“PI Enable”																																							
		27	“PI Hold”																																							
		28	“PI Reset”																																							
		29	“Pwr Loss Lvl”																																							
		30	“Precharge En” ⁽¹⁴⁾																																							
		31-33	“Spd/Trq Sel1-3” ^(2,3)																																							
		34	“Jog 2” ⁽²⁾																																							
		35	“PI Invert” ⁽¹²⁾																																							
		36	“Torque Setpt 1” ^(12, 14)																																							
		37	“Micro Pos” ^(12, 13, 14)																																							
		38	“Fast Stop” ^(12, 14)																																							

[100](#)

[156](#)

[162](#)

[096](#)

[141](#)

[143](#)

[195](#)

[194](#)

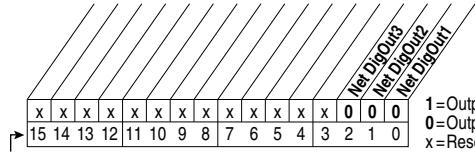

[380](#)

[124](#)

File	Group	No.	Parameter Name & Description <i>See page 1-2 for symbol descriptions</i>	Values	Related
INPUTS & OUTPUTS	Digital Outputs	379	Vector v3 [Dig Out Setpt] Sets the digital output value from a communication device. Example Set [Data In B1] to "379." The first three bits of this value will determine the setting of [Digital Outx Sel] which should be set to "30, Param Cntl."  <p>Bit #</p> <p>1 = Output Energized 0 = Output De-energized x = Reserved</p>		380
		380	[Digital Out1 Sel] ⁽⁵⁾	Default: 1 "Fault"	381
		384	[Digital Out2 Sel]	4 "Run"	385
		388	Vector [Digital Out3 Sel] Selects the drive status that will energize a (CRx) output relay. (1) Any relay programmed as Fault or Alarm will energize (pick up) when power is applied to drive and deenergize (drop out) when a fault or alarm exists. Relays selected for other functions will energize only when that condition exists and will deenergize when condition is removed. (2) Vector Control Option Only. (3) Activation level is defined in [Dig Outx Level] below. (4) Vector firmware 3.001 and later. (5) When [TorqProve Cnfg] is set to "Enable," [Digital Out1 Sel] becomes the brake control and any other selection will be ignored. (6) Refer to Option Definitions on page 1-57 .	Options: 1 "Fault" ⁽¹⁾ 2 "Alarm" ⁽¹⁾ 3 "Ready" 4 "Run" 5 "Forward Run" 6 "Reverse Run" 7 "Auto Restart" 8 "Powerup Run" 9 "At Speed" ⁽⁶⁾ 10 "At Freq" ⁽³⁾ 11 "At Current" ⁽³⁾ 12 "At Torque" ⁽³⁾ 13 "At Temp" ⁽³⁾ 14 "At Bus Volts" ⁽³⁾ 15 "At PI Error" ⁽³⁾ 16 "DC Braking" 17 "Curr Limit" 18 "Economize" 19 "Motor Overld" 20 "Power Loss" 21-26 "Input 1-6 Link" ⁽⁶⁾ 27 "PI Enable" ⁽²⁾ 28 "PI Hold" ⁽²⁾ 29 "Drive Overload" ⁽²⁾ 30 "Param Cntl" ^(4, 6)	389 382 386 390 383 002 001 003 004 218 012 137 157 147 053 048 184 379
381	[Dig Out1 Level]	Default: 0.0	380		
385	[Dig Out2 Level]	0.0			
389	Vector [Dig Out3 Level] Sets the relay activation level for options 10-15 in [Digital Outx Sel]. Units are assumed to match the above selection (i.e. "At Freq" = Hz, "At Torque" = Amps).	Min/Max: 0.0/819.2 Units: 0.1			

File	Group	No.	Parameter Name & Description <i>See page 1-2 for symbol descriptions</i>	Values	Related
INPUTS & OUTPUTS	Digital Outputs	382	[Dig Out1 OnTime]	Default: 0.00 Secs	380
		386	[Dig Out2 OnTime]	0.00 Secs	
		390	Vector [Dig Out3 OnTime]	Min/Max: 0.00/600.00 Secs	
			Sets the “ON Delay” time for the digital outputs. This is the time between the occurrence of a condition and activation of the relay.	Units: 0.01 Secs	
		383	[Dig Out1 OffTime]	Default: 0.00 Secs	380
	387	[Dig Out2 OffTime]	0.00 Secs		
	391	Vector [Dig Out3 OffTime]	Min/Max: 0.00/600.00 Secs		
			Sets the “OFF Delay” time for the digital outputs. This is the time between the disappearance of a condition and de-activation of the relay.	Units: 0.01 Secs	

Applications File

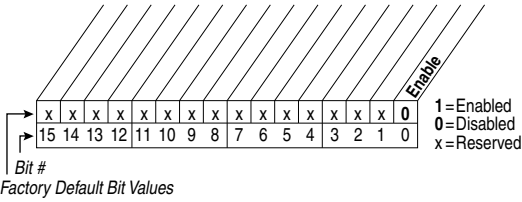
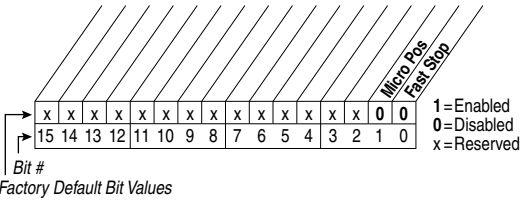
File	Group	No.	Parameter Name & Description <i>See page 1-2 for symbol descriptions</i>	Values	Related
Applications	Torque Proving	600	Vector v3 [TorqProve Cnfg]		
			Enables/disables torque/brake proving feature. When “Enabled,” [Digital Out1 Sel] becomes the brake control. Note: this value is not changed when parameters are reset to factory defaults (page 1-40).	 <p>Bit # Factory Default Bit Values</p>	
		601	Vector v3 [TorqProve Setup]		
			Allows control of specific torque proving functions through a communication device.	 <p>Bit # Factory Default Bit Values</p>	

File	Group	No.	Parameter Name & Description <i>See page 1-2 for symbol descriptions</i>	Values	Related
Applications	Torque Proving	602	Vector v3 [Spd Dev Band] Defines the allowable difference between the commanded frequency and encoder feedback value. A fault will occur when the difference exceeds this value for a period of time.	Default: 2.0 Hz 60.0 RPM Min/Max: 0.1/15.0 Hz 3.0/450.0 RPM Units: 0.1 Hz 0.1 RPM	603
		603	Vector v3 [SpdBand Integrat] Sets the amount of time before a fault is issued when [Spd Dev Band] is outside its threshold.	Default: 60 mSec Min/Max: 1/200 mSec Units: 1 mSec	602
		604	Vector v3 [Brk Release Time] Sets the amount of time between commanding the brake to release and the start of frequency acceleration.	Default: 0.10 Secs Min/Max: 0.00/10.00 Secs Units: 0.01 Secs	
		605	Vector v3 [ZeroSpdFloatTime] Sets the amount of time the drive is below [Float Tolerance] before the brake is set.	Default: 5.0 Secs Min/Max: 0.1/500.0 Secs Units: 0.1 Secs	
		606	Vector v3 [Float Tolerance] Sets the frequency level where the float timer starts.	Default: 0.2 Hz 6.0 RPM Min/Max: 0.1/5.0 Hz 3.0/150.0 RPM Units: 0.1 Hz 0.1 RPM	
		607	Vector v3 [Brk Set Time] Defines the amount of delay time between commanding the brake to be set and the start of brake proving.	Default: 0.10 Secs Min/Max: 0.00/10.00 Secs Units: 0.01 Secs	
		608	Vector v3 [TorqLim SlewRate] Sets the rate to ramp the torque limits to zero during brake proving.	Default: 10.0 Secs Min/Max: 0.5/300.0 Secs Units: 0.1 Secs	
		609	Vector v3 [BrkSlip Count] Sets the number of encoder counts to define a brake slippage condition.	Default: 250 Min/Max: 0/65535 Units: 1	
		610	Vector v3 [Brk Alarm Travel] Sets the number of motor shaft revolutions allowed during the brake slippage test. Drive torque is reduced to check for brake slippage. When slippage occurs, the drive allows this number of motor shaft revolutions before regaining control.	Default: 1.0 Revs Min/Max: 0.0/1000.0 Revs Units: 0.1 Revs	
		611	Vector v3 [MicroPos Scale%] Sets the percent of speed reference to be used when micropositioning has been selected. Motor must come to a stop before this setting will take effect.	Default: 10.0% Min/Max: 0.1/100.0% Units: 0.1%	361 thru 366

Parameter Cross Reference – by Name

Parameter Name	Number	Group	Page
Accel Mask	281	Masks & Owners	1-52
Accel Owner	293	Masks & Owners	1-53
Accel Time X	140, 141	Ramp Rates	1-31
Alarm Clear	261	Alarms	1-48
Alarm Config 1	259	Alarms	1-48
Alarm X @ Fault	229, 230	Diagnostics	1-45
Alarm X Code	262-269	Alarms	1-48
Analog In X Hi	322, 325	Analog Inputs	1-55
Analog In X Lo	323, 326	Analog Inputs	1-55
Analog In X Loss	324, 327	Analog Inputs	1-55
Analog In1 Value	16	Metering	1-13
Analog In2 Value	17	Metering	1-13
Analog OutX Hi	343, 346	Analog Outputs	1-56
Analog OutX Lo	344, 347	Analog Outputs	1-56
Analog OutX Sel	342, 345	Analog Outputs	1-56
Anlg In Config	320	Analog Inputs	1-54
Anlg In Sqr Root	321	Analog Inputs	1-54
Anlg Out Absolut	341	Analog Outputs	1-55
Anlg Out Config	340	Analog Outputs	1-55
Anlg OutX Scale	354, 355	Analog Outputs	1-57
Anlg OutX Setpt	377, 378	Analog Outputs	1-57
Auto Rstrt Delay	175	Restart Modes	1-35
Auto Rstrt Tries	174	Restart Modes	1-35
Autotune	61	Torq Attributes	1-17
Autotune Torque	66	Torq Attributes	1-18
Break Frequency	72	Volts per Hertz	1-20
Break Voltage	71	Volts per Hertz	1-20
Brk Release Time	604	Torq Proving	1-61
Brk Set Time	607	Torq Proving	1-61
Brk Alarm Travel	610	Torq Proving	1-61
BrkSlip Count	609	Torq Proving	1-61
Bus Reg Kd	165	Stop/Brake Modes	1-34
Bus Reg Ki	160	Stop/Brake Modes	1-33
Bus Reg Kp	164	Stop/Brake Modes	1-34
Bus Reg Mode X	161, 162	Stop/Brake Modes	1-33
Commanded Freq	2	Metering	1-12
Commanded Speed	2	Metering	1-12
Commanded Torque	24	Metering	1-13
Compensation	56	Torq Attributes	1-16
Control Status	440	Torq Attributes	1-19
Control SW Ver	29	Drive Data	1-14
Current Lmt Gain	149	Load Limits	1-31
Current Lmt Sel	147	Load Limits	1-31
Current Lmt Val	148	Load Limits	1-31
Current Rate Limit	154	Load Limits	1-32
Data In XX	300-307	Datalinks	1-53
Data Out XX	310-317	Datalinks	1-54
DB Resistor Type	163	Stop/Brake Modes	1-34
DB While Stopped	145	Stop/Brake Modes	1-32
DC Brake Level	158	Stop/Brake Modes	1-33
DC Brake Time	159	Stop/Brake Modes	1-33
DC Brk Lvl Sel	157	Stop/Brake Modes	1-32
DC Bus Memory	13	Metering	1-13
DC Bus Voltage	12	Metering	1-13
Decel Mask	282	Masks & Owners	1-52

Parameter Name	Number	Group	Page
Decel Owner	294	Masks & Owners	1-53
Decel Time X	142, 143	Ramp Rates	1-31
Dig In Status	216	Diagnostics	1-44
Dig Out Setpt	379	Digital Outputs	1-59
Dig Out Status	217	Diagnostics	1-44
Dig OutX Level	381, 385, 389	Digital Outputs	1-59
Dig OutX OffTime	383, 387, 391	Digital Outputs	1-60
Dig OutX OnTime	382, 386, 390	Digital Outputs	1-60
Digital InX Sel	361-366	Digital Inputs	1-58
Digital OutX Sel	380, 384, 388	Digital Outputs	1-59
Direction Mask	279	Masks & Owners	1-52
Direction Mode	190	Direction Config	1-38
Direction Owner	291	Masks & Owners	1-53
DPI Baud Rate	270	Comm Control	1-50
DPI Data Rate	270	Comm Control	1-50
DPI Fdbk Select	299	Comm Control	1-51
DPI Port Sel	274	Comm Control	1-51
DPI Port Value	275	Comm Control	1-51
DPI Ref Select	298	Comm Control	1-51
Drive Alarm X	211, 212	Diagnostics	1-42
Drive Checksum	203	Drive Memory	1-41
Drive Logic Rslt	271	Comm Control	1-50
Drive OL Count	219	Diagnostics	1-44
Drive OL Mode	150	Load Limits	1-31
Drive Ramp Rslt	273	Comm Control	1-50
Drive Ref Rslt	272	Comm Control	1-50
Drive Status X	209, 210	Diagnostics	1-41
Drive Temp	218	Diagnostics	1-44
Droop RPM @ FLA	152	Load Limits	1-32
Elapsed kWh	014	Metering	1-13
Elapsed MWh	9	Metering	1-12
Elapsed Run Time	10	Metering	1-12
Enc Position Fdbk	414	Speed Feedback	1-20
Encoder PPR	413	Speed Feedback	1-20
Encoder Speed	415	Speed Feedback	1-20
Encoder Z Chan	423	Speed Feedback	1-21
Fault 1 Code	243	Faults	1-47
Fault 1 Time	244	Faults	1-47
Fault 2 Code	245	Faults	1-47
Fault 2 Time	246	Faults	1-47
Fault 3 Code	247	Faults	1-47
Fault 3 Time	248	Faults	1-47
Fault 4 Code	249	Faults	1-47
Fault 4 Time	250	Faults	1-47
Fault 5 Code	251	Faults	1-47
Fault 5 Time	252	Faults	1-47
Fault 6 Code	253	Faults	1-47
Fault 6 Time	254	Faults	1-47
Fault 7 Code	255	Faults	1-47
Fault 7 Time	256	Faults	1-47
Fault 8 Code	257	Faults	1-47
Fault 8 Time	258	Faults	1-47

Parameter Name	Number	Group	Page
Fault Amps	225	Diagnostics	1-44
Fault Bus Volts	226	Diagnostics	1-45
Fault Clear	240	Faults	1-46
Fault Clear Mode	241	Faults	1-47
Fault Clr Mask	283	Masks & Owners	1-52
Fault Clr Owner	295	Masks & Owners	1-53
Fault Config 1	238	Faults	1-46
Fault Frequency	224	Diagnostics	1-44
Fault Speed	224	Diagnostics	1-44
Fdbk Filter Sel	416	Speed Feedback	1-20
Feedback Select	80	Spd Mode & Limits	1-22
Float Tolerance	606	Torq Proving	1-61
Flux Braking	166	Stop/Brake Modes	1-34
Flux Current	5	Metering	1-12
Flux Current Ref	63	Torq Attributes	1-17
Flux Up Mode	57	Torq Attributes	1-16
Flux Up Time	58	Torq Attributes	1-16
Flying Start En	169	Restart Modes	1-35
Flying StartGain	170	Restart Modes	1-35
Gnd Warn Level	177	Power Loss	1-37
Inertia Autotune	67	Torq Attributes	1-18
IR Voltage Drop	62	Torq Attributes	1-17
Ixo Voltage Drop	64	Torq Attributes	1-17
Jog Mask	278	Masks & Owners	1-52
Jog Owner	290	Masks & Owners	1-52
Jog Speed	100	Discrete Speeds	1-25
Jog Speed 1	100	Discrete Speeds	1-25
Jog Speed 2	108	Discrete Speeds	1-25
Kf Speed Loop	447	Speed Regulator	1-30
Ki Speed Loop	445	Speed Regulator	1-29
Kp Speed Loop	446	Speed Regulator	1-30
Language	201	Drive Memory	1-40
Last Stop Source	215	Diagnostics	1-43
Load Frm Usr Set	198	Drive Memory	1-40
Load Loss Level	187	Power Loss	1-38
Load Loss Time	188	Power Loss	1-38
Local Mask	285	Masks & Owners	1-52
Local Owner	297	Masks & Owners	1-53
Logic Mask	276	Masks & Owners	1-51
Man Ref Preload	193	HIM Ref Config	1-39
Marker Pulse	421	Speed Feedback	1-21
Maximum Freq	55	Torq Attributes	1-16
Maximum Speed	82	Spd Mode & Limits	1-22
Maximum Voltage	54	Torq Attributes	1-15
MicroPos Scale%	611	Torq Proving	1-61
Minimum Speed	81	Spd Mode & Limits	1-22
MOP Frequency	11	Metering	1-13
MOP Mask	284	Masks & Owners	1-52
MOP Owner	296	Masks & Owners	1-53
MOP Rate	195	MOP Config	1-39
MOP Reference	11	Metering	1-13
Motor Cntl Sel	53	Torq Attributes	1-15
Motor Fdbk Type	412	Speed Feedback	1-20
Motor NP FLA	42	Motor Data	1-14
Motor NP Hertz	43	Motor Data	1-14
Motor NP Power	45	Motor Data	1-15
Motor NP RPM	44	Motor Data	1-14
Motor NP Volts	41	Motor Data	1-14
Motor OL Count	220	Diagnostics	1-44

Parameter Name	Number	Group	Page
Motor OL Factor	48	Motor Data	1-15
Motor OL Hertz	47	Motor Data	1-15
Motor Poles	49	Motor Data	1-15
Motor Type	40	Motor Data	1-14
Mtr NP Pwr Units	46	Motor Data	1-15
Mtr Tor Cur Ref	441	Torq Attributes	1-19
Neg Torque Limit	437	Torq Attributes	1-19
Notch Filter Freq	419	Speed Feedback	1-20
Notch Filter K	420	Speed Feedback	1-21
Output Current	3	Metering	1-12
Output Freq	1	Metering	1-12
Output Power	7	Metering	1-12
Output Powr Fctr	8	Metering	1-12
Output Voltage	6	Metering	1-12
Overspeed Limit	83	Spd Mode & Limits	1-22
Param Access Lvl	196	Drive Memory	1-39
PI BW Filter	139	Process PI	1-29
PI Configuration	124	Process PI	1-27
PI Control	125	Process PI	1-27
PI Deriv Time	459	Process PI	1-29
PI Error Meter	137	Process PI	1-29
PI Fdbk Meter	136	Process PI	1-28
PI Feedback Hi	462	Process PI	1-29
PI Feedback Lo	463	Process PI	1-29
PI Feedback Sel	128	Process PI	1-28
PI Integral Time	129	Process PI	1-28
PI Lower Limit	131	Process PI	1-28
PI Output Meter	138	Process PI	1-29
PI Preload	133	Process PI	1-28
PI Prop Gain	130	Process PI	1-28
PI Ref Meter	135	Process PI	1-28
PI Reference Hi	460	Process PI	1-29
PI Reference Lo	461	Process PI	1-29
PI Reference Sel	126	Process PI	1-27
PI Setpoint	127	Process PI	1-27
PI Status	134	Process PI	1-28
PI Upper Limit	132	Process PI	1-28
Pos Torque Limit	436	Torq Attributes	1-19
Power Loss Level	186	Power Loss	1-38
Power Loss Mode	184	Power Loss	1-37
Power Loss Time	185	Power Loss	1-37
Power Up Marker	242	Faults	1-47
Powerup Delay	167	Restart Modes	1-34
Preset Speed X	101-107	Discrete Speeds	1-25
Pulse In Scale	422	Speed Feedback	1-21
Pulse Input Ref	99	Speed Reference	1-25
PWM Frequency	151	Load Limits	1-31
Ramped Speed	22	Metering	1-13
Rated Amps	28	Drive Data	1-14
Rated kW	26	Drive Data	1-14
Rated Volts	27	Drive Data	1-14
Reference Mask	280	Masks & Owners	1-52
Reference Owner	292	Masks & Owners	1-53
Regen Power Limit	153	Load Limits	1-32
Reset Meters	200	Drive Memory	1-40
Reset To Defaults	197	Drive Memory	1-40
Rev Speed Limit	454	Speed Regulator	1-23
Run Boost	70	Volts per Hertz	1-19
S Curve %	146	Ramp Rates	1-31

Parameter Name	Number	Group	Page
Save HIM Ref	192	HIM Ref Config	1-39
Save MOP Ref	194	MOP Config	1-39
Save To User Set	199	Drive Memory	1-40
ScaleX In Hi	477-495	Scaled Blocks	1-48
ScaleX In Lo	478-496	Scaled Blocks	1-49
ScaleX In Value	476-494	Scaled Blocks	1-48
ScaleX Out Hi	479-497	Scaled Blocks	1-49
ScaleX Out Lo	480-498	Scaled Blocks	1-49
ScaleX Out Value	481-499	Scaled Blocks	1-49
Shear Pin Time	189	Power Loss	1-38
Skip Freq Band	87	Spd Mode & Limits	1-23
Skip Frequency X	84-86	Spd Mode & Limits	1-23
Sleep Level	182	Restart Modes	1-37
Sleep Time	183	Restart Modes	1-37
Sleep-Wake Mode	178	Restart Modes	1-36
Sleep-Wake Ref	179	Restart Modes	1-37
Slip Comp Gain	122	Slip Comp	1-26
Slip RPM @ FLA	121	Slip Comp	1-26
Slip RPM Meter	123	Slip Comp	1-26
Speed Desired BW	449	Speed Regulator	1-30
SpdBand Integrat	603	Torq Proving	1-61
Spd Dev Band	602	Torq Proving	1-61
Speed Feedback	25	Metering	1-13
Speed Loop Meter	451	Speed Regulator	1-30
Speed Mode	80	Spd Mode & Limits	1-22
Speed Ref Source	213	Diagnostics	1-43
Speed Ref X Hi	91, 94	Speed Reference	1-24
Speed Ref X Lo	92, 95	Speed Reference	1-24
Speed Ref X Sel	90, 93	Speed Reference	1-24
Speed Reference	23	Metering	1-13
Speed Units	79	Spd Mode & Limits	1-21
Speed/Torque Mod	88	Spd Mode & Limits	1-23
Start At PowerUp	168	Restart Modes	1-34
Start Inhibits	214	Diagnostics	1-43
Start Mask	277	Masks & Owners	1-51
Start Owner	289	Masks & Owners	1-52
Start/Acc Boost	69	Volts per Hertz	1-19
Status X @ Fault	227, 228	Diagnostics	1-45
Stop Mode X	155, 156	Stop/Brake Modes	1-32
Stop Owner	288	Masks & Owners	1-52
Stop/BRK Mode X	155, 156	Stop/Brake Modes	1-32
SV Boost Filter	59	Torq Attributes	1-16
TB Man Ref Hi	97	Speed Reference	1-25
TB Man Ref Lo	98	Speed Reference	1-25
TB Man Ref Sel	96	Speed Reference	1-25
Testpoint X Data	235, 237	Diagnostics	1-46
Testpoint X Sel	234, 236	Diagnostics	1-46
TorqLim SlewRate	608	Torq Proving	1-61
TorqProve Cnfg	600	Torq Proving	1-60
TorqProve Setup	601	Torq Proving	1-60
Torq Ref A Div	430	Torq Attributes	1-18
Torque Current	4	Metering	1-12
Torque Perf Mode	53	Torq Attributes	1-15
Torque Ref B Mult	434	Torq Attributes	1-18
Torque Ref X Hi	428, 432	Torq Attributes	1-18
Torque Ref X Lo	429, 433	Torq Attributes	1-18
Torque Ref X Sel	427, 431	Torq Attributes	1-18
Torque Setpoint	435	Torq Attributes	1-19
Torque Setpoint2	438	Torq Attributes	1-19

Parameter Name	Number	Group	Page
Total Inertia	450	Speed Regulator	1-30
Trim % Setpoint	116	Speed Trim	1-26
Trim Hi	119	Speed Trim	1-26
Trim In Select	117	Speed Trim	1-26
Trim Lo	120	Speed Trim	1-26
Trim Out Select	118	Speed Trim	1-26
Voltage Class	202	Drive Memory	1-41
Wake Level	180	Restart Modes	1-37
Wake Time	181	Restart Modes	1-37
ZeroSpdFloatTime	605	Torq Proving	1-61

Parameter Cross Reference – by Number

Number	Parameter Name	Group	Page
1	Output Freq	Metering	1-12
2	Commanded Freq	Metering	1-12
	Commanded Speed	Metering	
3	Output Current	Metering	1-12
4	Torque Current	Metering	1-12
5	Flux Current	Metering	1-12
6	Output Voltage	Metering	1-12
7	Output Power	Metering	1-12
8	Output Powr Fctr	Metering	1-12
9	Elapsed MWh	Metering	1-12
10	Elapsed Run Time	Metering	1-12
11	MOP Frequency	Metering	1-13
	MOP Reference	Metering	
12	DC Bus Voltage	Metering	1-13
014	Elapsed kWh	Metering	1-13
13	DC Bus Memory	Metering	1-13
16	Analog In1 Value	Metering	1-13
17	Analog In2 Value	Metering	1-13
22	Ramped Speed	Metering	1-13
23	Speed Reference	Metering	1-13
24	Commanded Torque	Metering	1-13
25	Speed Feedback	Metering	1-13
26	Rated kW	Drive Data	1-14
27	Rated Volts	Drive Data	1-14
28	Rated Amps	Drive Data	1-14
29	Control SW Ver	Drive Data	1-14
40	Motor Type	Motor Data	1-14
41	Motor NP Volts	Motor Data	1-14
42	Motor NP FLA	Motor Data	1-14
43	Motor NP Hertz	Motor Data	1-14
44	Motor NP RPM	Motor Data	1-14
45	Motor NP Power	Motor Data	1-15
46	Mtr NP Pwr Units	Motor Data	1-15
47	Motor OL Hertz	Motor Data	1-15
48	Motor OL Factor	Motor Data	1-15
49	Motor Poles	Motor Data	1-15
53	Motor Cntl Sel	Torq Attributes	1-15
	Torque Perf Mode	Torq Attributes	
54	Maximum Voltage	Torq Attributes	1-15
55	Maximum Freq	Torq Attributes	1-16
56	Compensation	Torq Attributes	1-16
57	Flux Up Mode	Torq Attributes	1-16
58	Flux Up Time	Torq Attributes	1-16
59	SV Boost Filter	Torq Attributes	1-16
61	Autotune	Torq Attributes	1-17
62	IR Voltage Drop	Torq Attributes	1-17
63	Flux Current Ref	Torq Attributes	1-17
64	Ixo Voltage Drop	Torq Attributes	1-17
66	Autotune Torque	Torq Attributes	1-18
67	Inertia Autotune	Torq Attributes	1-18
69	Start/Acc Boost	Volts per Hertz	1-19
70	Run Boost	Volts per Hertz	1-19
71	Break Voltage	Volts per Hertz	1-20
72	Break Frequency	Volts per Hertz	1-20
79	Speed Units	Spd Mode & Limits	1-21

Number	Parameter Name	Group	Page
80	Feedback Select	Spd Mode & Limits	1-22
	Speed Mode	Spd Mode & Limits	
81	Minimum Speed	Spd Mode & Limits	1-22
82	Maximum Speed	Spd Mode & Limits	1-22
83	Overspeed Limit	Spd Mode & Limits	1-22
84-86	Skip Frequency X	Spd Mode & Limits	1-23
87	Skip Freq Band	Spd Mode & Limits	1-23
88	Speed/Torque Mod	Spd Mode & Limits	1-23
90, 93	Speed Ref X Sel	Speed Reference	1-24
91, 94	Speed Ref X Hi	Speed Reference	1-24
92, 95	Speed Ref X Lo	Speed Reference	1-24
96	TB Man Ref Sel	Speed Reference	1-25
97	TB Man Ref Hi	Speed Reference	1-25
98	TB Man Ref Lo	Speed Reference	1-25
99	Pulse Input Ref	Speed Reference	1-25
100	Jog Speed	Discrete Speeds	1-25
	Jog Speed 1	Discrete Speeds	
101-107	Preset Speed X	Discrete Speeds	1-25
108	Jog Speed 2	Discrete Speeds	1-25
116	Trim % Setpoint	Speed Trim	1-26
117	Trim In Select	Speed Trim	1-26
118	Trim Out Select	Speed Trim	1-26
119	Trim Hi	Speed Trim	1-26
120	Trim Lo	Speed Trim	1-26
121	Slip RPM @ FLA	Slip Comp	1-26
122	Slip Comp Gain	Slip Comp	1-26
123	Slip RPM Meter	Slip Comp	1-26
124	PI Configuration	Process PI	1-27
125	PI Control	Process PI	1-27
126	PI Reference Sel	Process PI	1-27
127	PI Setpoint	Process PI	1-27
128	PI Feedback Sel	Process PI	1-28
129	PI Integral Time	Process PI	1-28
130	PI Prop Gain	Process PI	1-28
131	PI Lower Limit	Process PI	1-28
132	PI Upper Limit	Process PI	1-28
133	PI Preload	Process PI	1-28
134	PI Status	Process PI	1-28
135	PI Ref Meter	Process PI	1-28
136	PI Fdbck Meter	Process PI	1-28
137	PI Error Meter	Process PI	1-29
138	PI Output Meter	Process PI	1-29
139	PI BW Filter	Process PI	1-29
140, 141	Accel Time X	Ramp Rates	1-31
142, 143	Decel Time X	Ramp Rates	1-31
145	DB While Stopped	Stop/Brake Modes	1-32
146	S Curve %	Ramp Rates	1-31
147	Current Lmt Sel	Load Limits	1-31
148	Current Lmt Val	Load Limits	1-31
149	Current Lmt Gain	Load Limits	1-31
150	Drive OL Mode	Load Limits	1-31
151	PWM Frequency	Load Limits	1-31
152	Droop RPM @ FLA	Load Limits	1-32
153	Regen Power Limit	Load Limits	1-32
154	Current Rate Limit	Load Limits	1-32

Number	Parameter Name	Group	Page
155, 156	Stop Mode X	Stop/Brake Modes	1-32
	Stop/BRK Mode X	Stop/Brake Modes	
157	DC Brk Lvl Sel	Stop/Brake Modes	1-32
158	DC Brake Level	Stop/Brake Modes	1-33
159	DC Brake Time	Stop/Brake Modes	1-33
160	Bus Reg Ki	Stop/Brake Modes	1-33
161, 162	Bus Reg Mode X	Stop/Brake Modes	1-33
163	DB Resistor Type	Stop/Brake Modes	1-34
164	Bus Reg Kp	Stop/Brake Modes	1-34
165	Bus Reg Kd	Stop/Brake Modes	1-34
166	Flux Braking	Stop/Brake Modes	1-34
167	Powerup Delay	Restart Modes	1-34
168	Start At PowerUp	Restart Modes	1-34
169	Flying Start En	Restart Modes	1-35
170	Flying StartGain	Restart Modes	1-35
174	Auto Rstrt Tries	Restart Modes	1-35
175	Auto Rstrt Delay	Restart Modes	1-35
177	Gnd Warn Level	Power Loss	1-37
178	Sleep-Wake Mode	Restart Modes	1-36
179	Sleep-Wake Ref	Restart Modes	1-37
180	Wake Level	Restart Modes	1-37
181	Wake Time	Restart Modes	1-37
182	Sleep Level	Restart Modes	1-37
183	Sleep Time	Restart Modes	1-37
184	Power Loss Mode	Power Loss	1-37
185	Power Loss Time	Power Loss	1-37
186	Power Loss Level	Power Loss	1-38
187	Load Loss Level	Power Loss	1-38
188	Load Loss Time	Power Loss	1-38
189	Shear Pin Time	Power Loss	1-38
190	Direction Mode	Direction Config	1-38
192	Save HIM Ref	HIM Ref Config	1-39
193	Man Ref Preload	HIM Ref Config	1-39
194	Save MOP Ref	MOP Config	1-39
195	MOP Rate	MOP Config	1-39
196	Param Access Lvl	Drive Memory	1-39
197	Reset To Defaults	Drive Memory	1-40
198	Load Frm Usr Set	Drive Memory	1-40
199	Save To User Set	Drive Memory	1-40
200	Reset Meters	Drive Memory	1-40
201	Language	Drive Memory	1-40
202	Voltage Class	Drive Memory	1-41
203	Drive Checksum	Drive Memory	1-41
209, 210	Drive Status X	Diagnostics	1-41
211, 212	Drive Alarm X	Diagnostics	1-42
213	Speed Ref Source	Diagnostics	1-43
214	Start Inhibits	Diagnostics	1-43
215	Last Stop Source	Diagnostics	1-43
216	Dig In Status	Diagnostics	1-44
217	Dig Out Status	Diagnostics	1-44
218	Drive Temp	Diagnostics	1-44
219	Drive OL Count	Diagnostics	1-44
220	Motor OL Count	Diagnostics	1-44
224	Fault Frequency	Diagnostics	1-44
	Fault Speed	Diagnostics	
225	Fault Amps	Diagnostics	1-44
226	Fault Bus Volts	Diagnostics	1-45
227, 228	Status X @ Fault	Diagnostics	1-45
229, 230	Alarm X @ Fault	Diagnostics	1-45

Number	Parameter Name	Group	Page
234, 236	Testpoint X Sel	Diagnostics	1-46
235, 237	Testpoint X Data	Diagnostics	1-46
238	Fault Config 1	Faults	1-46
240	Fault Clear	Faults	1-46
241	Fault Clear Mode	Faults	1-47
242	Power Up Marker	Faults	1-47
243	Fault 1 Code	Faults	1-47
244	Fault 1 Time	Faults	1-47
245	Fault 2 Code	Faults	1-47
246	Fault 2 Time	Faults	1-47
247	Fault 3 Code	Faults	1-47
248	Fault 3 Time	Faults	1-47
249	Fault 4 Code	Faults	1-47
250	Fault 4 Time	Faults	1-47
251	Fault 5 Code	Faults	1-47
252	Fault 5 Time	Faults	1-47
253	Fault 6 Code	Faults	1-47
254	Fault 6 Time	Faults	1-47
255	Fault 7 Code	Faults	1-47
256	Fault 7 Time	Faults	1-47
257	Fault 8 Code	Faults	1-47
258	Fault 8 Time	Faults	1-47
259	Alarm Config 1	Alarms	1-48
261	Alarm Clear	Alarms	1-48
262-269	Alarm X Code	Alarms	1-48
270	DPI Baud Rate	Comm Control	1-50
	DPI Data Rate	Comm Control	
271	Drive Logic Rslt	Comm Control	1-50
272	Drive Ref Rslt	Comm Control	1-50
273	Drive Ramp Rslt	Comm Control	1-50
274	DPI Port Sel	Comm Control	1-51
275	DPI Port Value	Comm Control	1-51
276	Logic Mask	Masks & Owners	1-51
277	Start Mask	Masks & Owners	1-51
278	Jog Mask	Masks & Owners	1-52
279	Direction Mask	Masks & Owners	1-52
280	Reference Mask	Masks & Owners	1-52
281	Accel Mask	Masks & Owners	1-52
282	Decel Mask	Masks & Owners	1-52
283	Fault Cir Mask	Masks & Owners	1-52
284	MOP Mask	Masks & Owners	1-52
285	Local Mask	Masks & Owners	1-52
288	Stop Owner	Masks & Owners	1-52
289	Start Owner	Masks & Owners	1-52
290	Jog Owner	Masks & Owners	1-52
291	Direction Owner	Masks & Owners	1-53
292	Reference Owner	Masks & Owners	1-53
293	Accel Owner	Masks & Owners	1-53
294	Decel Owner	Masks & Owners	1-53
295	Fault Cir Owner	Masks & Owners	1-53
296	MOP Owner	Masks & Owners	1-53
297	Local Owner	Masks & Owners	1-53
298	DPI Ref Select	Comm Control	1-51
299	DPI Fdbk Select	Comm Control	1-51
300-307	Data In XX	Datalinks	1-53
310-317	Data Out XX	Datalinks	1-54
320	Anlg In Config	Analog Inputs	1-54
321	Anlg In Sqr Root	Analog Inputs	1-54
322, 325	Analog In X Hi	Analog Inputs	1-55

Number	Parameter Name	Group	Page
323, 326	Analog In X Lo	Analog Inputs	1-55
324, 327	Analog In X Loss	Analog Inputs	1-55
340	Anlg Out Config	Analog Outputs	1-55
341	Anlg Out Absolut	Analog Outputs	1-55
342, 345	Analog OutX Sel	Analog Outputs	1-56
343, 346	Analog OutX Hi	Analog Outputs	1-56
344, 347	Analog OutX Lo	Analog Outputs	1-56
354, 355	Anlg OutX Scale	Analog Outputs	1-57
361-366	Digital InX Sel	Digital Inputs	1-58
377, 378	Anlg OutX Setpt	Analog Outputs	1-57
379	Dig Out Setpt	Digital Outputs	1-59
380, 384, 388	Digital OutX Sel	Digital Outputs	1-59
381, 385, 389	Dig OutX Level	Digital Outputs	1-59
382, 386, 390	Dig OutX OnTime	Digital Outputs	1-60
383, 387, 391	Dig OutX OffTime	Digital Outputs	1-60
412	Motor Fdbk Type	Speed Feedback	1-20
413	Encoder PPR	Speed Feedback	1-20
414	Enc Position Fdbk	Speed Feedback	1-20
415	Encoder Speed	Speed Feedback	1-20
416	Fdbk Filter Sel	Speed Feedback	1-20
419	Notch Filter Freq	Speed Feedback	1-20
420	Notch Filter K	Speed Feedback	1-21
421	Marker Pulse	Speed Feedback	1-21
422	Pulse In Scale	Speed Feedback	1-21
423	Encoder Z Chan	Speed Feedback	1-21
427, 431	Torque Ref X Sel	Torq Attributes	1-18
428, 432	Torque Ref X Hi	Torq Attributes	1-18
429, 433	Torque Ref X Lo	Torq Attributes	1-18
430	Torq Ref A Div	Torq Attributes	1-18
434	Torque Ref B Mult	Torq Attributes	1-18
435	Torque Setpoint	Torq Attributes	1-19
436	Pos Torque Limit	Torq Attributes	1-19
437	Neg Torque Limit	Torq Attributes	1-19
438	Torque Setpoint2	Torq Attributes	1-19
440	Control Status	Torq Attributes	1-19
441	Mtr Tor Cur Ref	Torq Attributes	1-19
445	Ki Speed Loop	Speed Regulator	1-30
446	Kp Speed Loop	Speed Regulator	1-30
447	Kf Speed Loop	Speed Regulator	1-30
449	Speed Desired BW	Speed Regulator	1-30
450	Total Inertia	Speed Regulator	1-30
451	Speed Loop Meter	Speed Regulator	1-30
454	Rev Speed Limit	Speed Regulator	1-23
459	PI Deriv Time	Process PI	1-29
460	PI Reference Hi	Process PI	1-29
461	PI Reference Lo	Process PI	1-29
462	PI Feedback Hi	Process PI	1-29
463	PI Feedback Lo	Process PI	1-29
476-494	ScaleX In Value	Scaled Blocks	1-48
477-495	ScaleX In Hi	Scaled Blocks	1-48
478-496	ScaleX In Lo	Scaled Blocks	1-49
479-497	ScaleX Out Hi	Scaled Blocks	1-49
480-498	ScaleX Out Lo	Scaled Blocks	1-49
481-499	ScaleX Out Value	Scaled Blocks	1-49
600	TorqProve Cnfg	Torq Proving	1-60
601	TorqProve Setup	Torq Proving	1-60

Number	Parameter Name	Group	Page
602	Spd Dev Band	Torq Proving	1-61
603	SpdBand Integrat	Torq Proving	1-61
604	Brk Release Time	Torq Proving	1-61
605	ZeroSpdFloatTime	Torq Proving	1-61
606	Float Tolerance	Torq Proving	1-61
607	Brk Set Time	Torq Proving	1-61
608	TorqLim SlewRate	Torq Proving	1-61
609	BrkSlip Count	Torq Proving	1-61
610	Brk Alarm Travel	Torq Proving	1-61
611	MicroPos Scale%	Torq Proving	1-61

Notes:

Troubleshooting

Chapter 4 provides information to guide you in troubleshooting the PowerFlex 700. Included is a listing and description of drive faults (with possible solutions, when applicable) and alarms.

For information on...	See page...
Faults and Alarms	2-1
Drive Status	2-2
Manually Clearing Faults	2-4
Fault Descriptions	2-4
Clearing Alarms	2-9
Alarm Descriptions	2-10
Common Symptoms and Corrective Actions	2-13
Testpoint Codes and Functions	2-16

Faults and Alarms

A fault is a condition that stops the drive. There are three fault types.

Type	Fault Description
①	Auto-Reset Run When this type of fault occurs, and [Auto Rstrt Tries] (see page 1-35) is set to a value greater than “0,” a user-configurable timer, [Auto Rstrt Delay] (see page 1-35) begins. When the timer reaches zero, the drive attempts to automatically reset the fault. If the condition that caused the fault is no longer present, the fault will be reset and the drive will be restarted.
②	Non-Resettable This type of fault normally requires drive or motor repair. The cause of the fault must be corrected before the fault can be cleared. The fault will be reset on power up after repair.
③	User Configurable These faults can be enabled/disabled to annunciate or ignore a fault condition.

An alarm is a condition that, if left untreated, may stop the drive. There are two alarm types.

Type	Alarm Description
①	User Configurable These alarms can be enabled or disabled through [Alarm Config 1] on page 1-48 .
②	Non-Configurable These alarms are always enabled.

Drive Status

The condition or state of your drive is constantly monitored. Any changes will be indicated through the LEDs and/or the HIM (if present).

Front Panel LED Indications

Figure 2.1 Typical Drive Status Indicators

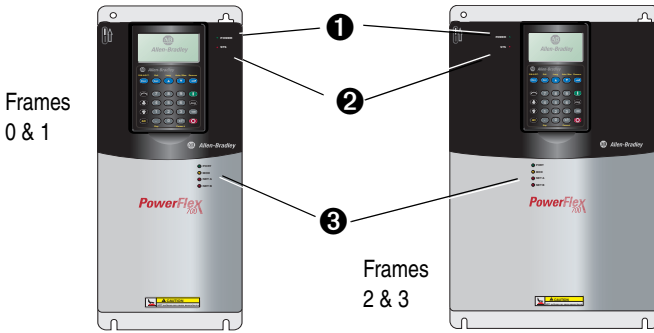

#	Name	Color	State	Description
1	PWR (Power)	Green	Steady	Illuminates when power is applied to the drive.
			Flashing	Drive ready, but not running & no faults are present.
2	STS (Status)	Green	Steady	Drive running, no faults are present.
			Flashing, Drive Stopped	A start inhibit condition exists, the drive cannot be started. Check parameter 214 [Start Inhibits].
		Yellow See page 2-10	Flashing, Drive Running	An intermittent type 1 alarm condition is occurring. Check parameter 211 [Drive Alarm 1].
			Steady, Drive Running	A continuous type 1 alarm condition exists. Check parameter 211 [Drive Alarm 1].
		Red See page 2-4	Flashing	Fault has occurred. Check [Fault x Code] or Fault Queue.
			Steady	A non-resettable fault has occurred.
3	PORT	Green	-	Status of DPI port internal communications (if present).
	MOD	Yellow	-	Status of communications module (when installed).
	NET A	Red	-	Status of network (if connected).
	NET B	Red	-	Status of secondary network (if connected).

Precharge Board LED Indications

Precharge Board LED indicators are found on Frame 5 & 6 drives.

Name	Color	State	Description
Power	Green	Steady	Indicates when precharge board power supply is operational
Alarm	Yellow	Flashing	Number in “[]” indicates flashes and associated alarm ⁽¹⁾ : [1] Low line voltage (<90%). [2] Very low line voltage (<50%). [3] Low phase (one phase <80% of line voltage). [4] Frequency out of range or asymmetry (line sync failed). [5] Low DC bus voltage (triggers ride-through operation). [6] Input frequency momentarily out of range (40-65 Hz). [7] DC bus short circuit detection active.
Fault	Red	Flashing	Number in “[]” indicates flashes and associated fault ⁽²⁾ : [2] DC bus short (Udc <2% after 20 ms). [4] Line sync failed or low line (Uac <50% Unom).

(1) An alarm condition automatically resets when the condition no longer exists



(2) A fault indicates a malfunction that must be corrected and can only be reset after cycling power.

HIM Indication

The LCD HIM also provides visual notification of a fault or alarm condition.

Condition	Display
<p>Drive is indicating a fault.</p> <p>The LCD HIM immediately reports the fault condition by displaying the following.</p> <ul style="list-style-type: none"> “Faulted” appears in the status line Fault number Fault name Time that has passed since fault occurred <p>Press Esc to regain HIM control.</p>	
<p>Drive is indicating an alarm.</p> <p>The LCD HIM immediately reports the alarm condition by displaying the following.</p> <ul style="list-style-type: none"> Alarm name (Type 2 alarms only) Alarm bell graphic 	

Manually Clearing Faults

Step	Key(s)
1. Press Esc to acknowledge the fault. The fault information will be removed so that you can use the HIM.	
2. Address the condition that caused the fault. The cause must be corrected before the fault can be cleared.	
3. After corrective action has been taken, clear the fault by one of these methods. <ul style="list-style-type: none"> • Press Stop • Cycle drive power • Set parameter 240 [Fault Clear] to "1." • "Clear Faults" on the HIM Diagnostic menu. 	

Fault Descriptions

Table 2.A Fault Types, Descriptions and Actions

Fault	No.	Type ⁽¹⁾	Description	Action
Analog In Loss	29	① ③	An analog input is configured to fault on signal loss. A signal loss has occurred. Configure with [Anlg In 1, 2 Loss] on page 1-55 .	1. Check parameters. 2. Check for broken/loose connections at inputs.
Anlg Cal Chksum	108		The checksum read from the analog calibration data does not match the checksum calculated.	Replace drive.
Auto Rstrt Tries	33	③	Drive unsuccessfully attempted to reset a fault and resume running for the programmed number of [Flt RstRun Tries]. Enable/Disable with [Fault Config 1] on page 1-46 .	Correct the cause of the fault and manually clear.
AutoTune Aborted	80		Autotune function was canceled by the user or a fault occurred.	Restart procedure.
Auxiliary Input	2	①	Auxiliary input interlock is open.	Check remote wiring.
Cntl Bd Overtemp Vector	55		The temperature sensor on the Main Control Board detected excessive heat.	1. Check Main Control Board fan. 2. Check surrounding air temperature. 3. Verify proper mounting/cooling.
DB Resistance	69		Resistance of the internal DB resistor is out of range.	Replace resistor.

Fault	No.	Type ⁽¹⁾	Description	Action
Decel Inhibit	24	③	The drive is not following a commanded deceleration because it is attempting to limit bus voltage.	<ol style="list-style-type: none"> 1. Verify input voltage is within drive specified limits. 2. Verify system ground impedance follows proper grounding techniques. 3. Disable bus regulation and/or add dynamic brake resistor and/or extend deceleration time. Refer to the Attention statement on page P-4
Drive OverLoad	64		Drive rating of 110% for 1 minute or 150% for 3 seconds has been exceeded.	Reduce load or extend Accel Time.
Drive Powerup	49		No fault displayed. Used as a Power Up Marker in the Fault Queue indicating that the drive power has been cycled.	
Excessive Load	79		Motor did not come up to speed in the allotted time during autotune.	<ol style="list-style-type: none"> 1. Uncouple load from motor. 2. Repeat Autotune.
Encoder Loss	91		Requires differential encoder. One of the 2 encoder channel signals is missing.	<ol style="list-style-type: none"> 1. Check Wiring. 2. Replace encoder.
Encoder Quad Err	90		Both encoder channels changed state within one clock cycle.	<ol style="list-style-type: none"> 1. Check for externally induced noise. 2. Replace encoder.
Faults Cleared	52		No fault displayed. Used as a marker in the Fault Queue indicating that the fault clear function was performed.	
Flt QueueCleared	51		No fault displayed. Used as a marker in the Fault Queue indicating that the clear queue function was performed.	
FluxAmpsRef Rang	78		The value for flux amps determined by the Autotune procedure exceeds the programmed [Motor NP FLA].	<ol style="list-style-type: none"> 1. Reprogram [Motor NP FLA] with the correct motor nameplate value. 2. Repeat Autotune.
Ground Fault	13	①	A current path to earth ground greater than 25% of drive rating.	Check the motor and external wiring to the drive output terminals for a grounded condition.
Hardware Fault	93		Hardware enable is disabled (jumpered high) but logic pin is still low.	<ol style="list-style-type: none"> 1. Check jumper. 2. Replace Main Control Board.
Hardware Fault	130		Gate array load error.	<ol style="list-style-type: none"> 1. Cycle power. 2. Replace Main Control Board.
Hardware Fault	131		Dual port failure.	<ol style="list-style-type: none"> 1. Cycle power. 2. Replace Main Control Board.
Heatsink OvrTemp	8	①	Heatsink temperature exceeds 100% of [Drive Temp].	<ol style="list-style-type: none"> 1. Verify that maximum ambient temperature has not been exceeded. 2. Check fan. 3. Check for excess load.

Fault	No.	Type ⁽¹⁾	Description	Action
HW OverCurrent	12	①	The drive output current has exceeded the hardware current limit.	Check programming. Check for excess load, improper DC boost setting, DC brake volts set too high or other causes of excess current.
Incompat MCB-PB	106	②	Drive rating information stored on the power board is incompatible with the main control board.	Load compatible version files into drive.
I/O Comm Loss	121		I/O Board lost communications with the Main Control Board.	Check connector. Check for induced noise. Replace I/O board or Main Control Board.
I/O Failure	122		I/O was detected, but failed the powerup sequence. I/O Board is separate in Standard & integral in Vector Control.	Replace I/O Board (Standard Control) or Main Control Board (Vector Control).
I/O Mismatch Standard	120		I/O board configuration not the same from last time drive was powered up.	Verify configuration.
Input Phase Loss	17		The DC bus ripple has exceeded a preset level.	Check incoming power for a missing phase/blown fuse.
IR Volts Range	77		“Calculate” is the autotune default and the value determined by the autotune procedure for IR Drop Volts is not in the range of acceptable values.	Re-enter motor nameplate data.
IXo VoltageRange	87		Voltage calculated for motor inductive impedance exceeds 25% of [Motor NP Volts].	<ol style="list-style-type: none"> 1. Check for proper motor sizing. 2. Check for correct programming of [Motor NP Volts], parameter 41. 3. Additional output impedance may be required.
Load Loss	15		Drive output torque current is below [Load Loss Level] for a time period greater than [Load Loss time].	<ol style="list-style-type: none"> 1. Verify connections between motor and load. 2. Verify level and time requirements.
Motor Overload	7	① ③	Internal electronic overload trip. Enable/Disable with [Fault Config 1] on page 1-46 .	An excessive motor load exists. Reduce load so drive output current does not exceed the current set by [Motor NP FLA].
Motor Thermistor	16		Thermistor output is out of range.	<ol style="list-style-type: none"> 1. Verify that thermistor is connected. 2. Motor is overheated. Reduce load.
NVS I/O Checksum	109		EEPROM checksum error.	<ol style="list-style-type: none"> 1. Cycle power and repeat function. 2. Replace Main Control Board.
NVS I/O Failure	110		EEPROM I/O error.	<ol style="list-style-type: none"> 1. Cycle power and repeat function. 2. Replace Main Control Board.

Fault	No.	Type ⁽¹⁾	Description	Action
Output Phase Loss	21		Current in one or more phases has been lost or remains below a preset level.	Check the drive and motor wiring. Check for phase-to-phase continuity at the motor terminals. Check for disconnected motor leads.
OverSpeed Limit	25	①	Functions such as Slip Compensation or Bus Regulation have attempted to add an output frequency adjustment greater than that programmed in [Overspeed Limit].	Remove excessive load or overhauling conditions or increase [Overspeed Limit].
OverVoltage	5	①	DC bus voltage exceeded maximum value.	Monitor the AC line for high line voltage or transient conditions. Bus overvoltage can also be caused by motor regeneration. Extend the decel time or install dynamic brake option.
Parameter Chksum	100	②	The checksum read from the board does not match the checksum calculated.	<ol style="list-style-type: none"> 1. Restore defaults. 2. Reload User Set if used.
Params Defaulted	48		The drive was commanded to write default values to EEPROM.	<ol style="list-style-type: none"> 1. Clear the fault or cycle power to the drive. 2. Program the drive parameters as needed.
Phase U to Grnd	38		A phase to ground fault has been detected between the drive and motor in this phase.	<ol style="list-style-type: none"> 1. Check the wiring between the drive and motor. 2. Check motor for grounded phase. 3. Replace drive.
Phase V to Grnd	39			
Phase W to Grnd	40			
Phase UV Short	41		Excessive current has been detected between these two output terminals.	<ol style="list-style-type: none"> 1. Check the motor and drive output terminal wiring for a shorted condition. 2. Replace drive.
Phase VW Short	42			
Phase UW Short	43			
Port 1-5 DPI Loss	81-85	②	DPI port stopped communicating. A SCANport device was connected to a drive operating DPI devices at 500k baud.	<ol style="list-style-type: none"> 1. If adapter was not intentionally disconnected, check wiring to the port. Replace wiring, port expander, adapters, Main Control Board or complete drive as required. 2. Check HIM connection. 3. If an adapter was intentionally disconnected and the [Logic Mask] bit for that adapter is set to "1", this fault will occur. To disable this fault, set the [Logic Mask] bit for the adapter to "0."
Port 1-5 Adapter	71-75		The communications card has a fault.	<ol style="list-style-type: none"> 1. Check DPI device event queue and corresponding fault information for the device.

Fault	No.	Type(1)	Description	Action
Power Loss	3	① ③	DC bus voltage remained below 85% of nominal for longer than [Power Loss Time]. Enable/Disable with [Fault Config 1] on page 1-46 .	Monitor the incoming AC line for low voltage or line power interruption.
Power Unit	70		One or more of the output transistors were operating in the active region instead of desaturation. This can be caused by excessive transistor current or insufficient base drive voltage.	<ol style="list-style-type: none"> 1. Check for damaged output transistors. 2. Replace drive.
Pulse In Loss	92		Z Channel is selected as a pulse input and no signal is present.	<ol style="list-style-type: none"> 1. Check wiring. 2. Replace pulse generator.
Pwr Brd Chksum1	104		The checksum read from the EEPROM does not match the checksum calculated from the EEPROM data.	Clear the fault or cycle power to the drive.
Pwr Brd Chksum2	105	②	The checksum read from the board does not match the checksum calculated.	<ol style="list-style-type: none"> 1. Cycle power to the drive. 2. If problem persists, replace drive.
Replaced MCB-PB	107	②	Main Control Board was replaced and parameters were not programmed.	<ol style="list-style-type: none"> 1. Restore defaults. 2. Reprogram parameters.
Shear Pin	63	③	Programmed [Current Lmt Val] has been exceeded. Enable/Disable with [Fault Config 1] on page 1-46 .	Check load requirements and [Current Lmt Val] setting.
Software Fault	88		Microprocessor handshake error.	Replace Main Control Board.
Software Fault	89		Microprocessor handshake error.	Replace Main Control Board.
SW OverCurrent	36	①	Drive output current has exceeded the 1ms current rating. This rating is greater than the 3 second current rating and less than the hardware overcurrent fault level. It is typically 200-250% of the drive continuous rating	Check for excess load, improper DC boost setting. DC brake volts set too high.
TorqPrv Spd Band	20		Difference between [Commanded Speed] and [Encoder Speed] has exceeded the level set in [Spd Dev Band] for a time period greater than [Spd Band Integrat].	<ol style="list-style-type: none"> 1. Check wiring between drive and motor. 2. Check release of mechanical brake.
Trnsistr OvrTemp	9	①	Output transistors have exceeded their maximum operating temperature.	<ol style="list-style-type: none"> 1. Verify that maximum ambient temperature has not been exceeded. 2. Check fan. 3. Check for excess load.

Fault	No.	Type ⁽¹⁾	Description	Action
UnderVoltage	4	① ③	DC bus voltage fell below the minimum value of 407V DC at 400/480V input or 204V DC at 200/240V input. Enable/Disable with [Fault Config 1] (page 1-46).	Monitor the incoming AC line for low voltage or power interruption.
UserSet1 Chksum	101	②	The checksum read from the user set does not match the checksum calculated.	Re-save user set.
UserSet2 Chksum	102	②		
UserSet3 Chksum	103	②		

(1) See [page 2-1](#) for a description of fault types.

Table 2.B Fault Cross Reference

No. ⁽¹⁾	Fault	No. ⁽¹⁾	Fault	No. ⁽¹⁾	Fault
2	Auxiliary Input	39	Phase V to Grnd	87	IXo VoltageRange
3	Power Loss	40	Phase W to Grnd	88	Software Fault
4	UnderVoltage	41	Phase UV Short	89	Software Fault
5	OverVoltage	42	Phase VW Short	90	Encoder Quad Err
7	Motor Overload	43	Phase UW Short	91	Encoder Loss
8	Heatsink OvrTemp	48	Params Defaulted	92	Pulse In Loss
9	Trnsistr OvrTemp	49	Drive Powerup	93	Hardware Fault
12	HW OverCurrent	51	Flt QueueCleared	100	Parameter Chksum
13	Ground Fault	52	Faults Cleared	101-103	UserSet Chksum
15	Load Loss	55	Cntl Bd Overtemp	104	Pwr Brd Chksum1
16	Motor Thermistor	63	Shear Pin	105	Pwr Brd Chksum2
17	Input Phase Loss	64	Drive OverLoad	106	Incompat MCB-PB
20	TorqPrv Spd Band	69	DB Resistance	107	Replaced MCB-PB
21	Output PhaseLoss	70	Power Unit	108	Anlg Cal Chksum
24	Decel Inhibit	71- 75	Port 1-5 Adapter	120	I/O Mismatch
25	OverSpeed Limit	77	IR Volts Range	121	I/O Comm Loss
29	Analog In Loss	78	FluxAmpsRef Rang	122	I/O Failure
33	Auto Rstrt Tries	79	Excessive Load	130	Hardware Fault
36	SW OverCurrent	80	AutoTune Aborted	131	Hardware Fault
38	Phase U to Grnd	81- 85	Port 1-5 DPI Loss		

(1) Fault numbers not listed are reserved for future use.

Clearing Alarms

Alarms are automatically cleared when the condition that caused the alarm is no longer present.

Alarm Descriptions

Table 2.C Alarm Descriptions and Actions

Alarm	No.	Type ⁽¹⁾	Description																																																																																																				
Analog In Loss	5	①	An analog input is configured for "Alarm" on signal loss and signal loss has occurred.																																																																																																				
Bipolar Conflict	20	②	Parameter 190 [Direction Mode] is set to "Bipolar" or "Reverse Dis" and one or more of the following digital input functions is configured: "Fwd/Reverse," "Run Forward," "Run Reverse," "Jog Forward" or "Jog Reverse."																																																																																																				
Brake Slipped	32	②	Encoder movement has exceeded the level in [BrkSlipCount] after the brake was set.																																																																																																				
Decel Inhibit	10	①	Drive is being inhibited from decelerating.																																																																																																				
Dig In ConflictA	17	②	<p>Digital input functions are in conflict. Combinations marked with a "⚡" will cause an alarm.</p> <p><i>* Jog 1 and Jog 2 with Vector Control Option</i></p> <table border="1" style="width: 100%; border-collapse: collapse; margin-top: 5px;"> <thead> <tr> <th></th> <th style="text-align: center;">Acc2/Dec2</th> <th style="text-align: center;">Accel 2</th> <th style="text-align: center;">Decel 2</th> <th style="text-align: center;">Jog *</th> <th style="text-align: center;">Jog Fwd</th> <th style="text-align: center;">Jog Rev</th> <th style="text-align: center;">Fwd/Rev</th> </tr> </thead> <tbody> <tr> <td style="text-align: left;">Acc2 / Dec2</td> <td></td> <td style="text-align: center;">⚡</td> <td style="text-align: center;">⚡</td> <td></td> <td></td> <td></td> <td></td> </tr> <tr> <td style="text-align: left;">Accel 2</td> <td style="text-align: center;">⚡</td> <td></td> <td></td> <td></td> <td></td> <td></td> <td></td> </tr> <tr> <td style="text-align: left;">Decel 2</td> <td style="text-align: center;">⚡</td> <td></td> <td></td> <td></td> <td></td> <td></td> <td></td> </tr> <tr> <td style="text-align: left;">Jog *</td> <td></td> <td></td> <td></td> <td></td> <td style="text-align: center;">⚡</td> <td style="text-align: center;">⚡</td> <td></td> </tr> <tr> <td style="text-align: left;">Jog Fwd</td> <td></td> <td></td> <td></td> <td style="text-align: center;">⚡</td> <td></td> <td></td> <td style="text-align: center;">⚡</td> </tr> <tr> <td style="text-align: left;">Jog Rev</td> <td></td> <td></td> <td></td> <td style="text-align: center;">⚡</td> <td></td> <td></td> <td style="text-align: center;">⚡</td> </tr> <tr> <td style="text-align: left;">Fwd/Rev</td> <td></td> <td></td> <td></td> <td></td> <td style="text-align: center;">⚡</td> <td style="text-align: center;">⚡</td> <td></td> </tr> </tbody> </table>		Acc2/Dec2	Accel 2	Decel 2	Jog *	Jog Fwd	Jog Rev	Fwd/Rev	Acc2 / Dec2		⚡	⚡					Accel 2	⚡							Decel 2	⚡							Jog *					⚡	⚡		Jog Fwd				⚡			⚡	Jog Rev				⚡			⚡	Fwd/Rev					⚡	⚡																																					
	Acc2/Dec2	Accel 2	Decel 2	Jog *	Jog Fwd	Jog Rev	Fwd/Rev																																																																																																
Acc2 / Dec2		⚡	⚡																																																																																																				
Accel 2	⚡																																																																																																						
Decel 2	⚡																																																																																																						
Jog *					⚡	⚡																																																																																																	
Jog Fwd				⚡			⚡																																																																																																
Jog Rev				⚡			⚡																																																																																																
Fwd/Rev					⚡	⚡																																																																																																	
Dig In ConflictB	18	②	<p>A digital Start input has been configured without a Stop input or other functions are in conflict. Combinations that conflict are marked with a "⚡" and will cause an alarm.</p> <p><i>* Jog 1 and Jog 2 with Vector Control Option</i></p> <table border="1" style="width: 100%; border-collapse: collapse; margin-top: 5px;"> <thead> <tr> <th></th> <th style="text-align: center;">Start</th> <th style="text-align: center;">Stop-CF</th> <th style="text-align: center;">Run</th> <th style="text-align: center;">Run Fwd</th> <th style="text-align: center;">Run Rev</th> <th style="text-align: center;">Jog *</th> <th style="text-align: center;">Jog Fwd</th> <th style="text-align: center;">Jog Rev</th> <th style="text-align: center;">Fwd/Rev</th> </tr> </thead> <tbody> <tr> <td style="text-align: left;">Start</td> <td></td> <td></td> <td style="text-align: center;">⚡</td> <td style="text-align: center;">⚡</td> <td style="text-align: center;">⚡</td> <td></td> <td style="text-align: center;">⚡</td> <td style="text-align: center;">⚡</td> <td></td> </tr> <tr> <td style="text-align: left;">Stop-CF</td> <td></td> <td></td> <td></td> <td></td> <td></td> <td></td> <td></td> <td></td> <td></td> </tr> <tr> <td style="text-align: left;">Run</td> <td style="text-align: center;">⚡</td> <td></td> <td></td> <td style="text-align: center;">⚡</td> <td style="text-align: center;">⚡</td> <td></td> <td style="text-align: center;">⚡</td> <td style="text-align: center;">⚡</td> <td></td> </tr> <tr> <td style="text-align: left;">Run Fwd</td> <td style="text-align: center;">⚡</td> <td></td> <td style="text-align: center;">⚡</td> <td></td> <td></td> <td style="text-align: center;">⚡</td> <td></td> <td></td> <td style="text-align: center;">⚡</td> </tr> <tr> <td style="text-align: left;">Run Rev</td> <td style="text-align: center;">⚡</td> <td></td> <td style="text-align: center;">⚡</td> <td></td> <td></td> <td style="text-align: center;">⚡</td> <td></td> <td></td> <td style="text-align: center;">⚡</td> </tr> <tr> <td style="text-align: left;">Jog *</td> <td></td> <td></td> <td></td> <td style="text-align: center;">⚡</td> <td style="text-align: center;">⚡</td> <td></td> <td></td> <td></td> <td></td> </tr> <tr> <td style="text-align: left;">Jog Fwd</td> <td style="text-align: center;">⚡</td> <td></td> <td style="text-align: center;">⚡</td> <td></td> <td></td> <td></td> <td></td> <td></td> <td></td> </tr> <tr> <td style="text-align: left;">Jog Rev</td> <td style="text-align: center;">⚡</td> <td></td> <td style="text-align: center;">⚡</td> <td></td> <td></td> <td></td> <td></td> <td></td> <td></td> </tr> <tr> <td style="text-align: left;">Fwd/Rev</td> <td></td> <td></td> <td></td> <td style="text-align: center;">⚡</td> <td style="text-align: center;">⚡</td> <td></td> <td></td> <td></td> <td></td> </tr> </tbody> </table>		Start	Stop-CF	Run	Run Fwd	Run Rev	Jog *	Jog Fwd	Jog Rev	Fwd/Rev	Start			⚡	⚡	⚡		⚡	⚡		Stop-CF										Run	⚡			⚡	⚡		⚡	⚡		Run Fwd	⚡		⚡			⚡			⚡	Run Rev	⚡		⚡			⚡			⚡	Jog *				⚡	⚡					Jog Fwd	⚡		⚡							Jog Rev	⚡		⚡							Fwd/Rev				⚡	⚡				
	Start	Stop-CF	Run	Run Fwd	Run Rev	Jog *	Jog Fwd	Jog Rev	Fwd/Rev																																																																																														
Start			⚡	⚡	⚡		⚡	⚡																																																																																															
Stop-CF																																																																																																							
Run	⚡			⚡	⚡		⚡	⚡																																																																																															
Run Fwd	⚡		⚡			⚡			⚡																																																																																														
Run Rev	⚡		⚡			⚡			⚡																																																																																														
Jog *				⚡	⚡																																																																																																		
Jog Fwd	⚡		⚡																																																																																																				
Jog Rev	⚡		⚡																																																																																																				
Fwd/Rev				⚡	⚡																																																																																																		
Dig In ConflictC	19	②	<p>More than one physical input has been configured to the same input function. Multiple configurations are not allowed for the following input functions.</p> <table style="width: 100%; margin-top: 5px;"> <tr> <td style="width: 33%;">Forward/Reverse</td> <td style="width: 33%;">Run Reverse</td> <td style="width: 33%;">Bus Regulation Mode B</td> </tr> <tr> <td>Speed Select 1</td> <td>Jog Forward</td> <td>Acc2 / Dec2</td> </tr> <tr> <td>Speed Select 2</td> <td>Jog Reverse</td> <td>Accel 2</td> </tr> <tr> <td>Speed Select 3</td> <td>Run</td> <td>Decel 2</td> </tr> <tr> <td>Run Forward</td> <td>Stop Mode B</td> <td></td> </tr> </table>	Forward/Reverse	Run Reverse	Bus Regulation Mode B	Speed Select 1	Jog Forward	Acc2 / Dec2	Speed Select 2	Jog Reverse	Accel 2	Speed Select 3	Run	Decel 2	Run Forward	Stop Mode B																																																																																						
Forward/Reverse	Run Reverse	Bus Regulation Mode B																																																																																																					
Speed Select 1	Jog Forward	Acc2 / Dec2																																																																																																					
Speed Select 2	Jog Reverse	Accel 2																																																																																																					
Speed Select 3	Run	Decel 2																																																																																																					
Run Forward	Stop Mode B																																																																																																						
Drive OL Level 1	8	①	The calculated IGBT temperature requires a reduction in PWM frequency. If [Drive OL Mode] is disabled and the load is not reduced, an overload fault will eventually occur.																																																																																																				

Alarm	No.	Type(t)	Description
Drive OL Level 2	9	①	The calculated IGBT temperature requires a reduction in Current Limit. If [Drive OL Mode] is disabled and the load is not reduced, an overload fault will eventually occur.
FluxAmpsRef Rang	26	②	The calculated or measured Flux Amps value is not within the expected range. Verify motor data and rerun motor tests.
Ground Warn	15	①	Ground current has exceeded the level set in [Gnd Warn Level].
In Phase Loss	13	①	The DC bus ripple has exceeded the level in [Phase Loss Level].
IntDBRes OvrHeat	6	①	The drive has temporarily disabled the DB regulator because the resistor temperature has exceeded a predetermined value.
IR Volts Range	25	②	The drive auto tuning default is "Calculate" and the value calculated for IR Drop Volts is not in the range of acceptable values. This alarm should clear when all motor nameplate data is properly entered.
Ixo Vlt Rang	28	②	Motor leakage inductance is out of range.
Load Loss	14		Output torque current is below [Load Loss Level] for a time period greater than [Load Loss time].
MaxFreq Conflict	23	②	The sum of [Maximum Speed] and [Overspeed Limit] exceeds [Maximum Freq]. Raise [Maximum Freq] or lower [Maximum Speed] and/or [Overspeed Limit] so that the sum is less than or equal to [Maximum Freq].
Motor Thermistor	12		The value at the thermistor terminals has been exceeded.
Motor Type Cflct	21	②	[Motor Type] has been set to "Synchr Reluc" or "Synchr PM" and one or more of the following exist: <ul style="list-style-type: none"> • [Torque Perf Mode] = "Sensrls Vect," "SV Economize" or "Fan/Pmp V/Hz." • [Flux Up Time] is greater than 0.0 Secs. • [Speed Mode] is set to "Slip Comp." • [Autotune] = "Static Tune" or "Rotate Tune."
NP Hz Conflict	22	②	Fan/pump mode is selected in [Torq Perf Mode] and the ratio of [Motor NP Hertz] to [Maximum Freq] is greater than 26.
Power Loss	3	①	Drive has sensed a power line loss.
Precharge Active	1	①	Drive is in the initial DC bus precharge state.
PTC Conflict	31	②	PTC is enabled for Analog In 1, which is configured as a 0-20 mA current source in [Anlg In Config].
Sleep Config	29	②	Sleep/Wake configuration error. With [Sleep-Wake Mode] = "Direct," possible causes include: drive is stopped and [Wake Level] < [Sleep Level], "Stop=CF," "Run," "Run Forward," or "Run Reverse." is not configured in [Digital Inx Sel].
Speed Ref Cflct	27	②	[Speed Ref x Sel] or [PI Reference Sel] is set to "Reserved".
Start At PowerUp	4	①	[Start At PowerUp] is enabled. Drive may start at any time within 10 seconds of drive powerup.

Alarm	No.	Type ⁽¹⁾	Description
TB Man Ref Cflct Vector	30	②	Occurs when: <ul style="list-style-type: none"> • “Auto/Manual” is selected (default) for [Digital In3 Sel], parameter 363 and • [TB Man Ref Sel], parameter 96 has been reprogrammed. No other use for the selected analog input may be programmed. Example: If [TB Man Ref Sel] is reprogrammed to “Analog In 2,” all of the factory default uses for “Analog In 2” must be reprogrammed (such as parameters 90, 117, 128 and 179). To correct: <ul style="list-style-type: none"> • Verify/reprogram the parameters that reference an analog input or • Reprogram [Digital In3] to another function or “Unused.”
TorqProve Cflct	49	②	When [TorqProve Cnfg] is enabled, [Motor Cntl Sel], [Feedback Select] and [Motor Fdbk Type] must be properly set (refer to page C-4).
UnderVoltage	2	①	The bus voltage has dropped below a predetermined value.
VHz Neg Slope	24	②	[Torq Perf Mode] = “Custom V/Hz” & the V/Hz slope is negative.
Waking	11	①	The Wake timer is counting toward a value that will start the drive.

(1) See [page 2-1](#) for a description of alarm types.

Table 2.D Alarm Cross Reference

No. ⁽¹⁾	Alarm	No. ⁽¹⁾	Alarm	No. ⁽¹⁾	Alarm
1	Precharge Active	13	In Phase Loss	25	IR Volts Range
2	UnderVoltage	14	Load Loss	26	FluxAmpsRef Rang
3	Power Loss	15	Ground Warn	27	Speed Ref Cflct
4	Start At PowerUp	17	Dig In ConflictA	28	Ixo Vlt Rang
5	Analog in Loss	18	Dig In ConflictB	29	Sleep Config
6	IntDBRes OvrHeat	19	Dig In ConflictC	30	TB Man Ref Cflct
8	Drive OL Level 1	20	Bipolar Conflict	31	PTC Conflict
9	Drive OL Level 2	21	Motor Type Cflct	32	Brake Slipped
10	Decel Inhibit	22	NP Hz Conflict	49	Torq Prove Cflct
11	Waking	23	MaxFreq Conflict		
12	Motor Thermistor	24	VHz Neg Slope		

(1) Alarm numbers not listed are reserved for future use.

Common Symptoms and Corrective Actions

Drive does not Start from Start or Run Inputs wired to the terminal block.

Cause(s)	Indication	Corrective Action
Drive is Faulted	Flashing red status light	Clear fault. <ul style="list-style-type: none"> Press Stop Cycle power Set [Fault Clear] to 1 (See page 1-46) “Clear Faults” on the HIM Diagnostic menu.
Incorrect input wiring. Refer to the Installation Instructions for wiring examples. <ul style="list-style-type: none"> 2 wire control requires Run, Run Forward, Run Reverse or Jog input. 3 wire control requires Start and Stop inputs. Jumper from terminal 25 to 26 is required. 	None	Wire inputs correctly and/or install jumper.
Incorrect digital input programming. <ul style="list-style-type: none"> Mutually exclusive choices have been made (i.e., Jog and Jog Forward). 2 wire and 3 wire programming may be conflicting. Exclusive functions (i.e., direction control) may have multiple inputs configured. Stop is factory default and is not wired. 	None	Program [Digital Inx Sel] for correct inputs. (See page 1-58) Start or Run programming may be missing.
	Flashing yellow status light and “DigIn CflctB” indication on LCD HIM. [Drive Status 2] shows type 2 alarm(s).	Program [Digital Inx Sel] to resolve conflicts. (See page 1-58) Remove multiple selections for the same function. Install stop button to apply a signal at stop terminal.

Drive does not Start from HIM.

Cause(s)	Indication	Corrective Action
Drive is programmed for 2 wire control. HIM Start button is disabled for 2 wire control.	None	If 2 wire control is required, no action needed. If 3 wire control is required, program [Digital Inx Sel] for correct inputs. (See page 1-58)

Drive does not respond to changes in speed command.

Cause(s)	Indication	Corrective Action
No value is coming from the source of the command.	LCD HIM Status Line indicates “At Speed” and output is 0 Hz.	<ol style="list-style-type: none"> 1. If the source is an analog input, check wiring and use a meter to check for presence of signal. 2. Check [Commanded Freq] for correct source. (See page 1-12)

Cause(s)	Indication	Corrective Action
Incorrect reference source has been programmed.	None	<ol style="list-style-type: none"> 3. Check [Speed Ref Source] for the source of the speed reference. (See page 1-43) 4. Reprogram [Speed Ref A Sel] for correct source. (See page 1-24)
Incorrect Reference source is being selected via remote device or digital inputs.	None	<ol style="list-style-type: none"> 5. Check [Drive Status 1], page 1-41, bits 12 and 13 for unexpected source selections. 6. Check [Dig In Status], page 1-44 to see if inputs are selecting an alternate source. 7. Reprogram digital inputs to correct "Speed Sel x" option. (See page 1-58)

Motor and/or drive will not accelerate to commanded speed.

Cause(s)	Indication	Corrective Action
Acceleration time is excessive.	None	Reprogram [Accel Time x]. (See page 1-31)
Excess load or short acceleration times force the drive into current limit, slowing or stopping acceleration.	None	<p>Check [Drive Status 2], bit 10 to see if the drive is in Current Limit. (See page 1-42)</p> <p>Remove excess load or reprogram [Accel Time x]. (See page 1-31)</p>
Speed command source or value is not as expected.	None	Check for the proper Speed Command using Steps 1 through 7 above.
Programming is preventing the drive output from exceeding limiting values.	None	Check [Maximum Speed] (See page 1-22) and [Maximum Freq] (See page 1-16) to assure that speed is not limited by programming.

Motor operation is unstable.

Cause(s)	Indication	Corrective Action
Motor data was incorrectly entered or Autotune was not performed.	None	<ol style="list-style-type: none"> 1. Correctly enter motor nameplate data. 2. Perform "Static" or "Rotate" Autotune procedure. (Param #061, page 1-17)

Drive will not reverse motor direction.

Cause(s)	Indication	Corrective Action
Digital input is not selected for reversing control.	None	Check [Digital Inx Sel], page 1-58 . Choose correct input and program for reversing mode.
Digital input is incorrectly wired.	None	Check input wiring.
Direction mode parameter is incorrectly programmed.	None	Reprogram [Direction Mode], page 1-38 for analog "Bipolar" or digital "Unipolar" control.
Motor wiring is improperly phased for reverse.	None	Switch two motor leads.
A bipolar analog speed command input is incorrectly wired or signal is absent.	None	<ol style="list-style-type: none"> 1. Use meter to check that an analog input voltage is present. 2. Check wiring. <p>Positive voltage commands forward direction. Negative voltage commands reverse direction.</p>

Stopping the drive results in a Decel Inhibit fault.

Cause(s)	Indication	Corrective Action
<p>The bus regulation feature is enabled and is halting deceleration due to excessive bus voltage. Excess bus voltage is normally due to excessive regenerated energy or unstable AC line input voltages. Internal timer has halted drive operation.</p>	<p>Decel Inhibit fault screen. LCD Status Line indicates "Faulted".</p>	<ol style="list-style-type: none"> 1. See Attention statement on page P-4. 2. Reprogram parameters 161/162 to eliminate any "Adjust Freq" selection. 3. Disable bus regulation (parameters 161 & 162) and add a dynamic brake. 4. Correct AC input line instability or add an isolation transformer. 5. Reset drive.

Testpoint Codes and Functions

Select testpoint with [Testpoint x Sel], parameters 234/236. Values can be viewed with [Testpoint x Data], parameters 235/237.

No. (1)	Description	Units	Values		
			Minimum	Maximum	Default
01	DPI Error Status	1	0	255	0
02	Heatsink Temp	0.1 degC	-100.0	100.0	0
03	Active Cur Limit	1	0	32767	0
04	Active PWM Freq	1 Hz	2	10	4
05	Life MegaWatt Hr ⁽²⁾	0.0001 MWh	0	214748.3647	0
06	Life Run Time	0.0001 Hrs	0	214748.3647	0
07	Life Pwr Up Time	0.0001 Hrs	0	214748.3647	0
08	Life Pwr Cycles	1	0	4294967295	0
09	Life MW-HR Fract ⁽²⁾	1	0	4294967295	0
10	MW-HR Frac Unit ⁽²⁾	1	0	4294967295	0
11	MCB Life Time	0.0001 Hrs	0	214748.3647	0
12	Raw Analog In 1	1	0		0
13	Raw Analog In 2	1	0		0
16	CS Msg Rx Cnt	1	0	65535	0
17	CS Msg Tx Cnt	1	0	65535	0
18	CS Timeout Cnt	1	0	255	0
19	CS Msg Bad Cnt	1	0	255	0
22	PC Msg Rx Cnt	1	0	65535	0
23	PC Msg Tx Cnt	1	0	65535	0
24-29	PC1-6 Timeout Cnt	1	0	255	0
30	CAN BusOff Cnt	1	0	65535	0
31	No. of Analog Inputs	1	0	x	0
32	Raw Temperature	1	0	65535	0
33	MTO Norm Mtr Amp	0.1 Amps	0	65535	0
34	DTO-Cmd Frequency	1	0	420	0
35	DTO-Cmd Cur Lim	0.1	0		0
36	DTO-Cmd DC Hold	1	0	32767	0
37	Control Bd Temp	0.1	0.0	60.0	0.0

(1) Enter in [Testpoint x Sel].

(2) Use the equation below to calculate total Lifetime MegaWatt Hours.

$$\left(\frac{\text{Value of Code 9}}{\text{Value of Code 10}} \times 0.1 \right) + \text{Value of Code 5} = \text{Total Lifetime MegaWatt Hours}$$

Supplemental Drive Information

For information on . .	See page . .
Drive Frame Sizes	A-1
Communication Configurations	A-1

Drive Frame Sizes

Similar PowerFlex 700 drive sizes are grouped into frame sizes to simplify spare parts ordering, dimensioning, etc. A cross reference of drive catalog numbers and their respective frame size is provided below.

Table A.A AC Input

Frame	208/240		400V		480V		600V		690V	
	ND Hp	HD Hp	ND kW	HD kW	ND Hp	HD Hp	ND Hp	HD Hp	ND kW	HD kW
0	0.5	0.33	0.37	0.25	0.5	0.33	1	0.5	–	–
	1	0.75	0.75	0.55	1	0.75	2	1	–	–
	–	–	1.5	0.75	2	1.5	3	2	–	–
	–	–	2.2	1.5	3	2	5	3	–	–
	–	–	4	2.2	5	3	7.5	5	–	–
	–	–	5.5	4	7.5	5	–	–	–	–
1	2	1.5	7.5	5.5	10	7.5	10	7.5	–	–
	3	2	11	7.5	15	10	15	10	–	–
	5	3	–	–	–	–	–	–	–	–
	7.5	5	–	–	–	–	–	–	–	–
2	10	7.5	15	11	20	15	20	15	–	–
	–	–	18.5	15	25	20	25	20	–	–
3	15	10	22	18.5	30	25	30	25	–	–
	20	15	30	22	40	30	40	30	–	–
	–	–	37	30	50	40	50	40	–	–
4	25	20	45	37	60	50	60	50	–	–
	30	25	–	–	–	–	–	–	–	–
5	40	30	55	45	75	60	75	60	45	37.5
	50	40	75	55	100	75	100	75	55	45
	–	–	–	–	–	–	–	–	75	55
	–	–	–	–	–	–	–	–	90	75
6	60	50	90	75	125	100	125	100	110	90
	75	60	110	90	150	125	150	125	132	110
	100	75	132	110	200	150	–	–	–	–

Table A.B DC Input

Frame	325V		540V		650V		810V		932V	
	ND Hp	HD Hp	ND kW	HD kW	ND Hp	HD Hp	ND Hp	HD Hp	ND kW	HD kW
0	0.5	0.33	–	–	0.5	0.33	1	0.75	–	–
	1	0.75	–	–	1	0.75	2	1.5	–	–
	–	–	–	–	2	1.5	3	2	–	–
	–	–	–	–	3	2	5	3	–	–
	–	–	–	–	5	3	7.5	5	–	–
	–	–	–	–	7.5	5	10	7.5	–	–
1	2	1.5	0.37	0.25	10	7.5	15	10	–	–
	3	2	0.75	0.55	15	10	–	–	–	–
	5	3	1.5	0.75	–	–	–	–	–	–
	7.5	5	2.2	1.5	–	–	–	–	–	–
	–	–	4	2.2	–	–	–	–	–	–
	–	–	5.5	4	–	–	–	–	–	–
	–	–	7.5	5.5	–	–	–	–	–	–
	–	–	11	7.5	–	–	–	–	–	–
2	10	7.5	15	11	20	15	20	15	–	–
	–	–	18.5	15	25	20	25	20	–	–
3	15	10	22	18.5	30	25	30	25	–	–
	20	15	30	22	40	30	40	30	–	–
	–	–	37	30	50	40	50	40	–	–
4	25	20	45	37	60	50	60	50	–	–
	30	25	–	–	–	–	–	–	–	–
5	40	30	55	45	75	60	100	75	45	37.5
	50	40	–	–	100	75	–	–	90	75
6	60	50	75	55	125	100	150	125	132	110
	75	60	90	75	150	125	–	–	–	–
	100	75	110	90	–	–	–	–	–	–
	–	–	132	110	200	150	–	–	–	–

Communication Configurations

Typical Programmable Controller Configurations

Important: If block transfers are programmed to continuously write information to the drive, care must be taken to properly format the block transfer. If attribute 10 is selected for the block transfer, values will be written only to RAM and will not be saved by the drive. This is the preferred attribute for continuous transfers. If attribute 9 is selected, each program scan will complete a write to the drives non-volatile memory (EEPROM). Since the EEPROM has a fixed number of allowed writes, continuous block transfers will quickly damage the EEPROM. Do Not assign attribute 9 to continuous block transfers. Refer to the individual communications adapter User Manual for details.

Logic Command/Status Words

Figure A.1 Logic Command Word

Logic Bits																Command	Description
15	14	13	12	11	10	9	8	7	6	5	4	3	2	1	0		
															x	Stop ⁽¹⁾	0 = Not Stop 1 = Stop
															x	Start ^{(1)/(2)}	0 = Not Start 1 = Start
														x		Jog	0 = Not Jog 1 = Jog
													x			Clear Faults	0 = Not Clear Faults 1 = Clear Faults
										x	x					Direction	00 = No Command 01 = Forward Command 10 = Reverse Command 11 = Hold Present Direction
									x							Local Control	0 = No Local Control 1 = Local Control
								x								MOP Increment	0 = Not Increment 1 = Increment
						x	x									Accel Rate	00 = No Command 01 = Use Accel Time 1 10 = Use Accel Time 2 11 = Use Present Time
				x	x											Decel Rate	00 = No Command 01 = Use Decel Time 1 10 = Use Decel Time 2 11 = Use Present Time
	x	x	x													Reference Select ⁽³⁾	000 = No Command 001 = Ref. 1 (Ref A Select) 010 = Ref. 2 (Ref B Select) 011 = Ref. 3 (Preset 3) 100 = Ref. 4 (Preset 4) 101 = Ref. 5 (Preset 5) 110 = Ref. 6 (Preset 6) 111 = Ref. 7 (Preset 7)
x																MOP Decrement	0 = Not Decrement 1 = Decrement

(1) A “0 = Not Stop” condition (logic 0) must first be present before a “1 = Start” condition will start the drive. The Start command acts as a momentary Start command. A “1” will start the drive, but returning to “0” will not stop the drive.

(2) This Start will not function if a digital input (parameters 361-366) is programmed for 2-Wire Control (option 7, 8 or 9).

(3) This Reference Select will not function if a digital input (parameters 361-366) is programmed for “Speed Sel 1, 2 or 3” (option 15, 16 or 17). Note that Reference Selection is “Exclusive Ownership” see [Reference Owner on page 1-53](#).

Figure A.2 Logic Status Word

Logic Bits																Status	Description	
15	14	13	12	11	10	9	8	7	6	5	4	3	2	1	0			
															x	Ready	0 = Not Ready 1 = Ready	
															x	Active	0 = Not Active 1 = Active	
															x	Command Direction	0 = Reverse 1 = Forward	
															x	Actual Direction	0 = Reverse 1 = Forward	
															x	Accel	0 = Not Accelerating 1 = Accelerating	
															x	Decel	0 = Not Decelerating 1 = Decelerating	
															x	Alarm	0 = No Alarm 1 = Alarm	
															x	Fault	0 = No Fault 1 = Fault	
															x	At Speed	0 = Not At Reference 1 = At Reference	
																	Local Control ⁽¹⁾	000 = Port 0 (TB) 001 = Port 1 010 = Port 2 011 = Port 3 100 = Port 4 101 = Port 5 110 = Reserved 111 = No Local
x	x	x	x														Reference Source	0000 = Ref A Auto 0001 = Ref B Auto 0010 = Preset 2 Auto 0011 = Preset 3 Auto 0100 = Preset 4 Auto 0101 = Preset 5 Auto 0110 = Preset 6 Auto 0111 = Preset 7 Auto 1000 = Term Blk Manual 1001 = DPI 1 Manual 1010 = DPI 2 Manual 1011 = DPI 3 Manual 1100 = DPI 4 Manual 1101 = DPI 5 Manual 1110 = Reserved 1111 = Jog Ref

(1) See "Owners" on [page 1-51](#) for further information.

HIM Overview

For information on . .	See page . .	For information on . .	See page . .
External and Internal Connections	B-1	Menu Structure	B-3
LCD Display Elements	B-2	Viewing and Editing Parameters	B-5
ALT Functions	B-2	Removing/Installing the HIM	B-8

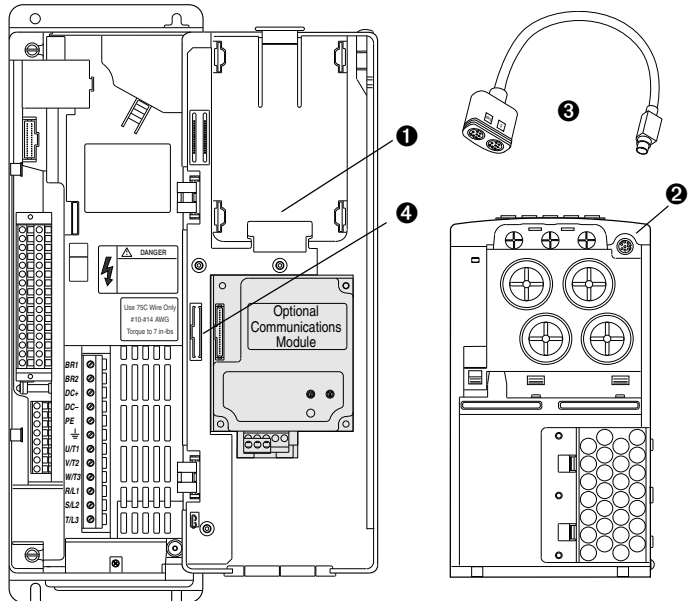

External and Internal Connections

The PowerFlex 700 provides a number of cable connection points (0 Frame shown).

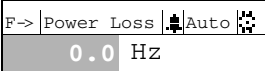

No.	Connector	Description
1	DPI Port 1	HIM connection when installed in cover.
2	DPI Port 2	Cable connection for handheld and remote options.
3	DPI Port 3 or 2	Splitter cable connected to DPI Port 2 provides additional port.
4	DPI Port 5	Cable connection for communications adapter.

LCD Display Elements

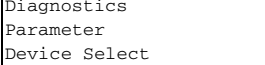







Display	Description
	Direction Drive Status Alarm Auto/Man Information
	Commanded or Output Frequency
	Programming / Monitoring / Troubleshooting

The top line of the HIM display can be configured with [DPI Fdbk Select], parameter 299 (Vector firmware 3.xxx and later).

ALT Functions

To use an ALT function, press the ALT key, release it, then press the programming key associated with one of the following functions:

Table B.A ALT Key Functions

ALT Key and then ...	Performs this function ...
 S.M.A.R.T.	Displays the S.M.A.R.T. screen.
 View	Allows the selection of how parameters will be viewed or detailed information about a parameter or component.
 Lang	Displays the language selection screen.
 Auto / Man	Switches between Auto and Manual Modes.
  Remove	Allows HIM removal without causing a fault if the HIM is not the last controlling device and does not have Manual control of the drive.
 Exp	Allows value to be entered as an exponent (Not available on PowerFlex 700).
 Param #	Allows entry of a parameter number for viewing/editing.

Menu Structure

Figure B.1 HIM Menu Structure

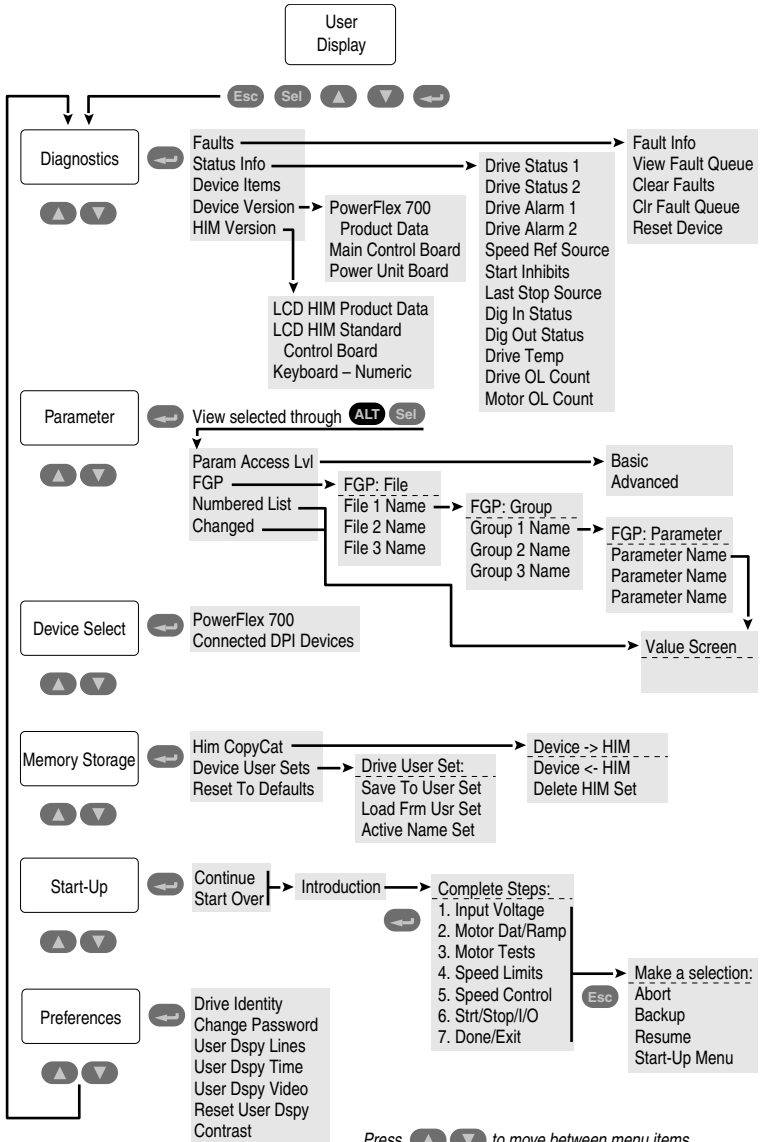

- Press **▲ ▼** to move between menu items
- Press **→** to select a menu item
- Press **Esc** to move 1 level back in the menu structure
- Press **ALT Sel** to select how to view parameters

Diagnostics Menu

When a fault trips the drive, use this menu to access detailed data about the drive.

Option	Description
Faults	View fault queue or fault information, clear faults or reset drive.
Status Info	View parameters that display status information about the drive.
Device Version	View the firmware version and hardware series of components.
HIM Version	View the firmware version and hardware series of the HIM.

Parameter Menu

Refer to [Viewing and Editing Parameters on page B-5](#).

Device Select Menu

Use this menu to access parameters in connected peripheral devices.

Memory Storage Menu

Drive data can be saved to, or recalled from, User and HIM sets.

User sets are files stored in permanent nonvolatile drive memory.

HIM sets are files stored in permanent nonvolatile HIM memory.

Option	Description
HIM Copycat Device -> HIM Device <- HIM	Save data to a HIM set, load data from a HIM set to active drive memory or delete a HIM set.
Device User Sets	Save data to a User set, load data from a User set to active drive memory or name a User set.
Reset To Defaults	Restore the drive to its factory-default settings.

Start Up Menu

See Installation Instructions.

Preferences Menu















The HIM and drive have features that you can customize.

Option	Description
Drive Identity	Add text to identify the drive.
Change Password	Enable/disable or modify the password.
User Dspy Lines	Select the display, parameter, scale and text for the User Display. The User Display is two lines of user-defined data that appears when the HIM is not being used for programming.
User Dspy Time	Set the wait time for the User Display or enable/disable it.
User Dspy Video	Select Reverse or Normal video for the Frequency and User Display lines.
Reset User Dspy	Return all the options for the User Display to factory default values.

The PowerFlex 700 drive is initially set to Basic Parameter View. To view all parameters, set parameter 196 [Param Access Lvl] to option 1 “Advanced”. Parameter 196 is not affected by the Reset to Defaults function.

Viewing and Editing Parameters

LCD HIM

Step	Key(s)	Example Displays				
1. In the Main Menu, press the Up Arrow or Down Arrow to scroll to “Parameter.”	 or 					
2. Press Enter. “FGP File” appears on the top line and the first three files appear below it.		<table border="1"> <tr><td>FGP: File</td></tr> <tr><td>Monitor</td></tr> <tr><td>Motor Control</td></tr> <tr><td>Speed Reference</td></tr> </table>	FGP: File	Monitor	Motor Control	Speed Reference
FGP: File						
Monitor						
Motor Control						
Speed Reference						
3. Press the Up Arrow or Down Arrow to scroll through the files.	 or 					
4. Press Enter to select a file. The groups in the file are displayed under it.		<table border="1"> <tr><td>FGP: Group</td></tr> <tr><td>Motor Data</td></tr> <tr><td>Torq Attributes</td></tr> <tr><td>Volts per Hertz</td></tr> </table>	FGP: Group	Motor Data	Torq Attributes	Volts per Hertz
FGP: Group						
Motor Data						
Torq Attributes						
Volts per Hertz						
5. Repeat steps 3 and 4 to select a group and then a parameter. The parameter value screen will appear.		<table border="1"> <tr><td>FGP: Parameter</td></tr> <tr><td>Maximum Voltage</td></tr> <tr><td>Maximum Freq</td></tr> <tr><td>Compensation</td></tr> </table>	FGP: Parameter	Maximum Voltage	Maximum Freq	Compensation
FGP: Parameter						
Maximum Voltage						
Maximum Freq						
Compensation						
6. Press Enter to edit the parameter.						
7. Press the Up Arrow or Down Arrow to change the value. If desired, press Sel to move from digit to digit, letter to letter, or bit to bit. The digit or bit that you can change will be highlighted.	 or  	<table border="1"> <tr><td>FGP: Par 55</td></tr> <tr><td>Maximum Freq</td></tr> <tr><td>60.00 Hz</td></tr> <tr><td>25 <> 400.00</td></tr> </table>	FGP: Par 55	Maximum Freq	60.00 Hz	25 <> 400.00
FGP: Par 55						
Maximum Freq						
60.00 Hz						
25 <> 400.00						
8. Press Enter to save the value. If you want to cancel a change, press Esc.						
9. Press the Up Arrow or Down Arrow to scroll through the parameters in the group, or press Esc to return to the group list.	 or  	<table border="1"> <tr><td>FGP: Par 55</td></tr> <tr><td>Maximum Freq</td></tr> <tr><td>90.00 Hz</td></tr> <tr><td>25 <> 400.00</td></tr> </table>	FGP: Par 55	Maximum Freq	90.00 Hz	25 <> 400.00
FGP: Par 55						
Maximum Freq						
90.00 Hz						
25 <> 400.00						

Numeric Keypad Shortcut

If using a HIM with a numeric keypad, press the ALT key and the +/- key to access the parameter by typing its number.

Linking Parameters (Vector Control Option Only)

Most parameter values are entered directly by the user. However, certain parameters can be “linked,” so the value of one parameter becomes the value of another. For Example: the value of an analog input can be linked to [Accel Time 2]. Rather than entering an acceleration time directly (via HIM), the link allows the value to change by varying the analog signal. This can provide additional flexibility for advanced applications.

Each link has 2 components:

- Source parameter – sender of information.
- Destination parameter – receiver of information.

Most parameters can be a source of data for a link, except parameter values that contain an integer representing an ENUM (text choice). These are not allowed, since the integer is not actual data (it represents a value). [Table B.B](#) lists the parameters that can be destinations. All links must be established between equal data types (parameter value formatted in floating point can only source data to a destination parameter value that is also floating point).

Establishing A Link







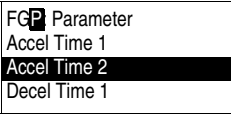

Step	Key(s)	Example Displays
1. Select a valid destination parameter (see Table B.B) to be linked (refer to page B-5). The parameter value screen will appear.		
2. Press Enter to edit the parameter. The cursor will move to the value line.		
3. Press ALT and then View (Sel). Next, press the Up or Down Arrow to change “Present Value” to “Define Link.” Press Enter.	 	
4. Enter the Source Parameter Number and press Enter.		
The linked parameter can now be viewed two different ways by repeating steps 1-4 and selecting “Present Value” or “Define Link.” If an attempt is made to edit the value of a linked parameter, “Parameter is Linked!” will be displayed, indicating that the value is coming from a source parameter and can not be edited.		 
5. To remove a link, repeat steps 1-5 and change the source parameter number to zero (0).		
6. Press Esc to return to the group list.		

Table B.B Linkable Parameters

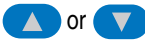
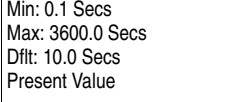
Number	Parameter	Number	Parameter	Number	Parameter
54	Maximum Voltage	159	DC Brake Time	462	PI Feedback Hi
56	Compensation	160	Bus Reg Ki	463	PI Feedback Lo
57	Flux Up Mode	164	Bus Reg Kp	476-494	ScaleX In Value
58	Flux Up Time	165	Bus Reg Kd	477-495	ScaleX In Hi
59	SV Boost Filter	170	Flying StartGain	478-496	ScaleX In Lo
62	IR Voltage Drop	175	Auto Rstrt Delay	479-497	ScaleX Out Hi
63	Flux Current Ref	180	Wake Level	480-498	ScaleX Out Lo
69	Start/Acc Boost	181	Wake Time	602	Spd Dev Band
70	Run Boost	182	Sleep Level	603	SpdBand Integrat
71	Break Voltage	183	Sleep Time	604	Brk Release Time
72	Break Frequency	185	Power Loss Time	605	ZeroSpdFloatTime
84	Skip Frequency 1	186	Power Loss Level	606	Float Tolerance
85	Skip Frequency 2	321	Anlg In Sqr Root	607	Brk Set Time
86	Skip Frequency 3	322	Analog In1 Hi	608	TorqLim SlewRate
87	Skip Freq Band	323	Analog In1 Lo	609	BrkSlip Count
91	Speed Ref A Hi	324	Analog In1 Loss	610	Brk Alarm Travel
92	Speed Ref A Lo	325	Analog In2 Hi	611	MicroPos Scale%
94	Speed Ref B Hi	326	Analog In2 Lo		
95	Speed Ref B Lo	327	Analog In2 Loss		
97	TB Man Ref Hi	343	Analog Out1 Hi		
98	TB Man Ref Lo	344	Analog Out1 Lo		
100	Jog Speed	346	Analog Out2 Hi		
101	Preset Speed 1	347	Analog Out2 Lo		
102	Preset Speed 2	381	Dig Out1 Level		
103	Preset Speed 3	382	Dig Out1 OnTime		
104	Preset Speed 4	383	Dig Out1 OffTime		
105	Preset Speed 5	385	Dig Out2 Level		
106	Preset Speed 6	386	Dig Out2 OnTime		
107	Preset Speed 7	387	Dig Out2 OffTime		
119	Trim Hi	389	Dig Out3 Level		
120	Trim Lo	390	Dig Out3 OnTime		
121	Slip RPM @ FLA	391	Dig Out3 OffTime		
122	Slip Comp Gain	416	Fdbk Filter Sel		
123	Slip RPM Meter	419	Notch Filter Freq		
127	PI Setpoint	420	Notch Filter K		
129	PI Integral Time	428	Torque Ref A Hi		
130	PI Prop Gain	429	Torque Ref A Lo		
131	PI Lower Limit	430	Torq Ref A Div		
132	PI Upper Limit	432	Torque Ref B Hi		
133	PI Preload	433	Torque Ref B Lo		
140	Accel Time 1	434	Torq Ref B Mult		
141	Accel Time 2	435	Torque Setpoint		
142	Decel Time 1	436	Pos Torque Limit		
143	Decel Time 2	437	Neg Torque Limit		
146	S-Curve %	445	Ki Speed Loop		
148	Current Lmt Val	446	Kp Speed Loop		
149	Current Lmt Gain	447	Kf Speed Loop		
151	PWM Frequency	449	Speed Desired BW		
152	Droop RPM @ FLA	450	Total Inertia		
153	Regen Power Limit	454	Rev Speed Limit		
154	Current Rate Limit	460	PI Reference Hi		
158	DC Brake Level	461	PI Reference Lo		

Removing/Installing the HIM

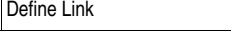
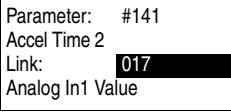
The HIM can be removed or installed while the drive is powered.

Important: HIM removal is only permissible in Auto mode. If the HIM is removed while in Manual mode or the HIM is the only remaining control device, a fault will occur.

Step	Key(s)	Example Displays
<p>To remove the HIM . . .</p> <ol style="list-style-type: none">1. Press ALT and then Enter (Remove). The Remove HIM confirmation screen appears.2. Press Enter to confirm that you want to remove the HIM.3. Remove the HIM from the drive. <p>To install HIM . . .</p> <ol style="list-style-type: none">1. Insert into drive or connect cable.	<p>ALT + </p>	<div data-bbox="631 406 854 518" style="border: 1px solid black; padding: 5px;"><p>Remove Op Intrfc: Press Enter to Disconnect Op Intrfc? (Port 1 Control)</p></div>

Application Notes

For information on . .	See page . .	For information on . .	See page . .
External Brake Resistor	C-1	Process PI for Standard Control	C-13
Lifting/Torque Proving	C-2	Reverse Speed Limit	C-16
Minimum Speed	C-7	Skip Frequency	C-17
Motor Control Technology	C-8	Sleep Wake Mode	C-19
Motor Overload	C-10	Start At PowerUp	C-21
Overspeed	C-11	Stop Mode	C-22
Power Loss Ride Through	C-12	Voltage Tolerance	C-24

External Brake Resistor

Figure C.1 External Brake Resistor Circuitry

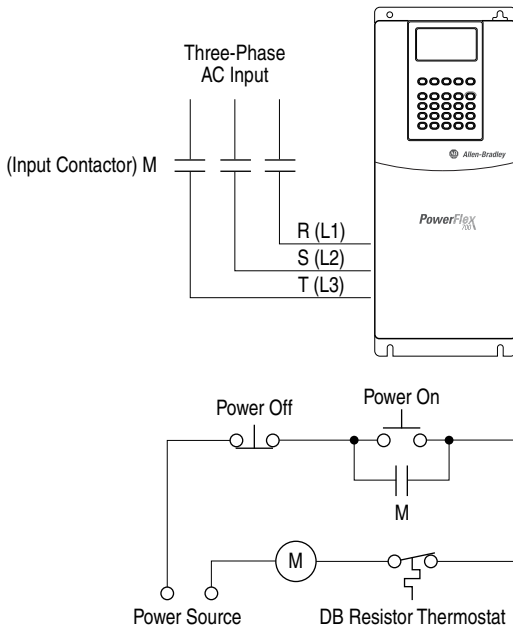

Lifting/Torque Proving

The lifting/torque proving feature of the PowerFlex 700 is intended for applications where proper coordination between motor control and a mechanical brake is required. Prior to releasing a mechanical brake, the drive will check motor output phase continuity and verify proper motor control (torque proving). The drive will also verify that the mechanical brake has control of the load prior to releasing drive control (brake proving). After the drive sets the brake, motor movement is monitored to ensure the brakes ability to hold the load.

Lifting Application functionality includes:

- Torque Proving (includes flux up and last torque measurement).
- Brake Proving (includes mode to slowly lower load if brake slips/fails).
- Float Capability
- Micro-Positioning
- Fast Stop
- Speed Deviation Fault, Output Phase Loss Fault, Encoder Loss Fault.

The Lifting/Torque Proving feature is only available in Vector firmware versions 3.xxx and later. It is intended to operate in the FVC Vector Control mode (see [Motor Cntl Sel], parameter 053) with an encoder. Motor movement is monitored through the encoder feedback which excludes the other feedback modes from being used.



ATTENTION: Loss of control in suspended load applications can cause personal injury and/or equipment damage. Loads must always be controlled by the drive or a mechanical brake. Parameters 600-611 are designed for lifting/torque proving applications. It is the responsibility of the engineer and/or end user to configure drive parameters, test any lifting functionality and meet safety requirements in accordance with all applicable codes and standards.

Lifting/Torque Proving Manual Start Up

It is possible to use the Assisted Start Up to tune the motor. However, it is recommended that the motor be disconnected from the hoist/crane equipment during the routine. If this is not possible, refer to steps [1](#) through [12](#) on the following pages.



ATTENTION: To guard against personal injury and/or equipment damage caused by unexpected brake release, verify Digital Out 1 brake connections and/or programming. The default drive configuration energizes the Digital Out 1 relay when power is applied to the drive. If the brake is connected to this relay, it could be released. If necessary, disconnect the relay output until wiring/programming can be verified.

Initial Static Auto Tune Test

1. Set the following parameters as shown.

No.	Name	Value	Notes
380	[Digital Out1 Sel]	"9, At Speed"	keeps brake engaged during test
041-045	[Motor NP . . .]	per nameplate	enter motor nameplate data
053	[Motor Cntl Sel]	"4, FVC Vector"	
080	[Feedback Select]	"3, Encoder"	
061	[Autotune]	"1, Static Tune"	

2. Press the Start key on the HIM. Parameters 062-064 will be updated.

Motor Rotation/Encoder Direction Test

3. Set the following parameters as shown.

No.	Name	Value	Notes
053	[Motor Cntl Sel]	"0, Sensrls Vect"	
080	[Feedback Select]	"0, Open Loop"	
090	[Digital Out1 Sel]	"11, Preset Spd1"	
238	[Fault Config 1]	Bit 8, "In PhaseLoss" = 1 Bit 12, "OutPhaseLoss" = 1	
380	[Digital Out1 Sel]	"4, Run"	releases brake

Important: If the direction of travel is critical at this point, perform short jogs to determine which run direction (RUNFWD or RUNREV) should be used in the next steps.

4. Press Start and run the drive in the desired direction. Observe the direction of motor rotation.

If rotation is not in the desired direction:

- remove drive power and reverse the two motor leads, or . . .
- set bit 5 of [Compensation], parameter 56 to "Mtr Lead Rev."

5. With the drive running, observe [Encoder Speed], parameter 415. If the sign of the encoder is not the same as the displayed frequency, remove drive power and reverse encoder leads A and A NOT.
6. With the drive running, verify correct motor rotation and encoder direction. Set [Motor Fdbk Type], parameter 412 to "1, Quad Check." Stop the drive.

Rotate AutoTune Test



ATTENTION: In this test the following conditions will occur:

- The motor will be run for 12 seconds at base frequency (60 Hz). Note that equipment travel during this 12 second interval may exceed equipment limits. However, travel distance can be reduced by setting [Maximum Speed], parameter 82 to a value less than 45 Hz (i.e. 22.5 Hz = 12 seconds at 30 Hz).
- The brake will be released without torque provided by the drive for 15 seconds.

To guard against personal injury and/or equipment damage, this test should not be performed if either of the above conditions are considered unacceptable by the user.

7. Set the following parameters as shown.

No.	Name	Value	Notes
053	[Motor Cntl Sel]	"4, FVC Vector"	
080	[Feedback Select]	"3, Encoder"	
061	[Autotune]	"2, Rotate Tune"	

8. Start the drive and run the motor in the desired direction. Parameters 062, 063, 064 & 121 will be updated.

Inertia AutoTune Test

9. Set [Inertia Autotune], parameter 067 to "1, Inertia Tune."
10. Press Start and run the motor in the direction desired. Parameters 445, 446 and 450 will be updated.
11. Set [Speed Desired BW], parameter 449 to desired setting.
12. Set up is complete - check for proper operation.

Drive Setup

[TorqProve Cnfg], parameter 600 must be set to "Enabled." Once this is set, a Type 2 alarm will be active until the following three parameter settings are entered:

No.	Name	Value	Notes
053	[Motor Cntl Sel]	"4, FVC Vector"	
080	[Feedback Select]	"3, Encoder"	
412	[Motor Fdbk Type]	"1, Quad Check"	

Installation/Wiring

When [TorqProve Cnfg] is set to “Enable,” the Digital Out 1 relay is used to control the external brake contactor. The normally open (N.O.) contact, when closed, is intended to energize the contactor. This provides the mechanical brake with voltage, causing the brake to release. Any interruption of power to the contactor will set the mechanical brake. Programming [Digital Out1 Sel], parameter 380 will be ignored when [TorqProve Cnfg] is set to “Enable.”

Figure C.2 Typical Torque Proving Configuration

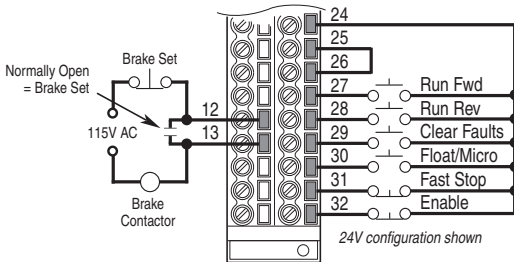

Lifting/Torque Proving Application Programming

The PowerFlex 700 lifting application is mainly influenced by parameters 600 through 611 in the Torque Proving group of the Application file. [Figure C.3](#) and the paragraphs that follow describe programming.

Figure C.3 Torque Proving Flow Diagram

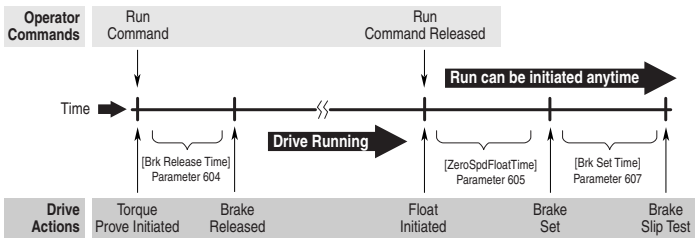

All times between Drive Actions are programmable and can be made very small (i.e. Brake Release Time can be 0.1 seconds)

Torque Proving

When the drive receives a start command to begin a lifting operation, the following actions occur:

1. The drive first performs a transistor diagnostic test to check for phase-to-phase and phase-to-ground shorts. A failure status from either of these tests will result in a drive fault and the brake relay will NOT be energized (brake remains set).
2. The drive will then provide the motor with flux as well as perform a check for current flow through all three motor phases. This ensures that torque will be delivered to the load when the mechanical brake is released. When torque proving is enabled, open phase loss detection is performed regardless of the setting of Bit 12 of [Fault Config 1], parameter 238.
3. If the drive passes all tests, the brake will be released and the drive will take control of the load after the programmed time in [Brk Release Time], parameter 604 which is the typical mechanical release time of the brake.

Brake Proving

When the drive receives a stop command to end a lifting operation, the following actions occur:

1. The brake is commanded closed when the speed of the motor reaches zero.
2. After the time period programmed in [Brk Set Time], parameter 607, the drive will verify if the brake is capable of holding torque. It will do this by ramping the torque down at a rate set in [TorqLim SlewRate], parameter 608. Note that the drive can be started again at any time without waiting for either of the above timers to finish.
3. While the torque is ramping down, the drive will perform a brake slip test. If movement exceeds the limit set in [BrkSlip Count], parameter 609, then an alarm is set and the drive will start a brake slip procedure. The drive will allow the motor to travel the distance programmed [Brk Alarm Travel], parameter 610. Another slip test will be performed and will repeat continuously until; A) the load stops slipping, or B) the load reaches the ground. This feature keeps control of the load and returns it to the ground in a controlled manner in the event of a mechanical brake failure.

Speed Monitoring / Speed Band Limit

This routine is intended to fault the drive if the difference between the speed reference and the encoder feedback is larger than the value set in [Spd Dev Band], parameter 602 and the drive is NOT making any progress toward the reference. [SpdBand Integrat], parameter 603 sets the time that the speed difference can be greater than the deviation band before causing a fault and setting the brake.

Float

Float is defined as the condition when the drive is holding the load at zero hertz while holding off the mechanical brake. The float condition starts when the frequency drops below the speed set in [Float Tolerance], parameter 606. Float will stay active for a period of time set by [ZeroSpdFloatTime], parameter 605. If a digital input (parameters 361-366) is set to “Micro Pos” (also Float) and it is closed, the Float condition will stay active and will disregard the timer. This signal is also available through a communication device, see [TorqProve Setup], parameter 601.

Micro Position

Micro Position refers to rescaling of the commanded frequency by a percentage entered in [MicroPos Scale %], parameter 611. This allows for slower operation of a lift which provides an operator with better resolution when positioning a load. Micro Position is activated only when the drive is running at or near zero speed. This can be initiated by a digital input configured as Micro Pos or through a communication device ([TorqProve Setup]) which is the same digital input which signals the float condition.

Fast Stop

Fast Stop is intended to stop the load as fast as possible then set the mechanical brake. The Fast Stop can be initiated from a digital input or through a communication device through [TorqProve Setup]. The difference from a normal stop is that the decel time is forced to be 0.1 seconds. When the Torque Proving function is enabled, the Float time is ignored at the end of the ramp. This feature can be used without enabling the Torque Proving function.

Minimum Speed

Refer to [Reverse Speed Limit on page C-16](#)

Motor Control Technology

Within the PowerFlex family there are several motor control technologies:

- Torque Producers
- Torque Controllers
- Speed Regulators

Torque Producers

Volts/Hertz

This technology follows a specific pattern of voltage and frequency output to the motor, regardless of the motor being used. The shape of the V/Hz curve can be controlled a limited amount, but once the shape is determined, the drive output is fixed to those values. Given the fixed values, each motor will react based on its own speed/torque characteristics.

This technology is good for basic centrifugal fan/pump operation and for most multi-motor applications. Torque production is generally good.

Sensorless Vector

This technology combines the basic Volts/Hertz concept with known motor parameters such as Rated FLA, HP, Voltage, stator resistance and flux producing current. Knowledge of the individual motor attached to the drive allows the drive to adjust the output pattern to the motor and load conditions. By identifying motor parameters, the drive can maximize the torque produced in the motor and extend the speed range at which that torque can be produced.

This technology is excellent for applications that require a wider speed range and applications that need maximum possible torque for breakaway, acceleration or overload. Centrifuges, extruders, conveyors and others are candidates.

Torque Controllers

Vector

This technology differs from the two above, because it actually controls or regulates torque. Rather than allowing the motor and load to actually determine the amount of torque produced, Vector technology allows the drive to regulate the torque to a defined value. By independently identifying and controlling both flux and torque currents in the motor, true control of torque is achieved. High bandwidth current regulators remain active with or without encoder feedback to produce outstanding results.

This technology is excellent for those applications where torque control, rather than mere torque production, is key to the success of the process. These include web handling, demanding extruders and lifting applications such as hoists or material handling.

Vector Control can operate in one of two configurations:

1. Encoderless

Not to be confused with Sensorless Vector above, Encoderless Vector based on Allen-Bradley's patented Field Oriented Control technology means that a feedback device is not required. Torque control can be achieved across a significant speed range without feedback.

2. Closed Loop (with Encoder)



Vector Control with encoder feedback utilizes Allen-Bradley's Force Technology™. This industry leading technology allows the drive to control torque over the entire speed range, including zero speed. For those applications that require smooth torque regulation at very low speeds or full torque at zero speed, Closed Loop Vector Control is the answer.

Speed Regulators

Any of the PowerFlex drives, regardless of their motor control technology (Volts/Hz, Sensorless Vector or Vector) can be set up to regulate speed. Speed regulation and torque regulation must be separated to understand drive operation.

The PowerFlex 70 and PowerFlex 700 with Standard Control can be programmed to regulate speed using the slip compensation feature. Slip compensation reacts to load changes by adjusting the drive output frequency to maintain motor speed. Torque production operates independently. This feature produces speed regulation of about 0.5% of base speed over a specified speed range (40:1 for V/Hz and 80:1 for Sensorless Vector). These two drives do not have the capability to extend the speed range or tighten the speed regulation below 0.5% because they do not have connections for a feedback device.

The PowerFlex 700 with the Vector Control option can offer better speed regulation by adding speed feedback. Using a speed feedback device (encoder) tightens speed regulation to 0.001% of base speed and extends the speed range to zero speed.

Motor Overload

For single motor applications the drive can be programmed to protect the motor from overload conditions. An electronic thermal overload I²T function emulates a thermal overload relay. This operation is based on three parameters; [Motor NP FLA], [Motor OL Factor] and [Motor OL Hertz] (parameters 042, 048 and 047, respectively).

[Motor NP FLA] is multiplied by [Motor OL Factor] to allow the user to define the continuous level of current allowed by the motor thermal overload. [Motor OL Hertz] is used to allow the user to adjust the frequency below which the motor overload is derated.

The motor can operate up to 102% of FLA continuously. If the drive had just been activated, it will run at 150% of FLA for 180 seconds. If the motor had been operating at 100% for over 30 minutes, the drive will run at 150% of FLA for 60 seconds. These values assume the drive is operating above [Motor OL Hertz], and that [Motor OL Factor] is set to 1.00.

Operation below 100% current causes the temperature calculation to account for motor cooling.

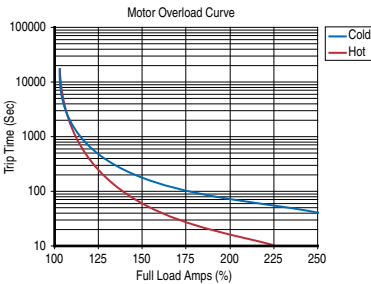

[Motor OL Hertz] defines the frequency where motor overload capacity derate should begin. The motor overload capacity is reduced when operating below [Motor OL Hertz]. For all settings of [Motor OL Hertz] other than zero, the overload capacity is reduced to 70% at an output frequency of zero.

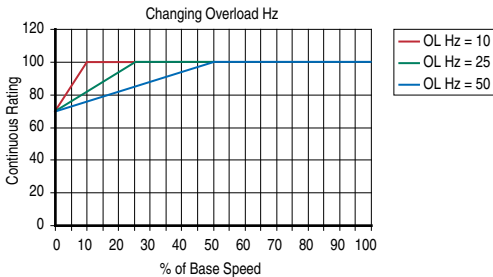

[Motor NP FLA] is multiplied by [Motor OL Factor] to select the rated current for the motor thermal overload. This can be used to raise or lower the level of current that will cause the motor thermal overload to trip. The effective overload factor is a combination of [Motor OL Hertz] and [Motor OL Factor].

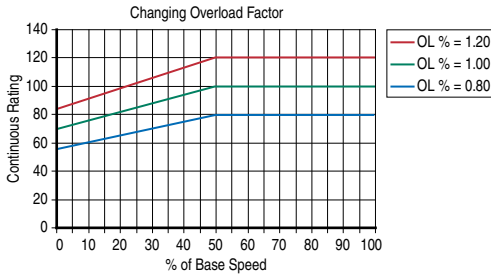

Overspeed

Overspeed Limit is a user programmable value that allows operation at maximum speed, but also provides an “overspeed band” that will allow a speed regulator such as encoder feedback or slip compensation to increase the output frequency above maximum speed in order to maintain maximum motor speed.

The figure below illustrates a typical Custom V/Hz profile. Minimum Speed is entered in Hertz and determines the lower speed reference limit during normal operation. Maximum Speed is entered in Hertz and determines the upper speed reference limit. The two “Speed” parameters only limit the speed reference and not the output frequency.

The actual output frequency at maximum speed reference is the sum of the speed reference plus “speed adder” components from functions such as slip compensation.

The Overspeed Limit is entered in Hertz and added to Maximum Speed and the sum of the two (Speed Limit) limit the output frequency. This sum (Speed Limit) must be compared to Maximum Frequency and an alarm is initiated which prevents operation if the Speed Limit exceeds Maximum Frequency.

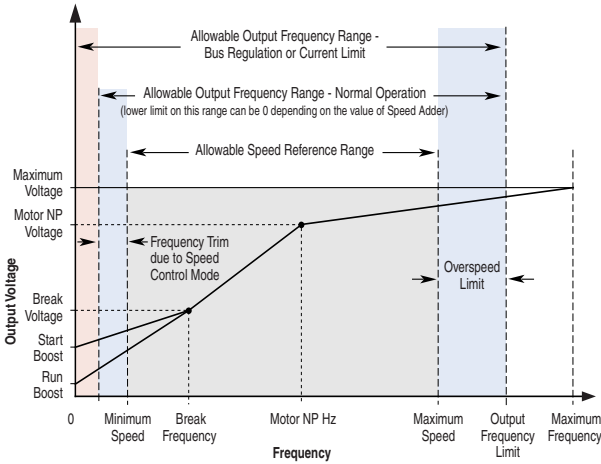

Power Loss Ride Through

When AC input power is lost, energy is being supplied to the motor from the DC bus capacitors. The energy from the capacitors is not being replaced (via the AC line), thus, the DC bus voltage will fall rapidly. The drive must detect this fall and react according to the way it is programmed. Two parameters display DC bus voltage:

- [DC Bus Voltage] - displays the instantaneous value
- [DC Bus Memory] - displays a 6 minute running average of the voltage.

All drive reactions to power loss are based on [DC Bus Memory]. This averages low and high line conditions and sets the drive to react to the average rather than assumed values. For example, a 480V installation would have a 480V AC line and produce a nominal 648V DC bus. If the drive were to react to a fixed voltage for line loss detect, (i.e. 533V DC), then normal operation would occur for nominal line installations. However, if a lower nominal line voltage of 440V AC was used, then nominal DC bus voltage would be only 594V DC. If the drive were to react to the fixed 533V level (only -10%) for line loss detect, any anomaly might trigger a false line loss detection. Line loss, therefore always uses the 6 minute average for DC bus voltage and detects line loss based on a fixed percentage of that memory. In the same example, the average would be 594V DC instead of 650V DC and the fixed percentage, 27% for “Coast to Stop” and 18% for all others, would allow identical operation regardless of line voltage.

The PowerFlex 70 uses only these fixed percentages. The PowerFlex 700 can selectively use the same percentages or the user can set a trigger point for line loss detect. The adjustable trigger level is set using [Power Loss Level] (see [\[Power Loss Level\] on page 1-38](#)).

Figure C.4 Power Loss Mode = Coast

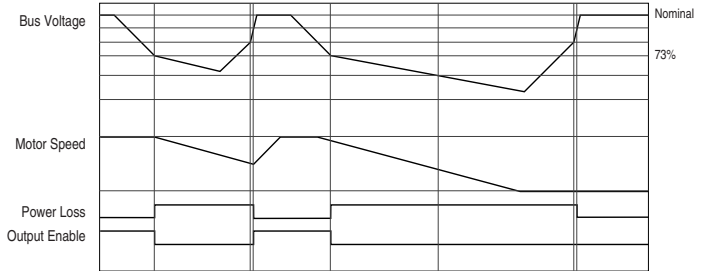
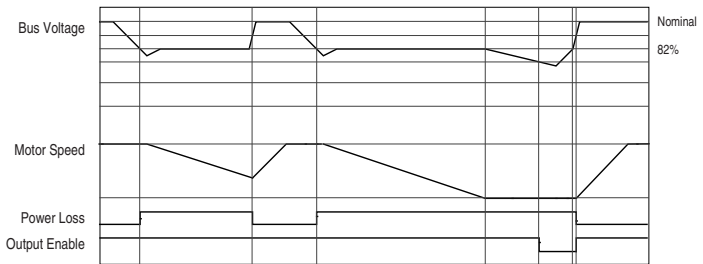

Figure C.5 Power Loss Mode = Decel



Process PI for Standard Control

The internal PI function of the PowerFlex 700 provides closed loop process control with proportional and integral control action. The function is designed for use in applications that require simple control of a process without external control devices. The PI function allows the microprocessor of the drive to follow a single process control loop.

The PI function reads a process variable input to the drive and compares it to a desired setpoint stored in the drive. The algorithm will then adjust the output of the PI regulator, changing drive output frequency to try and make the process variable equal the setpoint.

It can operate as trim mode by summing the PI loop output with a master speed reference.

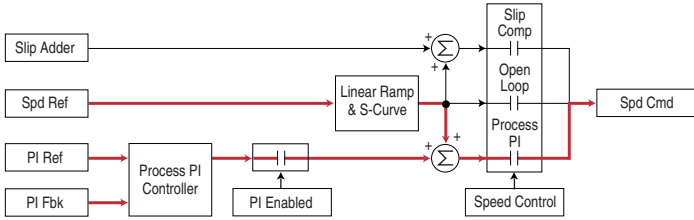

Or, it can operate as control mode by supplying the entire speed reference. This method is identified as “exclusive mode”

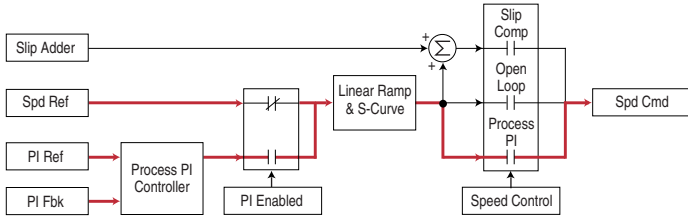

PI Enable

The output of the PI loop can be turned on (enabled) or turned off (disabled). This control allows the user to determine when the PI loop is providing part or all of the commanded speed. The logic for enabling the PI loop is shown below.

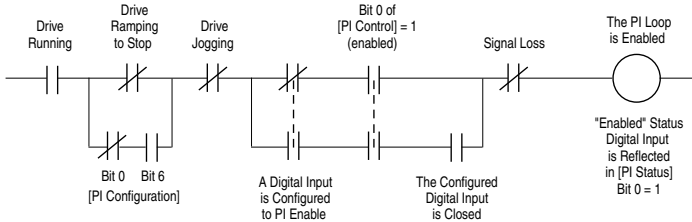

The drive must be running for the PI loop to be enabled. The loop will be disabled when the drive is ramping to a stop (unless “Stop Mode” is configured in [PI Configuration]), jogging or the signal loss protection for the analog input(s) is sensing a loss of signal.

If a digital input has been configured to “PI Enable,” two events are required to enable the loop: the digital input must be closed AND bit 0 of the PI Control parameter must be = 1.

If no digital input is configured to “PI Enable,” then only the Bit 0 = 1 condition must be met. If the bit is permanently set to a “1”, then the loop will become enabled as soon as the drive goes into “run”.

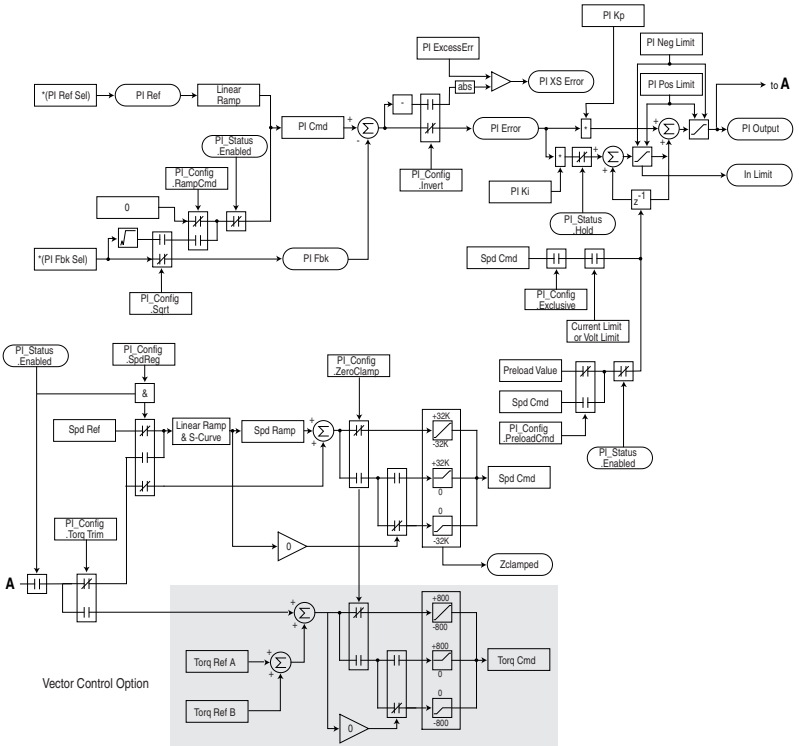
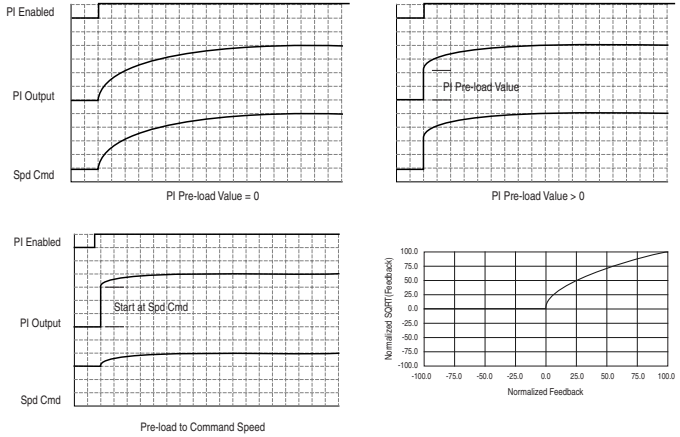

Reverse Speed Limit

Figure C.6 [Rev Speed Limit], parameter 454 set to zero

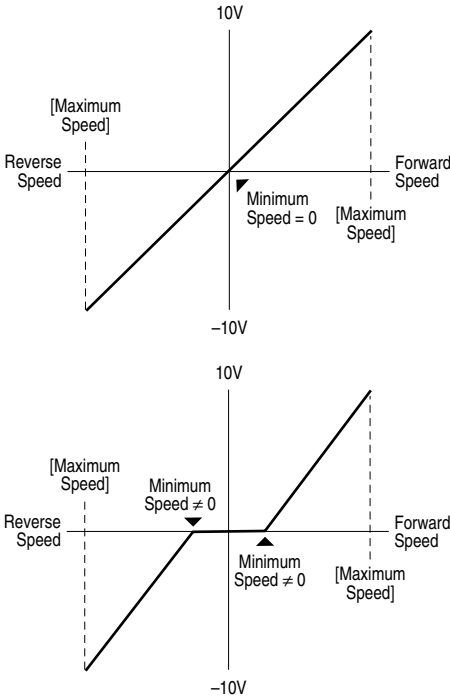
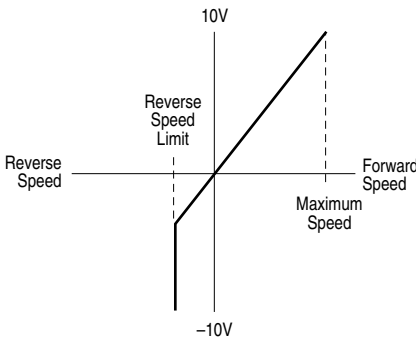
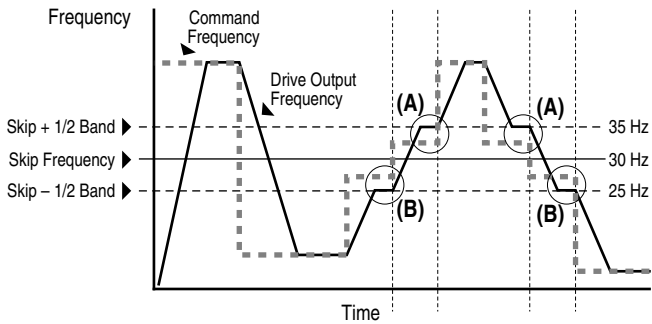

Figure C.7 [Rev Speed Limit], parameter 454 set to a non-zero Value



Skip Frequency

Figure C.8 Skip Frequency



Some machinery may have a resonant operating frequency that must be avoided to minimize the risk of equipment damage. To assure that the motor cannot continuously operate at one or more of the points, skip frequencies are used. Parameters 084-086, ([Skip Frequency 1-3]) are available to set the frequencies to be avoided.

The value programmed into the skip frequency parameters sets the center point for an entire “skip band” of frequencies. The width of the band (range of frequency around the center point) is determined by parameter 87, [Skip Freq Band]. The range is split, half above and half below the skip frequency parameter.

If the commanded frequency of the drive is greater than or equal to the skip (center) frequency and less than or equal to the high value of the band (skip plus 1/2 band), the drive will set the output frequency to the high value of the band. See (A) in [Figure C.8](#).

If the commanded frequency is less than the skip (center) frequency and greater than or equal to the low value of the band (skip minus 1/2 band), the drive will set the output frequency to the low value of the band. See (B) in [Figure C.8](#).

Acceleration and deceleration are not affected by the skip frequencies. Normal accel/decel will proceed through the band once the commanded frequency is greater than the skip frequency. See (A) & (B) in [Figure C.8](#). This function affects only continuous operation within the band.

Skip Frequency Examples

The skip frequency will have hysteresis so the output does not toggle between high and low values. Three distinct bands can be programmed. If none of the skip bands touch or overlap, each band has its own high/low limit.

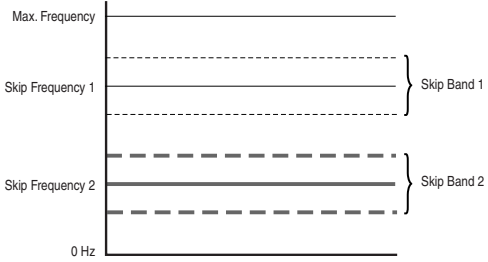

If skip bands overlap or touch, the center frequency is recalculated based on the highest and lowest band values.

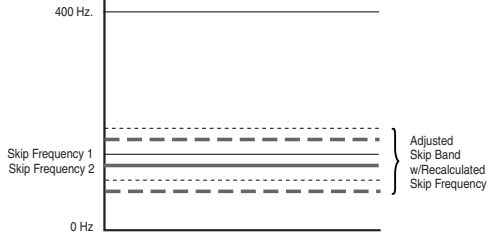

If a skip band(s) extend beyond the max frequency limits, the highest band value will be clamped at the max frequency limit. The center frequency is recalculated based on the highest and lowest band values.

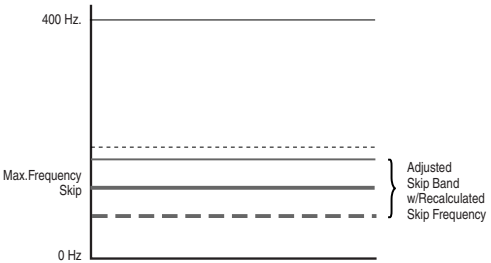

If the band is outside the limits, the skip band is inactive.

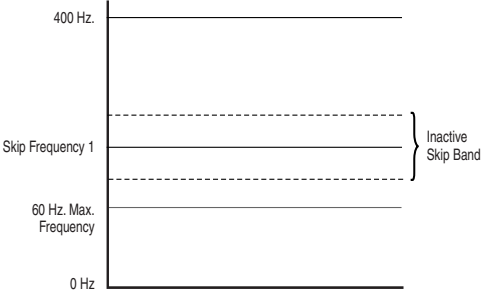

Sleep Wake Mode

This function stops (sleep) and starts (wake) the drive based on separately configurable analog input levels rather than discrete start and stop signals. When enabled in “Direct” mode, the drive will start (wake) when an analog signal is greater than or equal to the user specified [Wake Level], and stop the drive when an analog signal is less than or equal to the user specified [Sleep Level]. When Sleep Wake is enabled for “Invert” mode⁽¹⁾, the drive will start (wake) when an analog signal is less than or equal to the user specified [Wake Level], and stop the drive when an analog signal is greater than or equal to the user specified [Sleep Level].

Definitions

- **Wake** - A start command generated when the analog input value remains above [Wake Level] (or below when Invert mode is active) for a time greater than [Wake Time].
- **Sleep** - A Stop command generated when the analog input value remains below [Sleep Level] (or above when Invert mode is active) for a time greater than [Sleep Time].
- **Speed Reference** – The active speed command to the drive as selected by drive logic and [Speed Ref x Sel].
- **Start Command** - A command generated by pressing the Start button on the HIM, closing a digital input programmed for Start, Run, Run Forward or Run Reverse.

Refer to [Figure C.9](#).

⁽¹⁾ Invert mode is only available with Vector firmware 3.xxx and later.

Figure C.9 Sleep Wake Mode

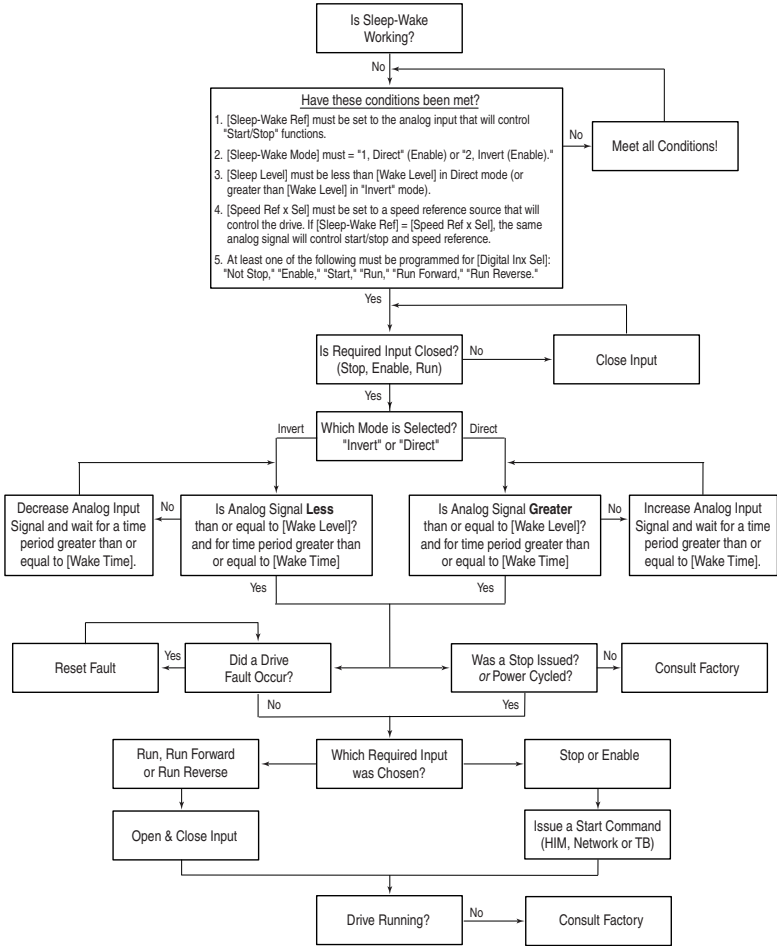

Start At PowerUp

Standard Control Option

When Start At Powerup in 2 wire control is configured, the drive will start if the start permissive conditions are met within 10 seconds of drive power being applied. An alarm will be annunciated from application of power until the drive actually starts, indicating the powerup start attempt is in progress. If the drive has not started within the 10 second interval, the powerup start attempt will be terminated.

Vector Control Option

A powerup delay time of up to 30 seconds can be programmed through [Powerup Delay], parameter 167. After the time expires, the drive will start if all of the start permissive conditions are met. Before that time, restart is not possible.

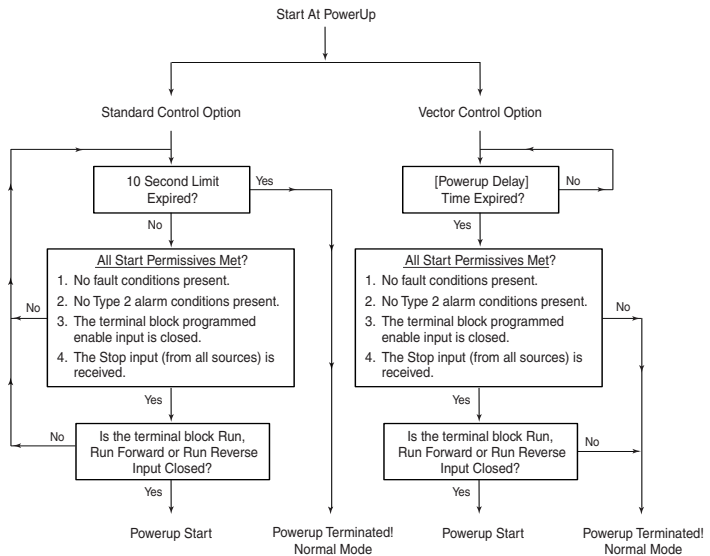

Stop Mode

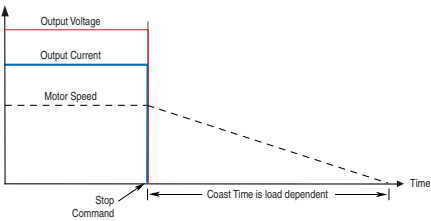
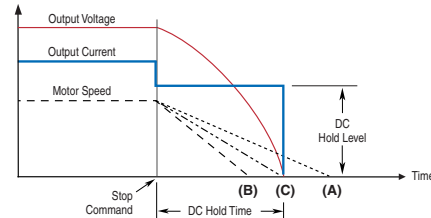
Mode	Description
Coast to Stop	 <p>This method releases the motor and allows the load to stop by friction.</p> <ol style="list-style-type: none"> 1. On Stop, the drive output goes immediately to zero (off). 2. No further power is supplied to the motor. The drive has released control. 3. The motor will coast for a time that is dependent on the mechanics of the system (inertia, friction, etc).
Brake to Stop	 <p>This method uses DC injection of the motor to Stop and/or hold the load.</p> <ol style="list-style-type: none"> 1. On Stop, 3 phase drive output goes to zero (off) 2. Drive outputs DC voltage on the last used phase at the level programmed in [DC Brake Level] Par 158. This voltage causes a “stopping” brake torque. If the voltage is applied for a time that is longer than the actual possible stopping time, the remaining time will be used to attempt to hold the motor at zero speed. 3. DC voltage to the motor continues for the amount of time programmed in [DC Brake Time] Par 159. Braking ceases after this time expires. 4. After the DC Braking ceases, no further power is supplied to the motor. The motor may or may not be stopped. The drive has released control. 5. The motor, if rotating, will coast from its present speed for a time that is dependent on the mechanics of the system (inertia, friction, etc).

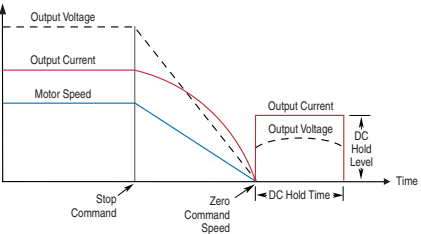
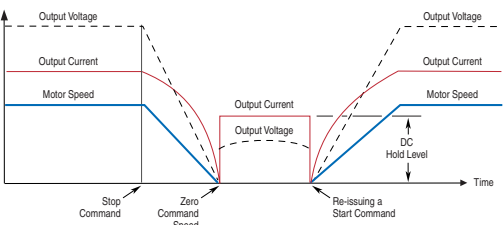
Mode	Description
<p>Ramp to Stop</p>	 <p>This method uses drive output reduction to stop the load.</p> <ol style="list-style-type: none"> 1. On Stop, drive output will decrease according to the programmed pattern from its present value to zero. The pattern may be linear or squared. The output will decrease to zero at the rate determined by the programmed [Maximum Freq] and the programmed active [Decel Time x]. 2. The reduction in output can be limited by other drive factors such as bus or current regulation. 3. When the output reaches zero the output is shut off. 4. The motor, if rotating, will coast from its present speed for a time that is dependent on the mechanics of the system (inertia, friction, etc).
<p>Ramp to Hold</p>	 <p>This method combines two of the methods above. It uses drive output reduction to stop the load and DC injection to hold the load at zero speed once it has stopped.</p> <ol style="list-style-type: none"> 1. On Stop, drive output will decrease according to the programmed pattern from its present value to zero. The pattern may be linear or squared. The output will decrease to zero at the rate determined by the programmed [Maximum Freq] and the programmed active [Decel Time x] 2. The reduction in output can be limited by other drive factors such as bus or current regulation. 3. When the output reaches zero 3 phase drive output goes to zero (off) and the drive outputs DC voltage on the last used phase at the level programmed in [DC Brake Level] Par 158. This voltage causes a “holding” brake torque. 4. DC voltage to the motor continues until a Start command is reissued or the drive is disabled. 5. If a Start command is reissued, DC Braking ceases and the drive returns to normal AC operation. If an Enable command is removed, the drive enters a “not ready” state until the enable is restored.

Voltage Tolerance

Drive Rating	Nominal Line Voltage	Nominal Motor Voltage	Drive Full Power Range	Drive Operating Range
200-240	200	200*	200-264	180-264
	208	208	208-264	
	240	230	230-264	
380-400	380	380*	380-528	342-528
	400	400	400-528	
	480	460	460-528	
500-600 <i>(Frames 0-4 Only)</i>	600	575*	575-660	432-660
500-690 <i>(Frames 5-6 Only)</i>	600	575*	575-660	475-759
	690	690	690-759	475-759

Drive Full Power Range = Nominal Motor Voltage to Drive Rated Voltage +10%.
Rated power is available across the entire Drive Full Power Range.

Drive Operating Range = Lowest (*) Nominal Motor Voltage -10% to Drive Rated Voltage +10%.
Drive Output is linearly derated when Actual Line Voltage is less than the Nominal Motor Voltage.

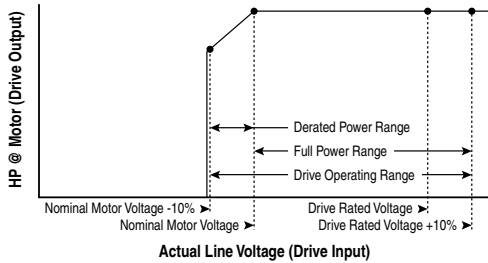

Example:

Calculate the maximum power of a 5 HP, 460V motor connected to a 480V rated drive supplied with 342V Actual Line Voltage input.

- Actual Line Voltage / Nominal Motor Voltage = 74.3%
- $74.3\% \times 5 \text{ HP} = 3.7 \text{ HP}$
- $74.3\% \times 60 \text{ Hz} = 44.6 \text{ Hz}$

At 342V Actual Line Voltage, the maximum power the 5 HP, 460V motor can produce is 3.7 HP at 44.6 Hz.

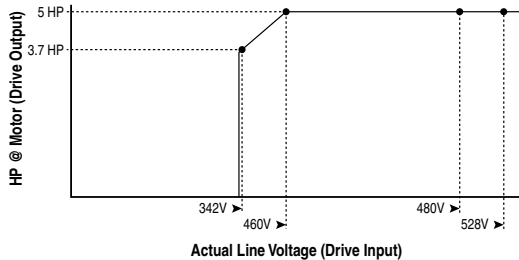

Numerics

32 Bit Parameters, **1-2**

A

Accel Mask, **1-52**

Accel Owner, **1-53**

Accel Time x, **1-31**

Alarm & Fault Types, **2-1**

Alarm 1 @ Fault, **1-45**

Alarm 2 @ Fault, **1-46**

Alarm Clear, **1-48**

Alarm Config 1, **1-48**

Alarm Descriptions, **2-10**

Alarm x Code, **1-48**

Alarms

Analog In Loss, **2-10**

Bipolar Conflict, **2-10**

Brake Slipped, **2-10**

Decel Inhibit, **2-10**

Dig In Conflict, **2-10**

Drive OL Level, **2-10**

FluxAmpsRef Rang, **2-11**

Ground Warn, **2-11**

In Phase Loss, **2-11**

IntDBRes OvrHeat, **2-11**

IR Volts Range, **2-11**

Ixo Vlt Rang, **2-11**

Load Loss, **2-11**

MaxFreq Conflict, **2-11**

Motor Thermistor, **2-11**

Motor Type Cflct, **2-11**

NP Hz Conflict, **2-11**

Power Loss, **2-11**

Precharge Active, **2-11**

PTC Conflict, **2-11**

Sleep Config, **2-11**

Speed Ref Cflct, **2-11**

Start At PowerUp, **2-11**

TB Man Ref Cflct, **2-12**

Torq Prove Cflct, **2-12**

UnderVoltage, **2-12**

VHz Neg Slope, **2-12**

Waking, **2-12**

Alarms Group, **1-48**

Alarms, Clearing, **2-9**

ALT Key

Functions, **B-2**

ALT Key Functions, **B-2**

Analog In Loss Alarm, **2-10**

Analog In Loss Fault, **2-4**

Analog In x Hi, **1-55**

Analog In x Lo, **1-55**

Analog Inputs Group, **1-54**

Analog Inx Value, **1-13**

Analog Out Scale, **1-57**

Analog Out1 Hi, **1-56**

Analog Out1 Lo, **1-56**

Analog Out1 Sel, **1-56**

Analog Out2 Lo, **1-56**

Analog Out2 Sel, **1-56**

Analog Outputs Group, **1-55**

Anlg Cal Chksum Fault, **2-4**

Anlg In Config, **1-54**

Anlg In Loss, **1-55**

Anlg In Sqr Root, **1-54**

Anlg Out Absolut, **1-55**

Anlg Out Config, **1-55**

Anlg Out Setpt, **1-57**

Applications File, **1-60**

Auto Rstrt Delay, **1-35**

Auto Rstrt Tries, **1-35**

Auto Rstrt Tries Fault, **2-4**

Auto-Reset/Start, **2-1**

Autotune, **1-17**

AutoTune Aborted Fault, **2-4**

Autotune Torque, **1-18**

Auxiliary Input Fault, **2-4**

B

Bipolar Conflict Alarm, **2-10**

Brake

Dynamic, **1-33**

Brake Slipped Alarm, **2-10**

Break Frequency, **1-20**

Break Voltage, **1-20**

Brk Alarm Travel, **1-61**

Brk Release Time, **1-61**

Brk Set Time, **1-61**

BrkSlip Count, **1-61**

Bus Capacitors, Discharging, **P-3**

Bus Reg Kd, **1-34**

Bus Reg Ki, **1-33**

Bus Reg Kp, **1-34**

Bus Reg Mode A, **1-33**

Bus Reg Mode B, **1-33**

C

Capacitors

Bus, Discharging, **P-3**

Catalog Number Explanation, **P-5**

Clear Fault Owner, **1-53**

Clearing Alarms, **2-9**

Clearing Faults, **2-3**

Cntl Bd Overtemp Fault, **2-4**

Comm Control Group, **1-50**

Commanded Freq, **1-12**

Commanded Speed, **1-12**

Commanded Torque, **1-13**

Common Symptoms and Corrective Action, **2-13**

Communication File, **1-50**

Communications

Logic Command Word, **A-3**

Logic Status Word, **A-4**

Programmable Controller Configurations, **A-2**

Compensation, **1-16**

Control Options, **1-3**

Control Status, **1-19**

Control SW Ver, **1-14**

Conventions, Manual, **P-2**

Copycat, **B-4**

Cross Reference, Parameter

by Name, **1-61**

by Number, **1-64**

Current Lmt Gain, **1-31**

Current Lmt Sel, **1-31**

Current Lmt Val, **1-31**

Current Rate Limit, **1-32**

D

Data In Ax, **1-53**

Data Out Ax, **1-54**

Data, Saving, **B-4**

Datalinks Group, **1-53**

DB Resistance Fault, **2-4**

DB Resistor Type, **1-34**

DB While Stopped, **1-32**

DC Brake Level, **1-33**

DC Brake Time, **1-33**

DC Brk Lvl Sel, **1-32**

DC Bus Memory, **1-13**

DC Bus Voltage, **1-13**

Decel Inhibit Fault, **2-5**

Decel Inhibit Alarm, **2-10**

Decel Mask, **1-52**

Decel Owner, **1-53**

Decel Time x, **1-31**

Defaults, Resetting to, **1-40, B-4**

Diagnostic Data, Viewing, **B-4**

Diagnostics Group, **1-41**

Dig In Conflict Alarm, **2-10**

Dig In Status, **1-44**

Dig Out Setpt, **1-59**

Dig Out Status, **1-44**

Dig Outx Level, **1-59**

Dig Outx OffTime, **1-60**

Dig Outx OnTime, **1-60**

Digital Inputs Group, **1-58**

Digital Inx Sel, **1-58**

Digital Outputs Group, **1-58**

Digital Outx Sel, **1-59**

Direction Config Group, **1-38**

Direction Mask, **1-52**

Direction Mode, **1-38**

Direction Owner, **1-53**

Discrete Speeds Group, **1-25**

DPI Baud Rate, **1-50**

DPI Data Rate, **1-50**

DPI Fdbk Select, **1-51**

DPI Port 1-5 Fault, **2-7**

DPI Port Locations, **B-1**

DPI Port Sel, **1-51**

DPI Port Value, **1-51**

DPI Ref Select, **1-51**

Drive Alarm 1, **1-42**

Drive Alarm 2, **1-42**

Drive Checksum, **1-41**

Drive Data Group, **1-14**

Drive Frame Size, **A-1**

Drive Logic Rslt, **1-50**

Drive Memory Group, **1-39**

Drive OL Count, **1-44**

Drive OL Level Alarm, **2-10**

Drive OL Mode, **1-31**

Drive Overload Fault, **2-5**

Drive Powerup Fault, **2-5**

Drive Ramp Rslt, **1-50**

Drive Ref Rslt, **1-50**

Drive Status 1, **1-41**

Drive Temp, **1-44**

DriveExecutive, **1-1**
DriveExplorer, **1-1**
Droop RPM @ FLA, **1-32**
Dynamic Brake
 Resistor Selection, **1-34**
 Setup, **1-33**
Dynamic Control File, **1-31**

E

Editing Parameters, **1-1**
Elapsed kWh, **1-13**
Elapsed MWH, **1-12**
Elapsed Run Time, **1-12**
Enc Position Fdbk, **1-20**
Encoder Loss Fault, **2-5**
Encoder PPR, **1-20**
Encoder Quad Err Fault, **2-5**
Encoder Speed, **1-20**
Encoder Z Chan, **1-21**
ESD, Static Discharge, **P-3**
Excessive Load Fault, **2-5**
External Brake Resistor, **C-1**

F

Factory Defaults, Resetting to, **1-40**,
 B-4
Fan/Pump Parameter Set, **1-39**
Fault & Alarm Types, **2-1**
Fault 1 Time, **1-48**
Fault Amps, **1-44**
Fault Bus Volts, **1-45**
Fault Clear, **1-46**
Fault Clear Mode, **1-47**
Fault Ctr Mask, **1-52**
Fault Config x, **1-46**
Fault Descriptions, **2-4**
Fault Frequency, **1-44**
Fault Queue, **B-4**
Fault Speed, **1-44**
Fault x Code, **1-47**
Faults
 Analog In Loss, **2-4**
 Anlg Cal Chksum, **2-4**
 Auto Rstrt Tries, **2-4**
 AutoTune Aborted, **2-4**
 Auxiliary Input, **2-4**
 Cntl Bd Overtemp, **2-4**
 DB Resistance, **2-4**
 Decel Inhibit, **2-5**

DPI Port 1-5, **2-7**
Drive Overload, **2-5**
Drive Powerup, **2-5**
Encoder Loss, **2-5**
Encoder Quad Err, **2-5**
Excessive Load, **2-5**
Faults Cleared, **2-5**
Flt QueueCleared, **2-5**
FluxAmpsRef Rang, **2-5**
Ground Fault, **2-5**
Hardware Fault, **2-5**
Heatsink OvrTemp, **2-5**
HW OverCurrent, **2-6**
I/O Comm Loss, **2-6**
I/O Failure, **2-6**
I/O Mismatch, **2-6**
Incompat MCB-PB, **2-6**
Input Phase Loss, **2-6**
IR Volts Range, **2-6**
IXo VoltageRange, **2-6**
Load Loss, **2-6**
Motor Overload, **2-6**
Motor Thermistor, **2-6**
NVS I/O Checksum, **2-6**
NVS I/O Failure, **2-6**
Output PhaseLoss, **2-7**
OverSpeed Limit, **2-7**
OverVoltage, **2-7**
Parameter Chksum, **2-7**
Params Defaulted, **2-7**
Phase Short, **2-7**
Phase to Grnd, **2-7**
Port 1-5 DPI Loss, **2-7**
Power Loss, **2-8**
Power Unit, **2-8**
Pulse In Loss, **2-8**
Pwr Brd Chksum, **2-8**
Pwr Brd Chksum2, **2-8**
Replaced MCB-PB, **2-8**
Shear Pin, **2-8**
Software, **2-8**
SW OverCurrent, **2-8**
TorqPrv Spd Band, **2-8**
Trnsistr OvrTemp, **2-8**
UnderVoltage, **2-9**
UserSet Chksum, **2-9**
Faults Cleared Fault, **2-5**
Faults Group, **1-46**
Faults, Clearing, **2-3**
Fdbk Filter Sel, **1-20**
Feedback Select, **1-22**
FGP, **1-3**
File

- Applications, **1-60**
- Communication, **1-50**
- Dynamic Control, **1-31**
- Inputs & Outputs, **1-54**
- Monitor, **1-12**
- Motor Control, **1-14**
- Speed Command, **1-21**
- Utility, **1-38**
- File-Group-Parameter, **1-3**
- Float Tolerance, **1-61**
- Fit QueueCleared Fault, **2-5**
- Flux Braking, **1-34**
- Flux Current, **1-12**
- Flux Current Ref, **1-17**
- Flux Up Mode, **1-16**
- Flux Up Time, **1-16**
- Flux Vector Control Option, **1-3**
- FluxAmpsRef Rang Alarm, **2-11**
- FluxAmpsRef Rang Fault, **2-5**
- Flying Start En, **1-35**
- Flying StartGain, **1-35**
- Frame Size, Drive, **A-1**
- Functions, ALT Key, **B-2**

G

- General Precautions, **P-3**
- Gnd Warn Level, **1-37**
- Ground Fault, **2-5**
- Ground Warn Alarm, **2-11**
- Group
 - Alarms, **1-48**
 - Analog Inputs, **1-54**
 - Analog Outputs, **1-55**
 - Comm Control, **1-50**
 - Datalinks, **1-53**
 - Diagnostics, **1-41**
 - Digital Inputs, **1-58**
 - Digital Outputs, **1-58**
 - Direction Config, **1-38**
 - Discrete Speeds, **1-25**
 - Drive Data, **1-14**
 - Drive Memory, **1-39**
 - Faults, **1-46**
 - HIM Ref Config, **1-39**
 - Load Limits, **1-31**
 - Masks & Owners, **1-51**
 - Metering, **1-12**
 - MOP Config, **1-39**
 - Motor Data, **1-14**
 - Power Loss, **1-37**
 - Process PI, **1-27**

- Ramp Rates, **1-31**
- Restart Modes, **1-34**
- Scaled Blocks, **1-49**
- Slip Comp, **1-26**
- Spd Mode & Limits, **1-21**
- Speed Feedback, **1-20**
- Speed References, **1-24**
- Speed Regulator, **1-29**
- Speed Trim, **1-26**
- Stop/Brake Modes, **1-32**
- Torq Attributes, **1-15**
- Volts per Hertz, **1-19**

H

- Hardware Fault, **2-5**
- Heatsink OvrTemp Fault, **2-5**
- HIM Menu Structure, **B-4**
- HIM Menus
 - Diagnostics, **B-4**
 - Memory Storage, **B-4**
 - Preferences, **B-4**
- HIM Ref Config Group, **1-39**
- HIM, Removing/Installing, **B-8**
- HW OverCurrent Fault, **2-6**

I

- I/O Comm Loss Fault, **2-6**
- I/O Failure Fault, **2-6**
- I/O Mismatch Fault, **2-6**
- In Phase Loss Alarm, **2-11**
- Incompat MCB-PB Fault, **2-6**
- Inertia Autotune, **1-18**
- Input Phase Loss Fault, **2-6**
- Inputs & Outputs File, **1-54**
- IntDBRes OvrHeat Alarm, **2-11**
- IR Voltage Drop, **1-17**
- IR Volts Range Alarm, **2-11**
- IR Volts Range Fault, **2-6**
- Ixo Vlt Rang Alarm, **2-11**
- Ixo Voltage Drop, **1-17**
- IXo VoltageRange Fault, **2-6**

J

- Jog Mask, **1-52**
- Jog Owner, **1-52**
- Jog Speed, **1-25**

K

Kf Speed Loop, **1-30**
Ki Speed Loop, **1-29**
Kp Speed Loop, **1-30**

L

Language, **1-40**
Last Stop Source, **1-43**
LCD HIM
 Menus, **B-4**
LEDs, **2-2**
Lifting/Torque Proving, **C-2**
Linear List, **1-3**
Linking Parameters, **B-6**
Load Frm Usr Set, **1-2, 1-40**
Load Limits Group, **1-31**
Load Loss Alarm, **2-11**
Load Loss Fault, **2-6**
Load Loss Level, **1-38**
Load Loss Time, **1-38**
Local Mask, **1-52**
Local Owner, **1-53**
Logic Command Word, **A-3**
Logic Mask, **1-51**
Logic Status Word, **A-4**

M

Man Ref Preload, **1-39**
Manual Conventions, **P-2**
Marker Pulse, **1-21**
Masks & Owners Group, **1-51**
MaxFreq Conflict Alarm, **2-11**
Maximum Freq, **1-16**
Maximum Speed, **1-22**
Maximum Voltage, **1-15**
Menu Structure, HIM, **B-4**
Metering Group, **1-12**
MicroPos Scale%, **1-61**
Minimum Speed, **1-22, C-7**
MOD LED, **2-2**
Monitor File, **1-12**
MOP Config Group, **1-39**
MOP Frequency, **1-13**
MOP Mask, **1-52**
MOP Owner, **1-53**
MOP Rate, **1-39**
MOP Reference, **1-13**

Motor Cntl Sel, **1-15**
Motor Control File, **1-14**
Motor Control Technology, **C-8**
Motor Data Group, **1-14**
Motor Fdbk Type, **1-20**
Motor NP FLA, **1-14**
Motor NP Hertz, **1-14**
Motor NP Power, **1-15**
Motor NP RPM, **1-14**
Motor NP Volts, **1-14**
Motor OL Count, **1-44**
Motor OL Factor, **1-15**
Motor OL Hertz, **1-15**
Motor Overload, **C-10**
Motor Overload Fault, **2-6**
Motor Poles, **1-15**
Motor Thermistor Alarm, **2-11**
Motor Thermistor Fault, **2-6**
Motor Type, **1-14**
Motor Type Cflct Alarm, **2-11**
Mtr NP Pwr Units, **1-15**
Mtr Tor Cur Ref, **1-19**

N

Neg Torque Limit, **1-19**
NET LED, **2-2**
Non-Resettable, **2-1**
Notch Filter Freq, **1-20**
Notch Filter K, **1-21**
NP Hz Conflict Alarm, **2-11**
NVS I/O Checksum Fault, **2-6**
NVS I/O Failure Fault, **2-6**

O

Operator Interface, **B-5**
Output Current, **1-12**
Output Freq, **1-12**
Output PhaseLoss Fault, **2-7**
Output Power, **1-12**
Output Powr Fctr, **1-12**
Output Voltage, **1-12**
Overspeed, **C-11**
Overspeed Limit, **1-22**
OverSpeed Limit Fault, **2-7**
OverVoltage Fault, **2-7**

P

- Param Access Lvl, **1-39**
- Parameter
 - Changing/Editing, **B-5**
 - Descriptions, **1-1**
 - File-Group-Parameter Organization, **1-3**
 - Linear List, **1-3**
 - Viewing, **B-5**
- Parameter Chksum Fault, **2-7**
- Parameter Cross Reference
 - by Name, **1-61**
 - by Number, **1-64**
- Parameter Linking, **B-6**
- Parameter View
 - Advanced
 - Standard Control, **1-6**
 - Fan/Pump, **1-11**
 - Vector Control, **1-8**
 - Basic
 - Standard Control, **1-4**
 - Fan/Pump, **1-10**
 - Vector Control, **1-5**
- Parameters
 - Accel Mask, **1-52**
 - Accel Owner, **1-53**
 - Accel Time x, **1-31**
 - Alarm 1 @ Fault, **1-45**
 - Alarm 2 @ Fault, **1-46**
 - Alarm Clear, **1-48**
 - Alarm Config 1, **1-48**
 - Alarm x Code, **1-48**
 - Analog In x Hi, **1-55**
 - Analog In x Lo, **1-55**
 - Analog Inx Value, **1-13**
 - Analog Out Scale, **1-57**
 - Analog Out1 Hi, **1-56**
 - Analog Out1 Lo, **1-56**
 - Analog Out1 Sel, **1-56**
 - Analog Out2 Hi, **1-56**
 - Analog Out2 Lo, **1-56**
 - Analog Out2 Sel, **1-56**
 - Anlg In Config, **1-54**
 - Anlg In Loss, **1-55**
 - Anlg In Sqr Root, **1-54**
 - Anlg Out Absolut, **1-55**
 - Anlg Out Config, **1-55**
 - Anlg Out Setpt, **1-57**
 - Auto Rstrt Delay, **1-35**
 - Auto Rstrt Tries, **1-35**
 - Autotune, **1-17**
 - Autotune Torque, **1-18**
 - Break Frequency, **1-20**
 - Break Voltage, **1-20**
 - Brk Alarm Travel, **1-61**
 - Brk Release Time, **1-61**
 - Brk Set Time, **1-61**
 - BrkSlip Count, **1-61**
 - Bus Reg Kd, **1-34**
 - Bus Reg Ki, **1-33**
 - Bus Reg Kp, **1-34**
 - Bus Reg Mode A, **1-33**
 - Bus Reg Mode B, **1-33**
 - Clear Fault Owner, **1-53**
 - Commanded Freq, **1-12**
 - Commanded Speed, **1-12**
 - Commanded Torque, **1-13**
 - Compensation, **1-16**
 - Control Status, **1-19**
 - Control SW Ver, **1-14**
 - Current Lmt Gain, **1-31**
 - Current Lmt Sel, **1-31**
 - Current Lmt Val, **1-31**
 - Current Rate Limit, **1-32**
 - Data In Ax, **1-53**
 - Data Out Ax, **1-54**
 - DB Resistor Type, **1-34**
 - DB While Stopped, **1-32**
 - DC Brake Level, **1-33**
 - DC Brake Time, **1-33**
 - DC Brk Lvl Sel, **1-32**
 - DC Bus Memory, **1-13**
 - DC Bus Voltage, **1-13**
 - Decel Mask, **1-52**
 - Decel Owner, **1-53**
 - Decel Time x, **1-31**
 - Dig In Status, **1-44**
 - Dig Out Setpt, **1-59**
 - Dig Out Status, **1-44**
 - Dig Outx Level, **1-59**
 - Dig Outx OffTime, **1-60**
 - Dig Outx OnTime, **1-60**
 - Digital Inx Sel, **1-58**
 - Digital Outx Sel, **1-59**
 - Direction Mask, **1-52**
 - Direction Mode, **1-38**
 - Direction Owner, **1-53**
 - DPI Baud Rate, **1-50**
 - DPI Data Rate, **1-50**
 - DPI Fdbk Select, **1-51**
 - DPI Port Sel, **1-51**
 - DPI Port Value, **1-51**
 - DPI Ref Select, **1-51**
 - Drive Alarm 1, **1-42**
 - Drive Alarm 2, **1-42**
 - Drive Checksum, **1-41**

- Drive Logic Rslt, **1-50**
- Drive OL Count, **1-44**
- Drive OL Mode, **1-31**
- Drive Ramp Rslt, **1-50**
- Drive Ref Rslt, **1-50**
- Drive Status 1, **1-41**
- Drive Temp, **1-44**
- Droop RPM @ FLA, **1-32**
- Elapsed kWh, **1-13**
- Elapsed MWH, **1-12**
- Elapsed Run Time, **1-12**
- Enc Position Fdbk, **1-20**
- Encoder PPR, **1-20**
- Encoder Speed, **1-20**
- Encoder Z Chan, **1-21**
- Fault 1 Time, **1-48**
- Fault Amps, **1-44**
- Fault Bus Volts, **1-45**
- Fault Clear, **1-46**
- Fault Clear Mode, **1-47**
- Fault Clr Mask, **1-52**
- Fault Config x, **1-46**
- Fault Frequency, **1-44**
- Fault Speed, **1-44**
- Fault x Code, **1-47**
- Fdbk Filter Sel, **1-20**
- Feedback Select, **1-22**
- Float Tolerance, **1-61**
- Flux Braking, **1-34**
- Flux Current, **1-12**
- Flux Current Ref, **1-17**
- Flux Up Mode, **1-16**
- Flux Up Time, **1-16**
- Flying Start En, **1-35**
- Flying StartGain, **1-35**
- Gnd Warn Level, **1-37**
- Inertia Autotune, **1-18**
- IR Voltage Drop, **1-17**
- Ixo Voltage Drop, **1-17**
- Jog Mask, **1-52**
- Jog Owner, **1-52**
- Jog Speed, **1-25**
- Kf Speed Loop, **1-30**
- Ki Speed Loop, **1-29**
- Kp Speed Loop, **1-30**
- Language, **1-40**
- Last Stop Source, **1-43**
- Load Frm Usr Set, **1-2, 1-40**
- Load Loss Level, **1-38**
- Load Loss Time, **1-38**
- Local Mask, **1-52**
- Local Owner, **1-53**
- Logic Mask, **1-51**
- Man Ref Preload, **1-39**
- Marker Pulse, **1-21**
- Maximum Freq, **1-16**
- Maximum Speed, **1-22**
- Maximum Voltage, **1-15**
- MicroPos Scale%, **1-61**
- Minimum Speed, **1-22**
- MOP Frequency, **1-13**
- MOP Mask, **1-52**
- MOP Owner, **1-53**
- MOP Rate, **1-39**
- MOP Reference, **1-13**
- Motor Cntl Sel, **1-15**
- Motor Fdbk Type, **1-20**
- Motor NP FLA, **1-14**
- Motor NP Hertz, **1-14**
- Motor NP Power, **1-15**
- Motor NP RPM, **1-14**
- Motor NP Volts, **1-14**
- Motor OL Count, **1-44**
- Motor OL Factor, **1-15**
- Motor OL Hertz, **1-15**
- Motor Poles, **1-15**
- Motor Type, **1-14**
- Mtr NP Pwr Units, **1-15**
- Mtr Tor Cur Ref, **1-19**
- Neg Torque Limit, **1-19**
- Notch Filter Freq, **1-20**
- Notch Filter K, **1-21**
- Output Current, **1-12**
- Output Freq, **1-12**
- Output Power, **1-12**
- Output Powr Fctr, **1-12**
- Output Voltage, **1-12**
- Overspeed Limit, **1-22**
- Param Access Lvl, **1-39**
- PI BW Filter, **1-29**
- PI Configuration, **1-27**
- PI Control, **1-27**
- PI Deriv Time, **1-29**
- PI Error Meter, **1-29**
- PI Fdbk Meter, **1-28**
- PI Feedback Hi, **1-29**
- PI Feedback Lo, **1-29**
- PI Feedback Sel, **1-28**
- PI Integral Time, **1-28**
- PI Lower Limit, **1-28**
- PI Output Meter, **1-29**
- PI Preload, **1-28**
- PI Prop Gain, **1-28**
- PI Ref Meter, **1-28**
- PI Reference Hi, **1-29**
- PI Reference Lo, **1-29**
- PI Reference Sel, **1-27**
- PI Setpoint, **1-27**

- PI Status, **1-28**
- PI Upper Limit, **1-28**
- Pos Torque Limit, **1-19**
- Power Loss Level, **1-38**
- Power Loss Mode, **1-37**
- Power Loss Time, **1-37**
- Powerup Delay, **1-34**
- PowerUp Marker, **1-47**
- Preset Speed x, **1-25**
- Pulse In Scale, **1-21**
- Pulse Input Ref, **1-25**
- PWM Frequency, **1-31**
- Ramped Speed, **1-13**
- Rated Amps, **1-14**
- Rated kW, **1-14**
- Rated Volts, **1-14**
- Reference Mask, **1-52**
- Reference Owner, **1-53**
- Regen Power Limit, **1-32**
- Reset Meters, **1-40**
- Reset To Defaults, **1-40**
- Rev Speed Limit, **1-23**
- Run Boost, **1-19**
- S Curve %, **1-31**
- Save HIM Ref, **1-39**
- Save MOP Ref, **1-39**
- Save To User Set, **1-40**
- Scale In Hi, **1-49**
- Scale In Lo, **1-49**
- Scale In Value, **1-49**
- Scale Out Hi, **1-49**
- Scale Out Lo, **1-49**
- Scale Out Value, **1-49**
- Shear Pin Time, **1-38**
- Skip Freq Band, **1-23**
- Skip Frequency x, **1-23**
- Sleep Level, **1-37**
- Sleep Time, **1-37**
- Sleep-Wake Mode, **1-36**
- Sleep-Wake Ref, **1-37**
- Slip Comp Gain, **1-26**
- Slip RPM @ FLA, **1-26**
- Slip RPM Meter, **1-26**
- SpdBand Integrat, **1-61**
- Speed Desired BW, **1-30**
- Speed Dev Band, **1-61**
- Speed Feedback, **1-13**
- Speed Loop Meter, **1-30**
- Speed Mode, **1-22**
- Speed Ref A Hi, **1-24**
- Speed Ref A Lo, **1-24**
- Speed Ref A Sel, **1-24**
- Speed Ref B Hi, **1-24**
- Speed Ref B Lo, **1-24**
- Speed Ref B Sel, **1-24**
- Speed Ref Source, **1-43**
- Speed Reference, **1-13**
- Speed Units, **1-21**
- Speed/Torque Mod, **1-23**
- Start At PowerUp, **1-34**
- Start Inhibits, **1-43**
- Start Mask, **1-51**
- Start Owner, **1-52**
- Start/Acc Boost, **1-19**
- Status 1 @ Fault, **1-45**
- Stop Mode x, **1-32**
- Stop Owner, **1-52**
- Stop/BRK Mode x, **1-32**
- SV Boost Filter, **1-16**
- TB Man Ref Hi, **1-25**
- TB Man Ref Lo, **1-25**
- TB Man Ref Sel, **1-25**
- Testpoint 1 Sel, **1-46**
- Testpoint x Data, **1-46**
- Torq Ref A Div, **1-18**
- TorqLim SlewRate, **1-61**
- TorqProve Cnfg, **1-60**
- TorqProve Setup, **1-60**
- Torque Current, **1-12**
- Torque Perf Mode, **1-15**
- Torque Ref B Mult, **1-2, 1-18**
- Torque Ref x Hi, **1-18**
- Torque Ref x Lo, **1-18**
- Torque Ref x Sel, **1-18**
- Torque Setpoint, **1-19**
- Torque Setpoint2, **1-19**
- Total Inertia, **1-30**
- Trim % Setpoint, **1-26**
- Trim Hi, **1-26**
- Trim In Select, **1-26**
- Trim Lo, **1-26**
- Trim Out Select, **1-26**
- Voltage Class, **1-41**
- Wake Level, **1-37**
- Wake Time, **1-37**
- Zero SpdFloatTime, **1-61**
- Params Defaulted Fault, **2-7**
- Phase Short Fault, **2-7**
- Phase to Grnd Fault, **2-7**
- PI BW Filter, **1-29**
- PI Configuration, **1-27**
- PI Control, **1-27**
- PI Deriv Time, **1-29**
- PI Error Meter, **1-29**
- PI Fdbck Meter, **1-28**
- PI Feedback Hi, **1-29**

PI Feedback Lo, **1-29**
PI Feedback Sel, **1-28**
PI Integral Time, **1-28**
PI Lower Limit, **1-28**
PI Output Meter, **1-29**
PI Preload, **1-28**
PI Prop Gain, **1-28**
PI Ref Meter, **1-28**
PI Reference Hi, **1-29**
PI Reference Lo, **1-29**
PI Reference Sel, **1-27**
PI Setpoint, **1-27**
PI Status, **1-28**
PI Upper Limit, **1-28**
Port 1-5 DPI Loss Fault, **2-7**
PORT LED, **2-2**
Ports, DPI Type, **B-1**
Pos Torque Limit, **1-19**
Power Loss Alarm, **2-11**
Power Loss Fault, **2-8**
Power Loss Group, **1-37**
Power Loss Level, **1-38**
Power Loss Mode, **1-37**
Power Loss Ride Through, **C-12**
Power Loss Time, **1-37**
Power Unit Fault, **2-8**
Powerup Delay, **1-34**
PowerUp Marker, **1-47**
Precautions, General, **P-3**
Precharge Active Alarm, **2-11**
Preferences, Setting, **B-4**
Preset Speed x, **1-25**
Process PI
 Standard Control, **C-13**
Process PI Group, **1-27**
Programmable Controller
 Configurations, **A-2**
Programming, **1-1**
PTC Conflict Alarm, **2-11**
Publications, Reference, **P-2**
Pulse In Loss Fault, **2-8**
Pulse In Scale, **1-21**
Pulse Input Ref, **1-25**
PWM Frequency, **1-31**
Pwr Brd Chksum Fault, **2-8**
Pwr Brd Chksum2, **2-8**
PWR LED, **2-2**

R

Ramp Rates Group, **1-31**
Ramped Speed, **1-13**
Rated Amps, **1-14**
Rated kW, **1-14**
Rated Volts, **1-14**
Reference Mask, **1-52**
Reference Material, **P-2**
Reference Owner, **1-53**
Regen Power Limit, **1-32**
Replaced MCB-PB Fault, **2-8**
Reset Meters, **1-40**
Reset to Defaults, **1-40, B-4**
Restart Modes Group, **1-34**
Rev Speed Limit, **1-23**
Reverse Speed Limit, **C-16**
Run Boost, **1-19**

S

S Curve %, **1-31**
Save HIM Ref, **1-39**
Save MOP Ref, **1-39**
Save To User Set, **1-40**
Saving Data, **B-4**
Scale In Hi, **1-49**
Scale In Lo, **1-49**
Scale In Value, **1-49**
Scale Out Hi, **1-49**
Scale Out Lo, **1-49**
Scale Out Value, **1-49**
Scaled Blocks Group, **1-49**
Setting Preferences, **B-4**
Shear Pin Fault, **2-8**
Shear Pin Time, **1-38**
Skip Freq Band, **1-23**
Skip Frequency, **C-17**
Skip Frequency x, **1-23**
Sleep Config Alarm, **2-11**
Sleep Level, **1-37**
Sleep Time, **1-37**
Sleep Wake Mode, **C-19**
Sleep-Wake Mode, **1-36**
Sleep-Wake Ref, **1-37**
Slip Comp Gain, **1-26**
Slip Comp Group, **1-26**
Slip RPM @ FLA, **1-26**
Slip RPM Meter, **1-26**
Software Fault, **2-8**

Spd Mode & Limits Group, **1-21**
SpdBand Integrat, **1-61**
Speed Command File, **1-21**
Speed Desired BW, **1-30**
Speed Dev Band, **1-61**
Speed Feedback, **1-13**
Speed Feedback Group, **1-20**
Speed Loop Meter, **1-30**
Speed Mode, **1-22**
Speed Ref A Hi, **1-24**
Speed Ref A Lo, **1-24**
Speed Ref A Sel, **1-24**
Speed Ref B Hi, **1-24**
Speed Ref B Lo, **1-24**
Speed Ref B Sel, **1-24**
Speed Ref Cflct Alarm, **2-11**
Speed Ref Source, **1-43**
Speed Reference, **1-13**
Speed References Group, **1-24**
Speed Regulator Group, **1-29**
Speed Trim Group, **1-26**
Speed Units, **1-21**
Speed/Torque Mod, **1-23**
Standard Control Option, **1-3**
Start At PowerUp, **1-34, C-21**
Start At PowerUp Alarm, **2-11**
Start Inhibits, **1-43**
Start Mask, **1-51**
Start Owner, **1-52**
Start/Acc Boost, **1-19**
Static Discharge, ESD, **P-3**
Status 1 @ Fault, **1-45**
Status LEDs, **2-2**
Stop Mode x, **1-32**
Stop Owner, **1-52**
Stop/Brake Modes Group, **1-32**
Stop/BRK Mode x, **1-32**
STS LED, **2-2**
SV Boost Filter, **1-16**
SW OverCurrent Fault, **2-8**

T

TB Man Ref Cflct Alarm, **2-12**
TB Man Ref Hi, **1-25**
TB Man Ref Lo, **1-25**
TB Man Ref Sel, **1-25**
Testpoint 1 Sel, **1-46**
Testpoint Codes and Functions, **2-16**

Testpoint x Data, **1-46**
Torq Attributes Group, **1-15**
Torq Prove Cflct Alarm, **2-12**
Torq Ref A Div, **1-18**
TorqLim SlewRate, **1-61**
TorqProve Cnfg, **1-60**
TorqProve Setup, **1-60**
TorqPrv Spd Band Fault, **2-8**
Torque Current, **1-12**
Torque Perf Mode, **1-15**
Torque Proving, **C-2**
Torque Ref B Mult, **1-2, 1-18**
Torque Ref x Hi, **1-18**
Torque Ref x Lo, **1-18**
Torque Ref x Sel, **1-18**
Torque Setpoint, **1-19**
Torque Setpoint2, **1-19**
Total Inertia, **1-30**
Trim % Setpoint, **1-26**
Trim Hi, **1-26**
Trim In Select, **1-26**
Trim Lo, **1-26**
Trim Out Select, **1-26**
Trnsistr OvrTemp Fault, **2-8**
Troubleshooting, **2-1**

U

UnderVoltage
Alarm, **2-12**
Fault, **2-9**
User Configurable Alarm, **2-1**
User Sets, **B-4**
UserSet Chksum Fault, **2-9**
Utility File, **1-38**

V

VHz Neg Slope Alarm, **2-12**
Viewing and Changing Parameters, **B-5**
Voltage Class, **1-41**
Voltage Tolerance, **C-24**
Volts per Hertz Group, **1-19**

W

Wake Level, **1-37**
Wake Time, **1-37**
Waking Alarm, **2-12**
Web Sites, see *WWW, World Wide Web*

WWW, World Wide Web, **P-1**, **P-2**

Z

Zero SpdFloatTime, **1-61**

Notes:

PowerFlex 700 Parameter Record

Number	Parameter Name	Setting
40	Motor Type	
41	Motor NP Volts	
42	Motor NP FLA	
43	Motor NP Hertz	
44	Motor NP RPM	
45	Motor NP Power	
46	Mtr NP Pwr Units	
47	Motor OL Hertz	
48	Motor OL Factor	
49	Motor Poles	
53	Motor Cntl Sel	
	Torque Perf Mode	
54	Maximum Voltage	
55	Maximum Freq	
56	Compensation	
57	Flux Up Mode	
58	Flux Up Time	
59	SV Boost Filter	
61	Autotune	
62	IR Voltage Drop	
63	Flux Current Ref	
64	Ixo Voltage Drop	
66	Autotune Torque	
67	Inertia Autotune	
69	Start/Acc Boost	
70	Run Boost	
71	Break Voltage	
72	Break Frequency	
79	Speed Units	
80	Feedback Select	
	Speed Mode	
81	Minimum Speed	
82	Maximum Speed	
83	Overspeed Limit	
84-86	Skip Frequency X	
87	Skip Freq Band	
88	Speed/Torque Mod	
90, 93	Speed Ref X Sel	
91, 94	Speed Ref X Hi	
92, 95	Speed Ref X Lo	
96	TB Man Ref Sel	
97	TB Man Ref Hi	
98	TB Man Ref Lo	
100	Jog Speed	
	Jog Speed 1	
101-107	Preset Speed X	
108	Jog Speed 2	
116	Trim % Setpoint	
117	Trim In Select	
118	Trim Out Select	
119	Trim Hi	
120	Trim Lo	
121	Slip RPM @ FLA	
122	Slip Comp Gain	
124	PI Configuration	

Number	Parameter Name	Setting
125	PI Control	
126	PI Reference Sel	
127	PI Setpoint	
128	PI Feedback Sel	
129	PI Integral Time	
130	PI Prop Gain	
131	PI Lower Limit	
132	PI Upper Limit	
133	PI Preload	
139	PI BW Filter	
140, 141	Accel Time X	
142, 143	Decel Time X	
145	DB While Stopped	
146	S Curve %	
147	Current Lmt Sel	
148	Current Lmt Val	
149	Current Lmt Gain	
150	Drive OL Mode	
151	PWM Frequency	
152	Droop RPM @ FLA	
153	Regen Power Limit	
154	Current Rate Limit	
155, 156	Stop Mode X	
	Stop/BRK Mode X	
157	DC Brk Lvl Sel	
158	DC Brake Level	
159	DC Brake Time	
160	Bus Reg Ki	
161, 162	Bus Reg Mode X	
163	DB Resistor Type	
164	Bus Reg Kp	
165	Bus Reg Kd	
166	Flux Braking	
167	Powerup Delay	
168	Start At PowerUp	
169	Flying Start En	
170	Flying StartGain	
174	Auto Rstrt Tries	
175	Auto Rstrt Delay	
177	Gnd Warn Level	
178	Sleep-Wake Mode	
179	Sleep-Wake Ref	
180	Wake Level	
181	Wake Time	
182	Sleep Level	
183	Sleep Time	
184	Power Loss Mode	
185	Power Loss Time	
186	Power Loss Level	
187	Load Loss Level	
188	Load Loss Time	
189	Shear Pin Time	
190	Direction Mode	
192	Save HIM Ref	
193	Man Ref Preload	

Number	Parameter Name	Setting
194	Save MOP Ref	
195	MOP Rate	
196	Param Access Lvl	
197	Reset To Defaults	
198	Load Frm Usr Set	
199	Save To User Set	
200	Reset Meters	
201	Language	
202	Voltage Class	
234, 236	Testpoint X Sel	
238	Fault Config 1	
240	Fault Clear	
241	Fault Clear Mode	
259	Alarm Config 1	
261	Alarm Clear	
270	DPI Baud Rate	
	DPI Data Rate	
274	DPI Port Sel	
276	Logic Mask	
277	Start Mask	
278	Jog Mask	
279	Direction Mask	
280	Reference Mask	
281	Accel Mask	
282	Decel Mask	
283	Fault Clr Mask	
284	MOP Mask	
285	Local Mask	
298	DPI Ref Select	
299	DPI Fdbk Select	
300-307	Data In XX	
310-317	Data Out XX	
320	Anlg In Config	
321	Anlg In Sqr Root	
322, 325	Analog In X Hi	
323, 326	Analog In X Lo	
324, 327	Analog In X Loss	
340	Anlg Out Config	
341	Anlg Out Absolut	
342, 345	Analog OutX Sel	
343, 346	Analog OutX Hi	
344, 347	Analog OutX Lo	
354, 355	Anlg OutX Scale	
361-366	Digital InX Sel	
377, 378	Anlg OutX Setpt	
379	Dig Out Setpt	
380, 384, 388	Digital OutX Sel	
381, 385, 389	Dig OutX Level	
382, 386, 390	Dig OutX OnTime	
383, 387, 391	Dig OutX OffTime	
412	Motor Fdbk Type	
413	Encoder PPR	
416	Fdbk Filter Sel	
419	Notch Filter Freq	
420	Notch Filter K	
422	Pulse In Scale	

Number	Parameter Name	Setting
423	Encoder Z Chan	
427, 431	Torque Ref X Sel	
428, 432	Torque Ref X Hi	
429, 433	Torque Ref X Lo	
430	Torq Ref A Div	
434	Torque Ref B Mult	
435	Torque Setpoint	
436	Pos Torque Limit	
437	Neg Torque Limit	
438	Torque Setpoint2	
440	Control Status	
445	Ki Speed Loop	
446	Kp Speed Loop	
447	Kf Speed Loop	
449	Speed Desired BW	
450	Total Inertia	
454	Rev Speed Limit	
459	PI Deriv Time	
460	PI Reference Hi	
461	PI Reference Lo	
462	PI Feedback Hi	
463	PI Feedback Lo	
476-494	ScaleX In Value	
477-495	ScaleX In Hi	
478-496	ScaleX In Lo	
479-497	ScaleX Out Hi	
480-498	ScaleX Out Lo	
600	TorqProve Cnfg	
601	TorqProve Setup	
602	Spd Dev Band	
603	SpdBand Integrat	
604	Brk Release Time	
605	ZeroSpdFloatTime	
606	Float Tolerance	
607	Brk Set Time	
608	TorqLim SlewRate	
609	BrkSlip Count	
610	Brk Alarm Travel	
611	MicroPos Scale%	

Rockwell Automation Support

Rockwell Automation provides technical information on the Web to assist you in using its products.

At <http://www.rockwellautomation.com/support>, you can find technical manuals, technical and application notes, sample code and links to software service packs, and a MySupport feature that you can customize to make the best use of these tools. You can also visit our Knowledgebase at <http://www.rockwellautomation.com/knowledgebase> for FAQs, technical information, support chat and forums, software updates, and to sign up for product notification updates.

For an additional level of technical phone support for installation, configuration and troubleshooting, we offer TechConnectSM support programs. For more information, contact your local distributor or Rockwell Automation representative, or visit <http://www.rockwellautomation.com/support/>.

Installation Assistance

If you experience a problem within the first 24 hours of installation, please review the information that's contained in this manual. You can also contact a special Customer Support number for initial help in getting your product up and running.

United States or Canada	1.440.646.3434
Outside United States or Canada	Use the Worldwide Locator at http://www.rockwellautomation.com/rockwellautomation/support/overview.page , or contact your local Rockwell Automation representative.

New Product Satisfaction Return

Rockwell Automation tests all of its products to help ensure that they are fully operational when shipped from the manufacturing facility. However, if your product is not functioning and needs to be returned, follow these procedures.

United States	Contact your distributor. You must provide a Customer Support case number (call the phone number above to obtain one) to your distributor to complete the return process.
Outside United States	Please contact your local Rockwell Automation representative for the return procedure.

Documentation Feedback

Your comments will help us serve your documentation needs better. If you have any suggestions on how to improve this document, complete this form, publication [RA-DU002](#), available at <http://www.rockwellautomation.com/literature/>.

Rockwell Otomasyon Ticaret A.Ş., Kar Plaza İş Merkezi E Blok Kat:6 34752 İçerenköy, İstanbul, Tel: +90 (216) 5698400

www.rockwellautomation.com

Power, Control and Information Solutions Headquarters

Americas: Rockwell Automation, 1201 South Second Street, Milwaukee, WI 53204-2496 USA, Tel: (1) 414.382.2000, Fax: (1) 414.382.4444

Europe/Middle East/Africa: Rockwell Automation NV, Pegasus Park, De Kleerlaan 12a, 1831 Diegem, Belgium, Tel: (32) 2 663 0600, Fax: (32) 2 663 0640

Asia Pacific: Rockwell Automation, Level 14, Core F, Cyberport 3, 100 Cyberport Road, Hong Kong, Tel: (852) 2887 4788, Fax: (852) 2508 1846

Publication 20B-UM001H-EN-P - June 2013

Supersedes Publication 20B-UM001G-EN-P - August 2004

Copyright © 2013 Rockwell Automation, Inc. All rights reserved. Printed in the U.S.A.