

# PowerFlex 700 Drive - Frame 8 Components Replacement

Catalog Numbers 20B



## Important User Information

Read this document and the documents listed in the additional resources section about installation, configuration, and operation of this equipment before you install, configure, operate, or maintain this product. Users are required to familiarize themselves with installation and wiring instructions in addition to requirements of all applicable codes, laws, and standards.

Activities including installation, adjustments, putting into service, use, assembly, disassembly, and maintenance are required to be carried out by suitably trained personnel in accordance with applicable code of practice.

If this equipment is used in a manner not specified by the manufacturer, the protection provided by the equipment may be impaired.

In no event will Rockwell Automation, Inc. be responsible or liable for indirect or consequential damages resulting from the use or application of this equipment.

The examples and diagrams in this manual are included solely for illustrative purposes. Because of the many variables and requirements associated with any particular installation, Rockwell Automation, Inc. cannot assume responsibility or liability for actual use based on the examples and diagrams.

No patent liability is assumed by Rockwell Automation, Inc. with respect to use of information, circuits, equipment, or software described in this manual.

Reproduction of the contents of this manual, in whole or in part, without written permission of Rockwell Automation, Inc., is prohibited.

Throughout this manual, when necessary, we use notes to make you aware of safety considerations.



**WARNING:** Identifies information about practices or circumstances that can cause an explosion in a hazardous environment, which may lead to personal injury or death, property damage, or economic loss.



**ATTENTION:** Identifies information about practices or circumstances that can lead to personal injury or death, property damage, or economic loss. Attentions help you identify a hazard, avoid a hazard, and recognize the consequence.

---

### IMPORTANT

Identifies information that is critical for successful application and understanding of the product.

---

Labels may also be on or inside the equipment to provide specific precautions.



**SHOCK HAZARD:** Labels may be on or inside the equipment, for example, a drive or motor, to alert people that dangerous voltage may be present.



**BURN HAZARD:** Labels may be on or inside the equipment, for example, a drive or motor, to alert people that surfaces may reach dangerous temperatures.



**ARC FLASH HAZARD:** Labels may be on or inside the equipment, for example, a motor control center, to alert people to potential Arc Flash. Arc Flash will cause severe injury or death. Wear proper Personal Protective Equipment (PPE). Follow ALL Regulatory requirements for safe work practices and for Personal Protective Equipment (PPE).

---

### New and Updated Information

This table contains the changes made to this revision.

Topic	Page
Updated the Component Kits table with the new balancing resistor kit catalog numbers.	<a href="#">9</a>
Updated <a href="#">Figure 3</a> - Frame 8 Busbars (AC Drive shown) to include the new balancing resistor bus bar assembly.	<a href="#">17</a>
Updated the Balancing Resistor and DC+ Bus Bar instructions for removing and installing the new kit.	<a href="#">48</a>
Moved the summary of changes information for the previous revision to Appendix A - History of Changes.	<a href="#">83</a>

**Notes:**

<b>Preface</b>	Introduction.....	9
	Component Kits.....	9
	Recommended Tools.....	11
	Additional Resources.....	11
	Safety Precautions.....	12
	Important Initial Steps.....	13
	<b>Chapter 1</b>	
<b>Component Diagrams and Torque Specifications</b>	Drive Components.....	15
	Circuit Boards.....	19
	Fastener Torque Specifications.....	20
	Torque Sequence.....	20
	Torque Specifications.....	21
	<b>Chapter 2</b>	
<b>Basic Component Removal Procedures</b>	Overview.....	23
	Main Control Panel.....	24
	Remove Components.....	24
	Install Components.....	25
	Stacking Panel.....	26
	Remove Components.....	26
	Install Components.....	27
	Transitional Busbar Assembly.....	28
	Remove Components.....	28
	Install Components.....	32
	<b>Chapter 3</b>	
<b>Component Replacement Procedures</b>	Overview.....	35
	Main Control Board.....	35
	Remove Components.....	35
	Install Components.....	36
	T-Comm Board.....	37
	Remove Components.....	37
	Install Components.....	39
	Power Interface Board.....	40
	Remove Components.....	40
	Install Components.....	41
	Switch Mode Power Supply Board.....	42
	Remove Components.....	42
	Install Components.....	42
	Precharge Board.....	43
	Remove Components.....	43
	Install Components.....	43
	DC Bus Filter Board.....	44

Remove Components.....	44
Install Components.....	44
Bus Capacitor.....	45
Remove Components.....	45
Install Components.....	46
Capacitor Bank Fan .....	47
Remove Components.....	47
Install Components.....	47
Balancing Resistor and DC+ Bus Bar .....	48
Remove Components.....	48
Install Components.....	54
Inverter Power Module (IGBT) .....	58
Remove Components.....	58
Install Components.....	60
Gate Interface Board.....	62
Remove Components.....	62
Install Components.....	62
Current Transducer .....	63
Remove Components.....	63
Install Components.....	64
Converter Power Module - (SCR) AC Input Only .....	65
Remove Components.....	65
Install Components.....	66
Converter Snubber Resistors - AC Input Only.....	67
Remove Components.....	67
Install Components.....	68
Converter Snubber Board - AC Input Only.....	68
Remove Components.....	68
Install Components.....	69
Fan Transformer .....	69
Remove Components.....	69
Install Components.....	69
Heatsink Fan - Removal from Back of Drive .....	70
Remove Components.....	70
Install Components.....	71
Heatsink Fan - Removal from Front of Drive .....	72
Remove Components.....	72
Install Components.....	76
Thermal Sensors .....	77
Remove Components.....	78
Install Components.....	78
DC Link Choke - AC Input Only .....	79
Remove Components.....	79
Install Components.....	79
MOV Surge Suppressor - AC Input Only.....	80
Remove Components.....	80
Install Components.....	80

Precharge SCR Module and Diode - DC Input Only..... 81  
    Remove Components..... 81  
    Install Components ..... 81

**Appendix A**

**History of Changes**

20B-IN024C-EN-P, June 2012 ..... 83





## Introduction

This publication provides guidelines for replacing the major components in the PowerFlex® 700 Frame 8 drive.

## Component Kits

All kits include the necessary components, ESD wrist strap and hardware (if required), and thermal grease (if required). Do not reuse any hardware unless directed to do so.

Description	Kit Catalog No.	Notes
<b>Printed Circuit Boards</b>		
Gate Interface Board	SK-G1-GDB1-F8910	Drive requires three kits
Precharge Board	SK-G9-PRE1-V480	AC input
	1336-PB-SP22C	DC input
Power Interface Board	SK-G9-GDB1-D365	365A drives
	SK-G9-GDB1-D415	415A drives
	SK-G9-GDB1-D481	481A drives
	SK-G9-GDB1-D535	535A drives
	SK-G9-GDB1-D600	600A drives
Main Control Board	SK-G9-VMCB1-D0	115V I/O
	SK-G9-VMCB1-C0	24V I/O
T-Comm Board	SK-G9-TCOMM	
Switch Mode Power Supply Board	SK-G9-PWRS1-D0	
DC Bus Filter Board	2364-SPP02A	
<b>Fans and Main Fan Circuit Components</b>		
Heatsink Fan	SK-G1-FAN1-F810	Includes fan and fan enclosure.
Capacitor Fan	SK-G1-FAN2-F8910	
<b>Power Module Sub-assemblies</b>		
Inverter Power Module (IGBT)	SK-G1-QOUT1-F8	Includes: <ul style="list-style-type: none"> <li>• One IGBT module</li> <li>• One gate interface board</li> <li>• Gate interconnect harness</li> <li>• Six flexible capacitor busbars</li> <li>• Three snubber capacitors</li> <li>• One tie down capacitor mount</li> </ul> Drive requires three kits.
Converter Power Module (SCR)	SK-G1-SCR1-F89	AC input. Kit includes three SCR modules.
SCR Snubber Kit	SK-G1-SCRSNUBRB	AC input drive requires three kits.
DC Precharge SCR Module	SK-G1-SCR2-F89	DC input. Includes: <ul style="list-style-type: none"> <li>• One SCR module</li> <li>• One diode</li> </ul>
<b>Miscellaneous</b>		
Current Transducer	SK-G1-CT1-F8	Includes one transducer. Drive requires three kits.

Description	Kit Catalog No.	Notes
Thermal Sensor Kit	SK-G1-THM1-F89	AC input. Includes: • Main control panel thermal sensor • Heatsink thermal sensor
	SK-G1-THM2-F89	DC input. Includes: • Main control panel thermal sensor • Heatsink thermal sensor
<b>Miscellaneous</b> (continued)		
Bus Capacitor Kit	SK-G1-BUSCAP1-F8	365A, 415A and 481A only. Includes one capacitor. Drive requires 18 kits.
	SK-G1-BUSCAP2-F8	535A and 600A only. Includes one capacitor. Drive requires 18 kits.
Capacitor Bus Finger Kit	SK-G1-FLXBUS1	Included with the kit for inverter power module (IGBT). Can be ordered separately. Includes: • Three positive flexible capacitor busbars • Three negative flexible capacitor busbars
MOV Surge Suppressor	SK-G1-MOV1-F89	AC input.
Power Supply, 24V	SK-G9-PWRS24	
DC Link Choke	SK-G1-DCCHOKE1-F8	AC input.
Transformer, 500 VA	SK-G9-XFMR1-F89	AC input. Includes • One transformer • Three fuses
Transformer Fuses	SK-G9-FUSE1-F8	AC input. Includes three fuses.
Balancing Resistor Kit	SK-G1-RB1-F8 (Replaces 1336-RLOAD-SP3A) <sup>(1)</sup>	AC Input (includes DC+ bus bar and resistor assembly).
	SK-G1-CBRB1-F8 (Replaces 1336-RLOAD-SP3A) <sup>(1)</sup>	DC Input (includes DC+ bus bar and resistor assembly).

(1) This kits was issued to correct a potential anomaly for frame 8 PowerFlex 700 AC drives. See Product Safety Advisory #2014-06-002 for more information.

Refer to the master parts list for the most recent information:

<http://www.ab.com/support/abdrives/powerflex70/PF7ReleasedParts.pdf>

**IMPORTANT**

Refer to the instruction sheet included with each component kit for instructions regarding discarding or returning replaced components. If discarding, be sure to discard according to local, state, and federal regulations.

## Recommended Tools

The following list includes the most common tools used to disassemble and assemble the drive and components. This list may not include all the tools for your situation. Not all tools are needed for some components. Refer to the specific sections for details.

Description
Torque wrench (metered in N•m or lb•in)
Volt ohm meter
Torque seal or colored marker
Screwdrivers (standard, Phillips, torx — various sizes)
Magnetic screwdriver, long
Socket set, metric
Cylindrical pick-up magnet
Pliers, regular and needle-nose
Wire cutters
Isopropyl alcohol and applicator cloth
Nylon tie wraps
3- or 4-inch paint roller with short nap or 3- or 4-inch putty knife (for installing SCR modules)
Pencil

## Additional Resources

These documents contain additional information concerning related products from Rockwell Automation.

Resource	Description
PowerFlex 700 Adjustable Frequency AC Drive Frames 7...10 Installation Instructions, publication <a href="#">20B-IN014</a>	Provides basic information needed to mount, wire, and start-up a PowerFlex 700 drive.
PowerFlex 700 AC Drives User Manual, publication <a href="#">20B-UM002</a>	Provides basic information needed to install, start-up and troubleshoot the PowerFlex 700 drive.
Industrial Automation Wiring and Grounding Guidelines, publication <a href="#">1770-4.1</a>	Provides general guidelines for installing a Rockwell Automation industrial system.
Product Certifications website, <a href="http://www.ab.com">http://www.ab.com</a>	Provides declarations of conformity, certificates, and other certification details.

You can view or download publications at <http://www.rockwellautomation.com/literature/>. To order paper copies of technical documentation, contact your local Allen-Bradley® distributor or Rockwell Automation sales representative.

## Safety Precautions

The precautions and general installation requirements provided in the PowerFlex 700 Frame 7...10 Installation Instructions (publication [20B-IN014](#)) and the PowerFlex 700 User Manual (publication [20B-UM002](#)) must be followed in addition to those included here.



**ATTENTION:** To avoid an electric shock hazard, ensure that all power has been removed before proceeding. In addition, before servicing, verify that the voltage on the bus capacitors has discharged. Check the DC bus voltage at the Power Terminals by measuring between the +DC & DC- terminals, between the +DC terminal and the chassis, and between the DC- terminal and the chassis. The voltage must be zero for all three measurements.

Remove power before making or breaking cable connections. When you remove or insert a cable connector with power applied, an electrical arc may occur. An electrical arc can cause personal injury or property damage by:

- sending an erroneous signal to your system's field devices, causing unintended machine motion.
- causing an explosion in a hazardous environment.

Electrical arcing causes excessive wear to contacts on both the module and its mating connector. Worn contacts may create electrical resistance.

1. Turn off and lock out input power. Wait five minutes.
2. Verify that there is no voltage at the drive's input power terminals.
3. Check the DC bus voltage at the power terminals by measuring between the +DC and -DC terminals, between the +DC terminal and the chassis, and between the -DC terminal and the chassis. The voltage must be zero for all three measurements.

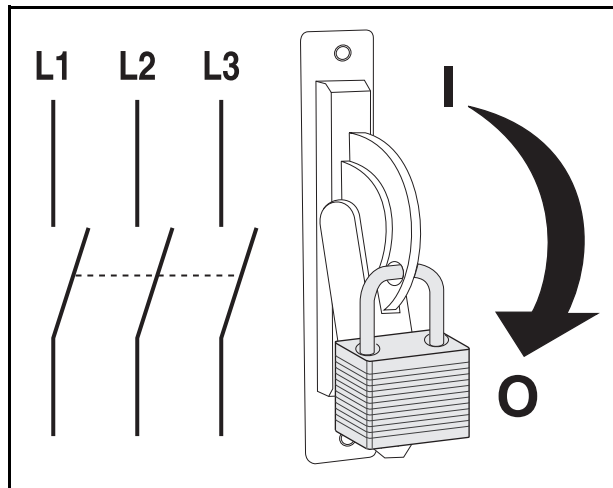



**ATTENTION:** This assembly contains parts and sub-assemblies that are sensitive to electrostatic discharge. Static control precautions are required when servicing this assembly. Component damage may result if you ignore electrostatic discharge control procedures. If you are not familiar with static control procedures, refer to Guarding Against Electrostatic Damage, Allen-Bradley publication [8000-4.5.2](#), or any other applicable ESD protection handbook.

The information in this publication is merely a guide for proper installation. Rockwell Automation, Inc. cannot assume responsibility for the compliance or the noncompliance to any code (national, local, or otherwise) for the proper installation of this drive or associated equipment. A hazard of personal injury and/or equipment damage exists if codes are ignored.

Only qualified personnel familiar with adjustable frequency AC drives and associated machinery should plan or implement the installation, start-up, and subsequent maintenance of the system. Failure to comply may result in personal injury and/or equipment damage.

Hot surfaces can cause severe burns. **Do not** touch the heatsink surface during operation of the drive. After disconnecting power, allow time for cooling.

Replace all protective shields before applying power to the drive. Failure to replace protective shields may result in death or serious injury.

---

## Important Initial Steps

Read and follow these statements before performing any service on the drive.

- Read and follow the precautions in [Safety Precautions on page 12](#).
- Identify components to be replaced using the figures in [Chapter 1](#).
- Remove protective shields only as necessary.
- Before disconnecting any wire or cable, verify that it is labeled. Also, when removing components, note hardware type and location.
- When torquing any fasteners, use a colored marker or torque seal to mark each screw after torquing so you know when all are done and to indicate signs of any subsequent tampering.
- Refer to the product installation documentation for startup and other instructions after servicing.

**Notes:**

# Component Diagrams and Torque Specifications

## Drive Components

Figure 1 - Frame 8 AC Drive Components

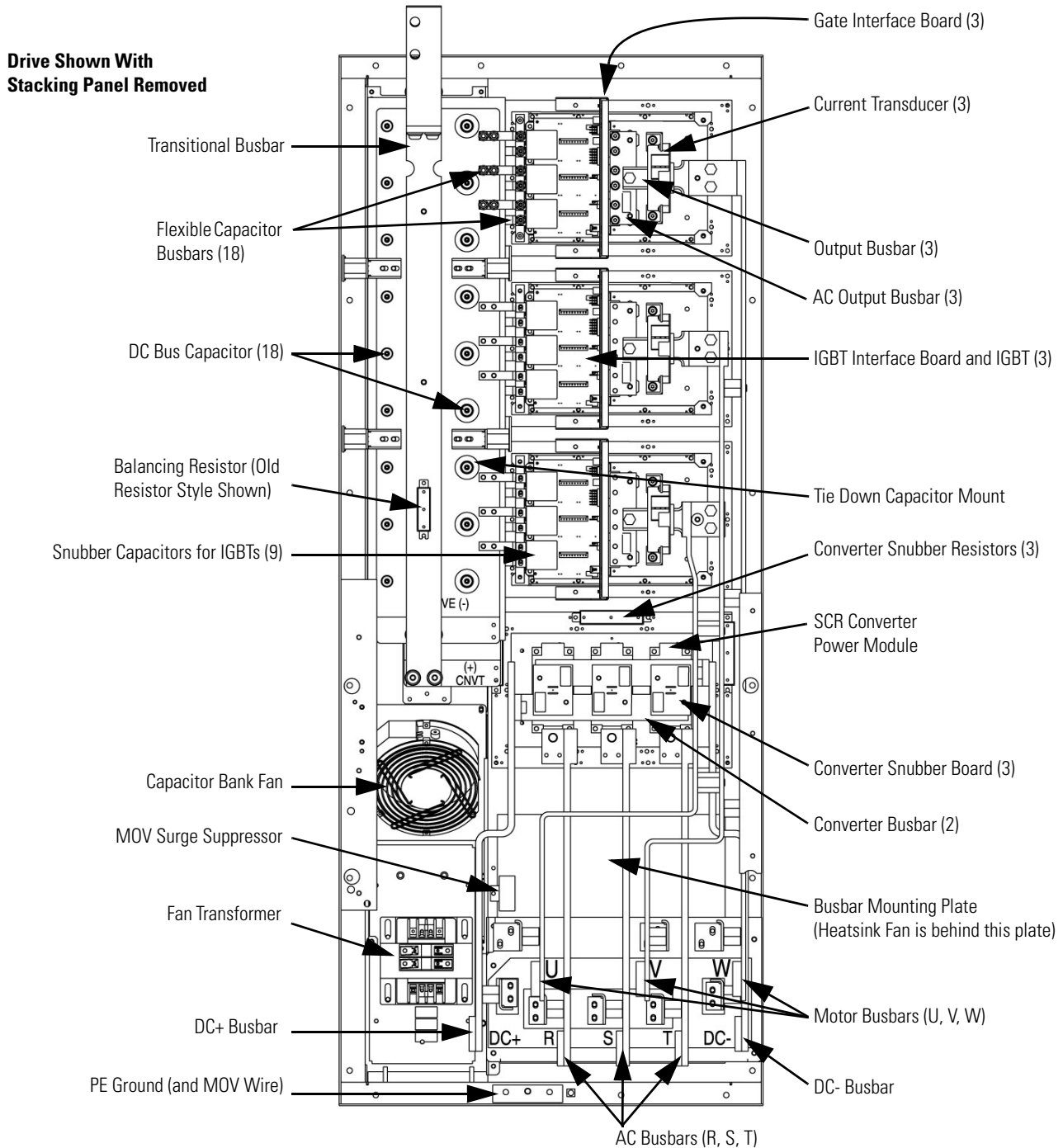

Figure 2 - Frame 8 DC Drive Components

Drive Shown With Stacking Panel Removed

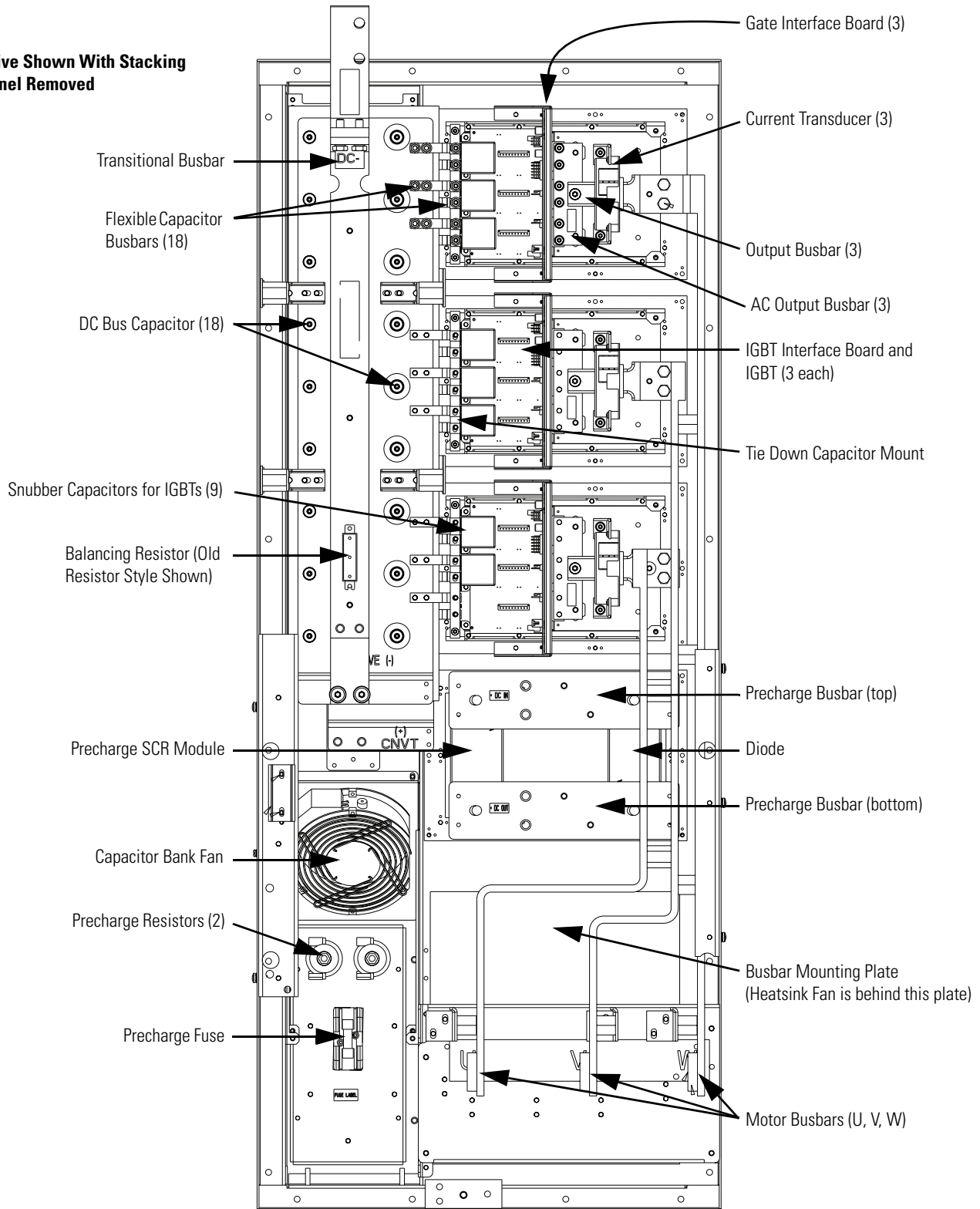



Figure 3 - Frame 8 Busbars (AC Drive shown)

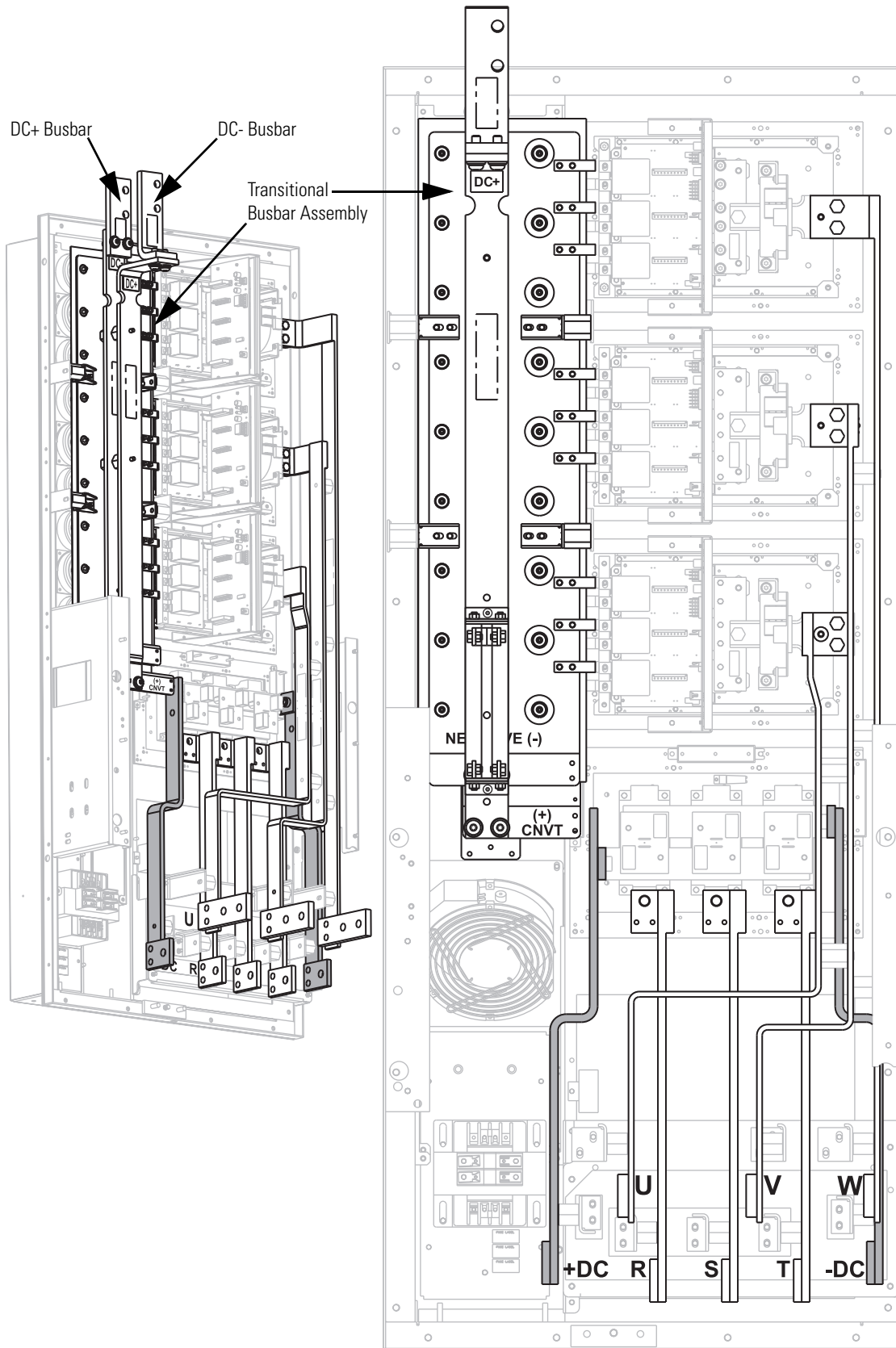
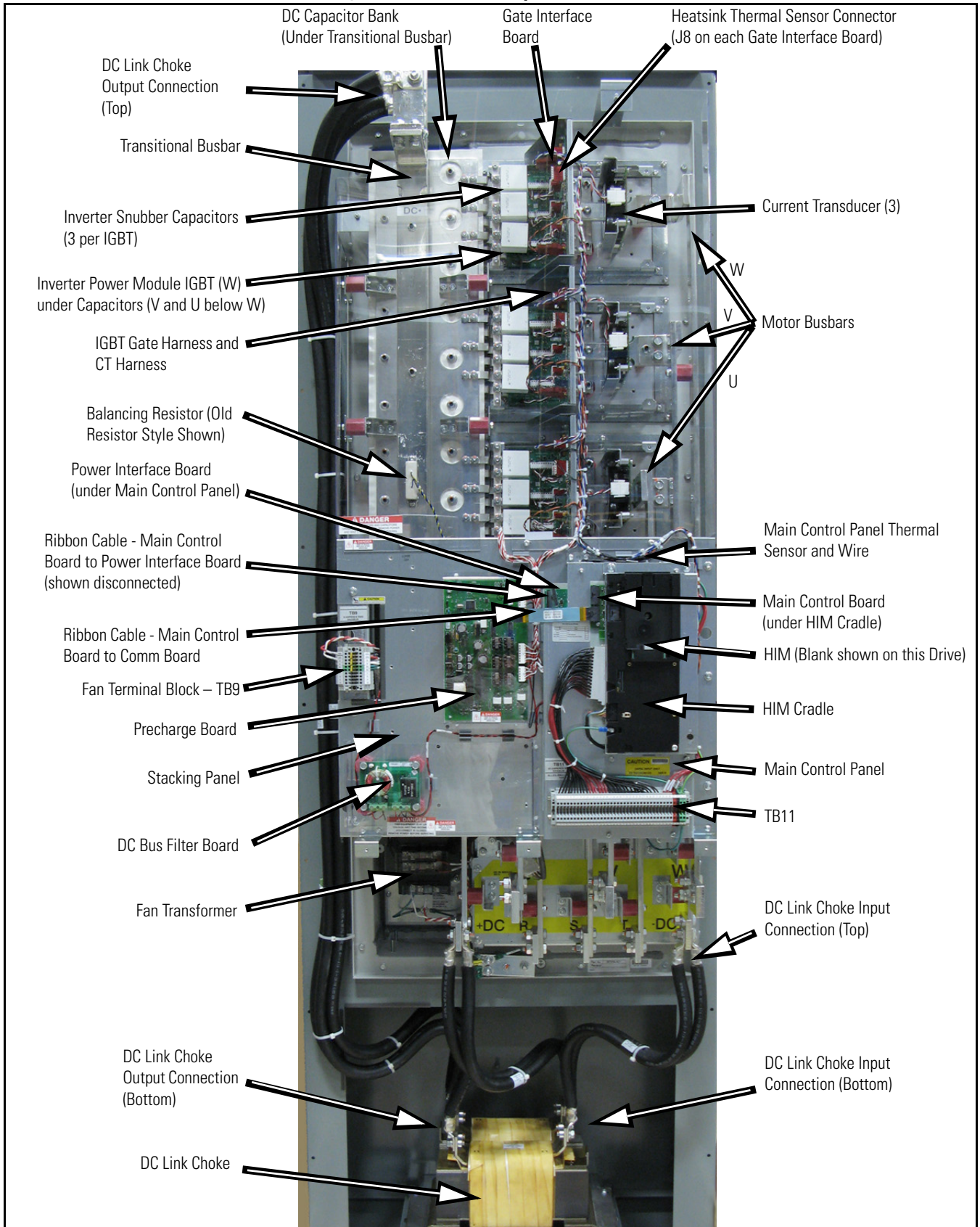
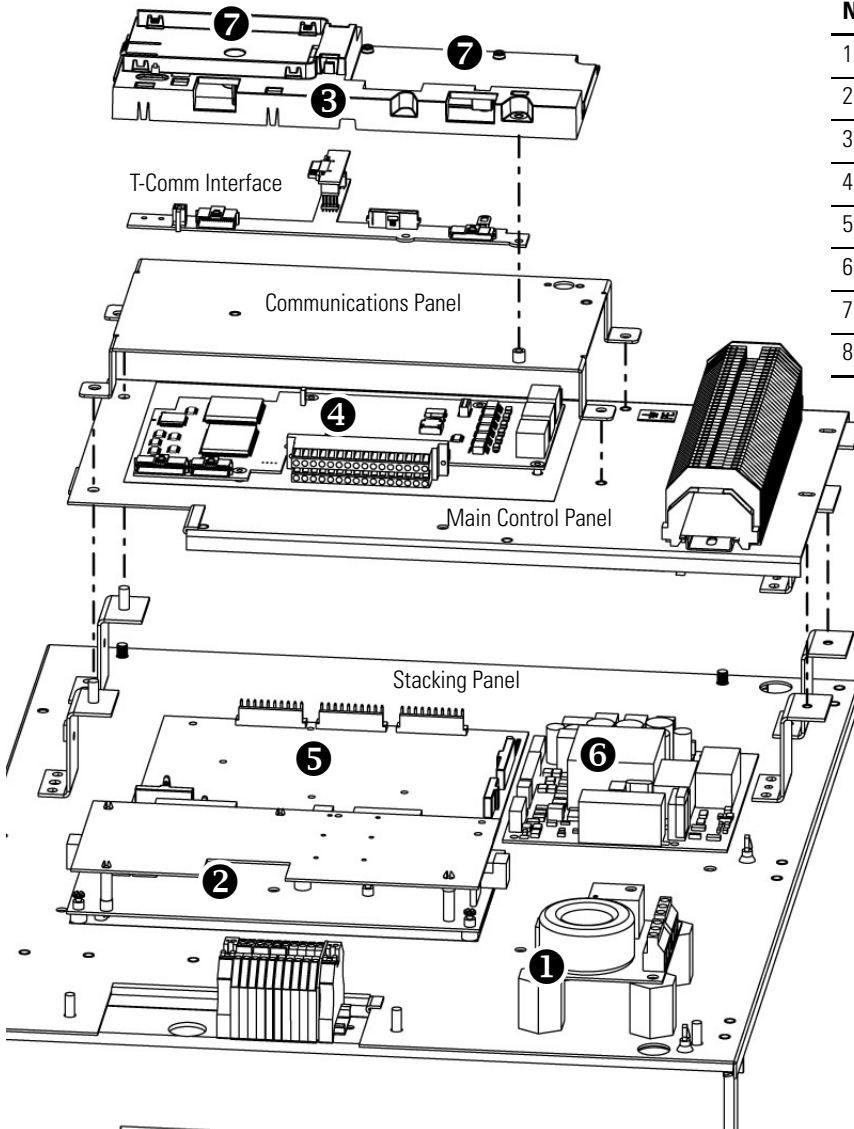
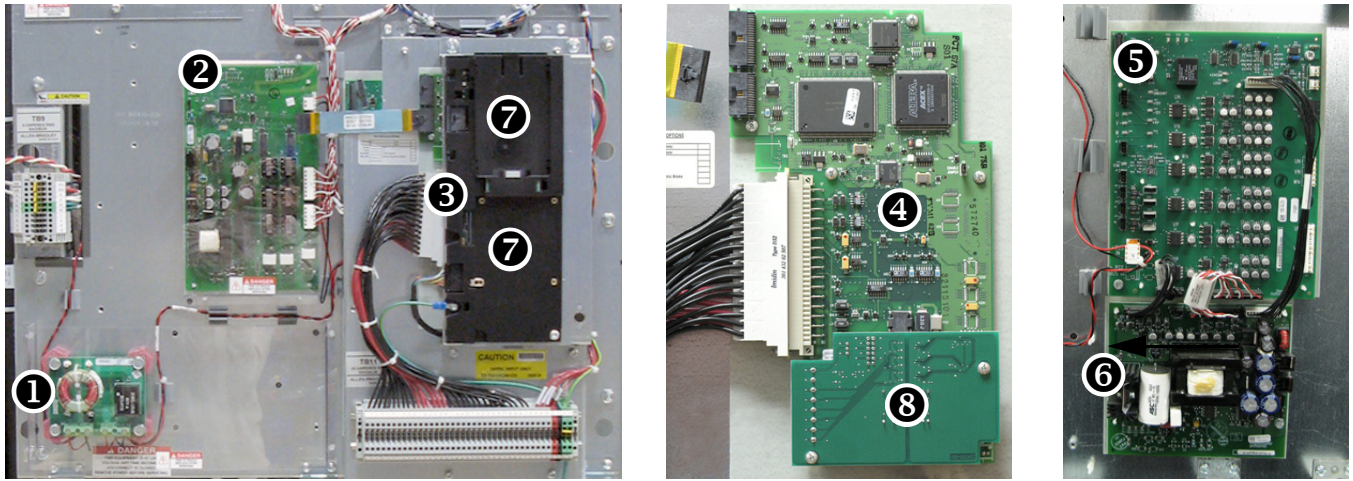

Figure 4 - Frame 8 (AC input drive shown)



## Circuit Boards

**Figure 5 - Circuit Boards on Frame 8**



No.	Description
1	DC bus filter board
2	Precharge board
3	HIM cradle/board
4	Main control board
5	Power interface board
6	Switch mode power supply board
7	Communication board slots (optional)
8	Encoder board (optional)

## Fastener Torque Specifications

### Torque Sequence



**ATTENTION:** When mounting components to a drive's heatsink, component fastener torque sequences and tolerances are crucial to component-to-heatsink heat dissipation.

Components can be damaged if initial tightening procedure is not performed to specification.

The following illustrates initial and final tightening sequences for components fastened to a heatsink using two, four, and six screws. Initial torque is 1/3 (33%) of final torque, except six-point mountings, which require 0.7 N•m (6 lb•in.) The numeric illustration labels are for your assistance. Drive components do not carry these labels.

Figure 6 - Various-point Mounting

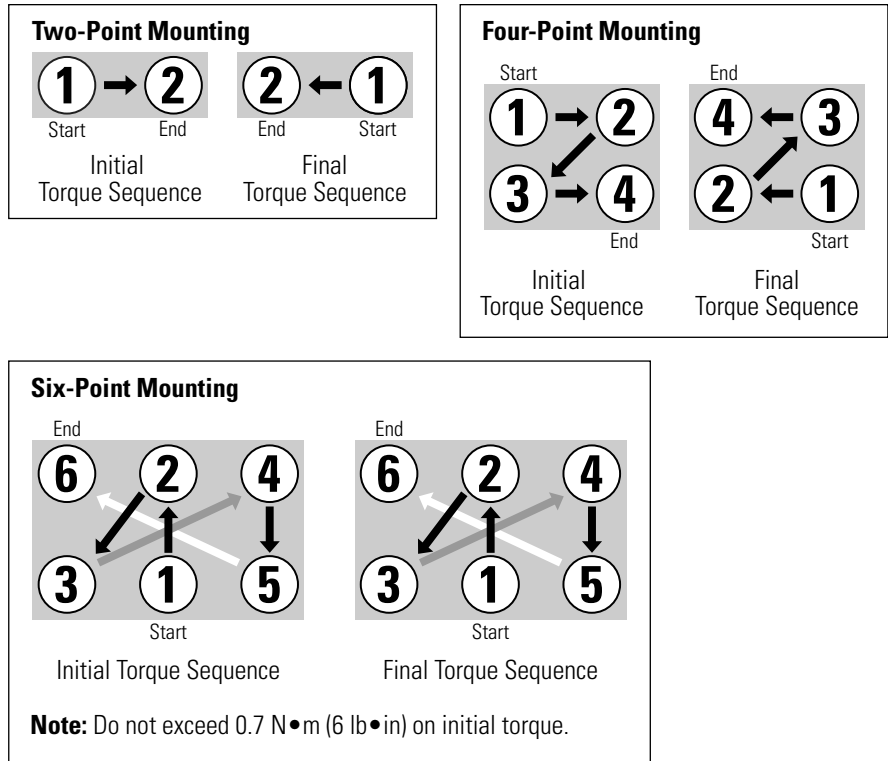

## Torque Specifications

The following table lists fastener locations by component, how the fasteners are used, and torque specifications. Refer to [Torque Sequence](#) in this chapter for fastening two-point, four-point, and six-point components to the heatsink.

Component	Fastener Application	Torque	
		N•m	lb•in
20-Comm-x board	fasten to HIM cradle/board	2.9	26
AC busbars (R, S, and T)	fasten to converter SCR module	9	80
AC output busbar	fasten to standoffs on heatsink	5.6	50
	fasten to IGBT	5.6	50
Balancing resistor	fasten to the transitional busbar	2.9	26
Balancing resistor wires	black: negative (-) busbar	2.9	26
	yellow: bus capacitor busbar	2.9	26
	blue: converter (+) busbar	2.9	26
Busbars (DC+ and DC-)	fasten upper busbar mounts to the converter busbars	23.5	208
Busbar mounting plate	fasten the busbars to the bottom of the chassis	6	50
Busbar mounting plate bracket (left)	fasten to the left side of the converter busbar	6	50
Bus capacitor busbar	fasten to the capacitor setscrews (short)	5.6	50
Cables	fasten +DC IN and +DC OUT cables to the transitional busbar	23.5	208
Capacitor bank fan	fasten to chassis below the capacitor bank	1.8	16
Capacitor setscrews	short setscrew fastens capacitor to the bus capacitor busbar	0.7	6
	long setscrew fastens capacitor to the transitional busbar	0.7	6
Communications panel	fasten to the main control panel top of the communications panel	5.6	50
	bottom of the communications panel	2.9	26
Converter busbars	fasten to converter SCR modules	9	80
Converter power modules (SCR) – AC input only	fasten to heatsink: first sequence	0.7	6
	final sequence	5.6	50
Converter SCR modules wiring	fasten to the busbar connection at the SCR module	2.9	26
Converter snubber board – AC input only	fasten to the standoffs on the converter busbars	2.9	26
Converter snubber resistors – AC input only	fasten to the frame around the heatsink	2.9	26
Current transducer brackets	fasten the mounting brackets to the current transducer	1.6	14
Current transducer assembly	fasten to the backplane	2.9	26
DC bus filter board	fasten to glastic standoffs on stacking panel	1.7	15
DC link choke – AC input only	fasten mounting brackets to the bottom of the chassis	9	80
	fasten cables to the choke connectors	9	80
Encoder board (optional)	fasten to standoffs on main control board	2	14
Heatsink fan cover	fasten to the back of the drive	2.9	26
Heatsink fan mounting plate	fasten the heatsink fan to the fan mounting plate	2.9	26
Fan transformer	fasten to the mounting plate below the capacitor bank fan	5.6	50

Component	Fastener Application	Torque	
		N•m	lb•in
Flexible capacitor busbars	fasten to the transitional busbar	5.6	50
	fasten to the IGBT module	5.6	50
Gate interface board	fasten to upright bracket on heatsink	1.8	16
Ground wire (green and yellow)	from TB11 to the HIM cradle/board	1.6	14
HIM cradle/board	fasten to the main control panel	2.9	26
IGBT module	fasten to the heatsink:		
	first sequence	0.7	6.0
	second sequence	2.3	20
	final sequence	5.6	50
Main control board	fasten to the main control panel	2	14
Main control panel	fasten to the stacking panel:		
	top of the main control panel	5.6	50
	bottom of the main control panel	2.9	26
MOV surge suppressor – AC input only	fasten to the chassis	2.9	26
MOV surge suppressor – AC input only (wiring)	fasten black wires to R, S, and T busbar connection at the SCR modules	2.9	26
	fasten green and yellow ground wire to ground stud at the bottom of the chassis	9.0	80
Output busbar	fasten to the AC output busbar	9.0	80
	fasten to the U, V, or W busbar	9.0	80
	setscrew and nut to the U, V, or W busbar	5.6	50
Power interface board	fasten to stacking panel	1.7	15
Precharge board	fasten to stacking panel		
	for AC input	1.7	15
	for DC input (1/4 turn clockwise)	–	–
Precharge SCR module and diode – DC input only	fasten to the heatsink:		
	first sequence	0.7	6.0
	final sequence	5.6	50
Precharge busbars – DC input only	fasten to the SCR module and diode	5.6	50
Precharge wires – DC input only	fasten to the precharge busbars	2.9	26
Precharge power cables – DC input only	fasten to the precharge busbars	12.2	108
Snubber resistors	fasten to the IGBT setscrews at the tie down capacitor mount	5.6	50
Stacking panel	fasten to the chassis	5.6	50
Switch mode power supply board	fasten to stacking panel	1.7	15
Thermal sensors	fasten to heatsink		hand tighten
	fasten to main control panel		hand tighten
Tie down capacitor mount	fasten to the bracket at left of IGBT board	5.6	26
Transitional busbar	mounting brackets to the glastic spacers	5.6	50
	mounting brackets to the drive	2.9	26
	fasten to the bus capacitor setscrews	5.6	50

## Basic Component Removal Procedures

### Overview

Component removal and replacement in this chapter are located on the stacking panel and transitional busbar assemblies highlighted below.

See Circuit Boards on page 19 to identify the various panels that comprise the stacking panel assembly.

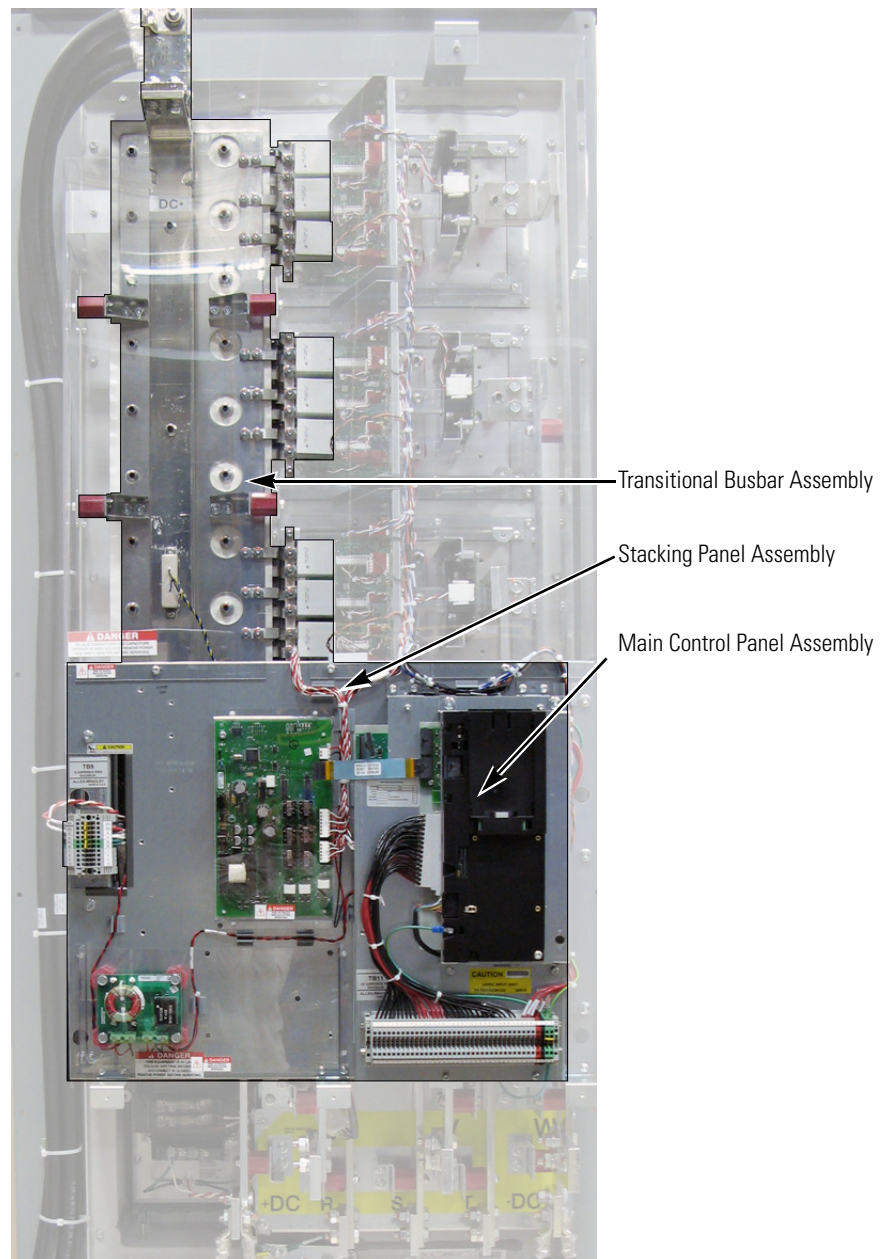

## Main Control Panel

See Chapter 1 - Component Diagrams and Torque Specifications on page 15 to locate the component detailed in these instructions.

### Remove Components

1. Read and follow the Safety Precautions on page 12 and Important Initial Steps on page 13.
2. Remove the ribbon cable going from the main control board (J2) to the power interface board (J1).

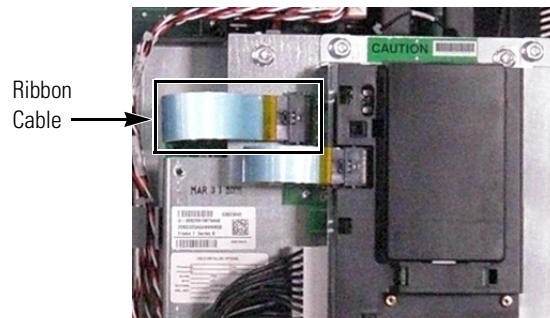

3. Disconnect the incoming ground wire to TB11.
4. Remove the two screws on the main control panel below TB11.
5. Remove the two mounting nuts at the top of the main control panel.

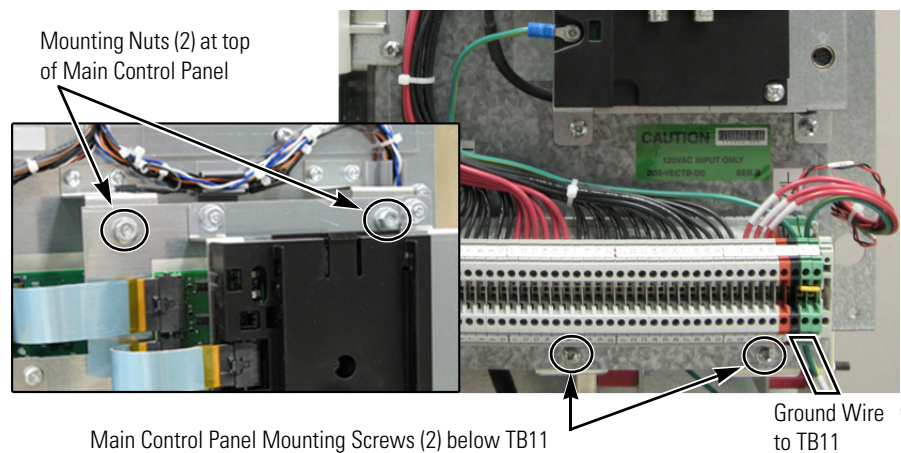

6. Disconnect the wire harnesses from TB11 to the switch mode power supply board (J4 connector) and at TB1 and TB2 on the power interface board.
7. Label and remove all customer wiring from TB11.
8. Remove the main control panel and carefully set aside.



## Install Components

1. Replace any customer wiring to TB11.
2. Connect the wire harnesses from TB11 to the switch mode power supply board (J4 connector) and at TB1 and TB2 on the power interface board.
3. Torque the two mounting nuts at the top of the main control panel to 5.6 N•m (50 lb•in).
4. Torque the two screws on the main control panel below TB11 to 2.9 N•m (26 lb•in).
5. Connect the incoming ground wire to TB11.
6. Connect the ribbon cable going from the main control board (J2) to the power interface board (J1).
7. Replace all safety shields and enclosure covers before applying power to the drive.

## Stacking Panel

See Chapter 1 - Component Diagrams and Torque Specifications on page 15 to locate the component detailed in these instructions.

### Remove Components

1. Read and follow the Safety Precautions on page 12 and Important Initial Steps on page 13.
2. Label and disconnect wiring as listed below.

Shown without main control panel.

**NOTE:** Mounting position of boards on stacking panel may vary.

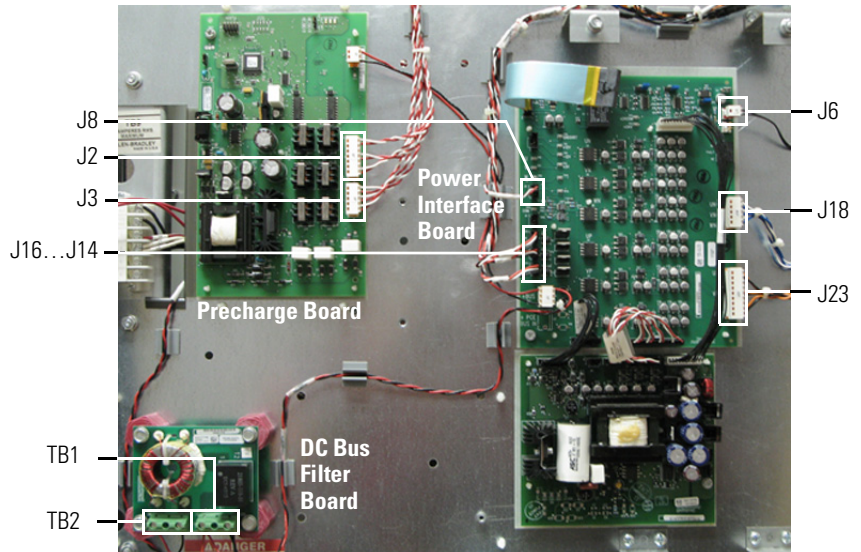

**TIP**

Remove the main control panel first to provide better access to wiring and fasteners. See Main Control Panel on page 24.

Connected Component	Label on Wire or Connector	Label on Board	Notes
Precharge board	J2, J3	J2, J3	
DC bus filter board	TB1	TB1	
Power interface board	J8	J8	
	J16	U	U phase CT
	J15	V	V phase CT
	J14	W	W phase CT
	J23	UP, VP, WP	U, V, W positive gates
	J18	UN, VN, WN	U, V, W negative gates
TB11	Customer wiring		Remove if not already done

3. Disconnect the main control panel thermal sensor and wire located above the main control board, from the wiring harness (see Figure 4 on page 18).

4. Remove the six nuts for mounting the stacking panel.

**Shown without main control panel.**

**NOTE: Mounting position of boards on stacking panel may vary.**

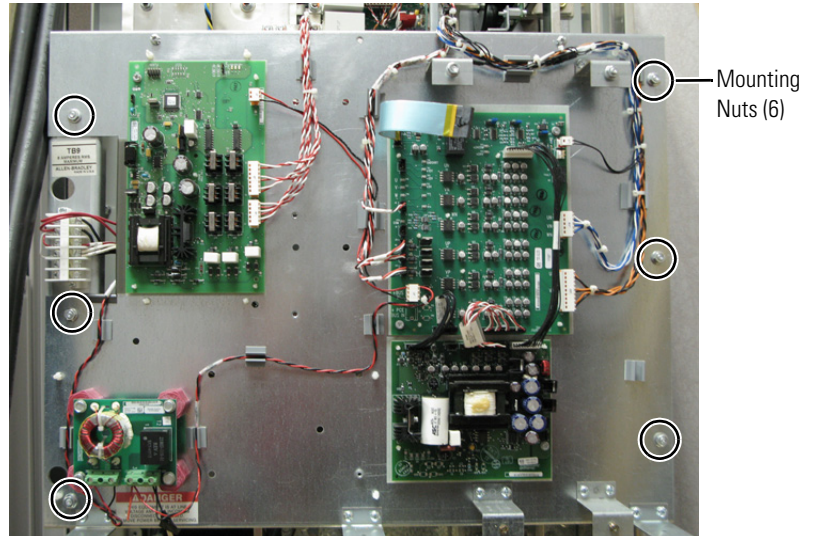

5. Remove the stacking panel; carefully set aside.

## Install Components

1. Torque the six mounting nuts to 5.6 N•m (50 lb•in).
2. Connect the main control panel thermal sensor and wire located above the main control board.
3. Connect all wiring that was removed.
4. Replace all safety shields and enclosure covers before applying power to the drive.

## Transitional Busbar Assembly

See Chapter 1 - Component Diagrams and Torque Specifications on page 15 to locate the component detailed in these instructions.

### Remove Components

1. Read and follow the Safety Precautions on page 12 and Important Initial Steps on page 13.
2. Remove the stacking panel as detailed on page 26.

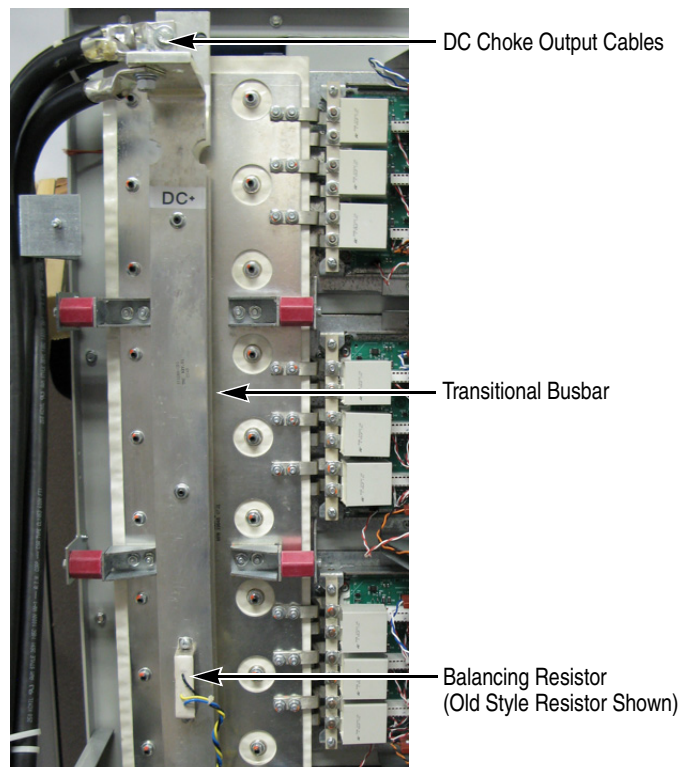

3. If present, remove all customer wiring to transitional busbar.
4. For AC input drives, remove the DC choke output cables.  
For DC input drives, there is no choke.
5. If present, disconnect the +DC IN and +DC OUT cables from the transitional busbar.

**6. Remove all IGBT Snubber components:**

- a. Remove the six nuts that secure each set of snubber capacitors. Remove the capacitors, and save nuts and capacitors.

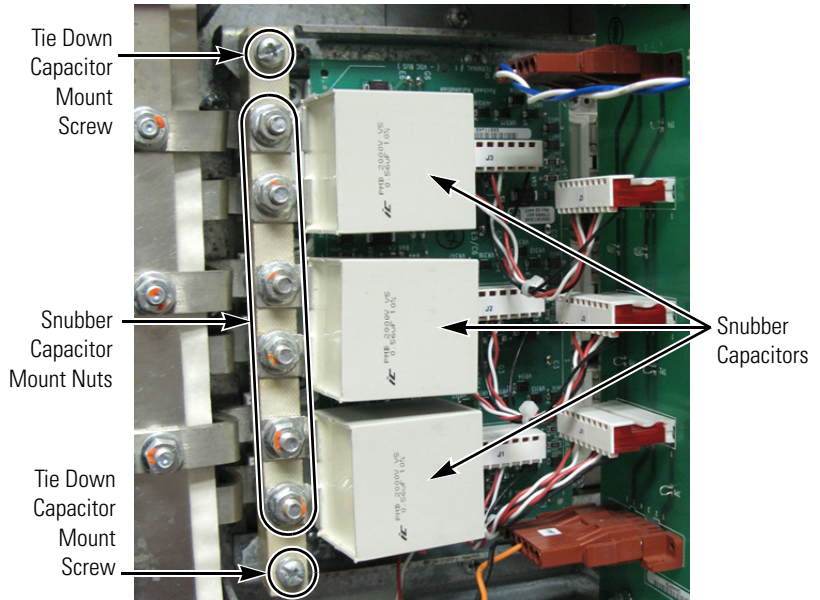

- b. Remove the two screws that secure each tie down capacitor mount. Remove the tie down capacitor mounts and save screws and capacitor mounts.
- c. Remove the six setscrews from each IGBT and save.

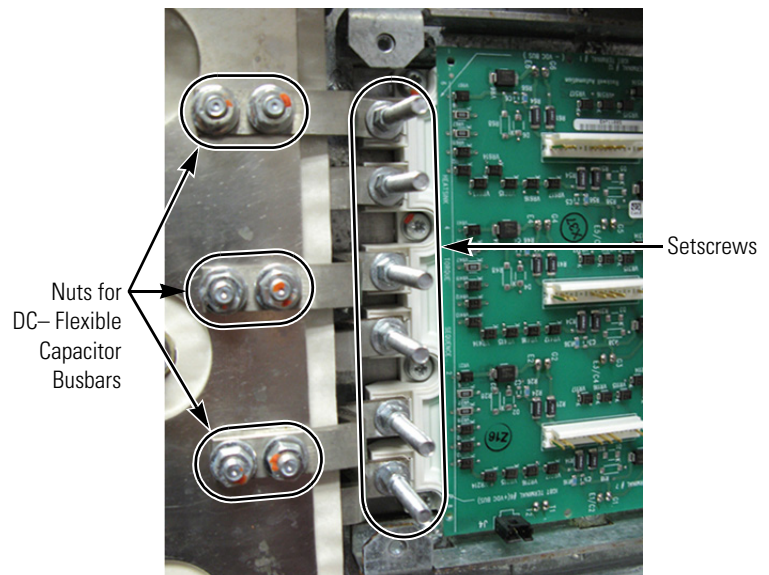

If replacing an IGBT module, remove the nuts and DC- flexible capacitor busbars, and save nuts and busbars.

7. Cut tie wraps for the balancing resistor wiring.
8. Disconnect the yellow wire for the balancing resistor.

You do not need to disconnect the blue and black wires.

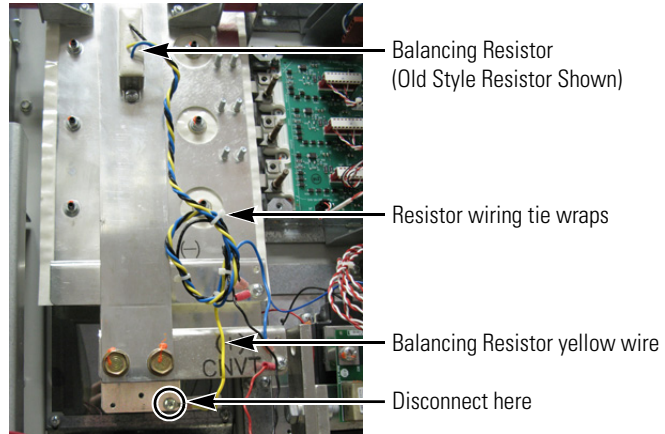

9. Remove the four side standoffs and brackets for the transitional busbar assembly.
10. Remove the 18 nuts fastening the transitional busbar assembly to the bus capacitors.

The setscrews may come out with the nuts. Save all nuts and setscrews.

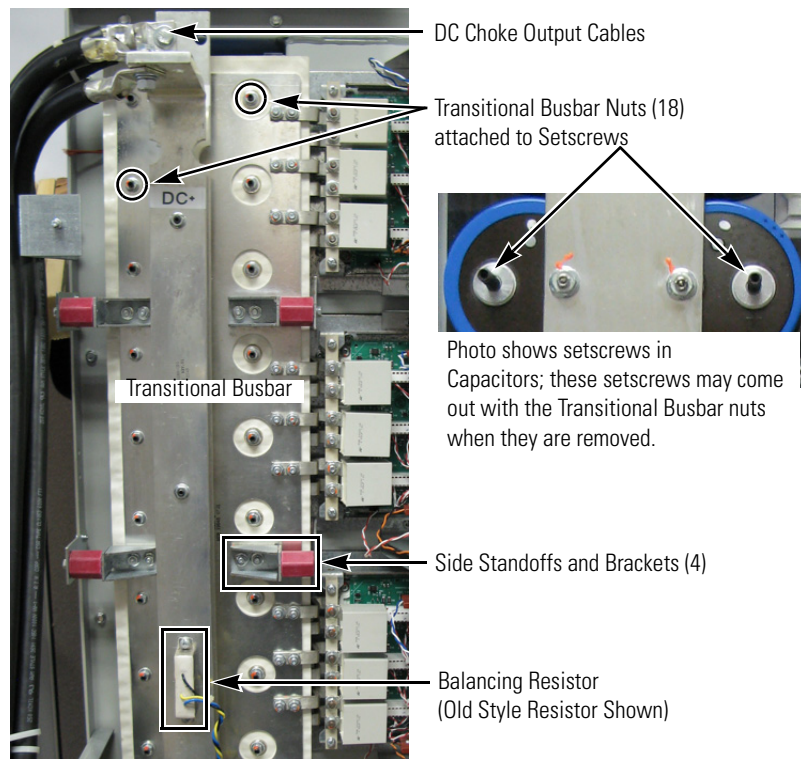

**11. Remove the transitional busbar assembly.**

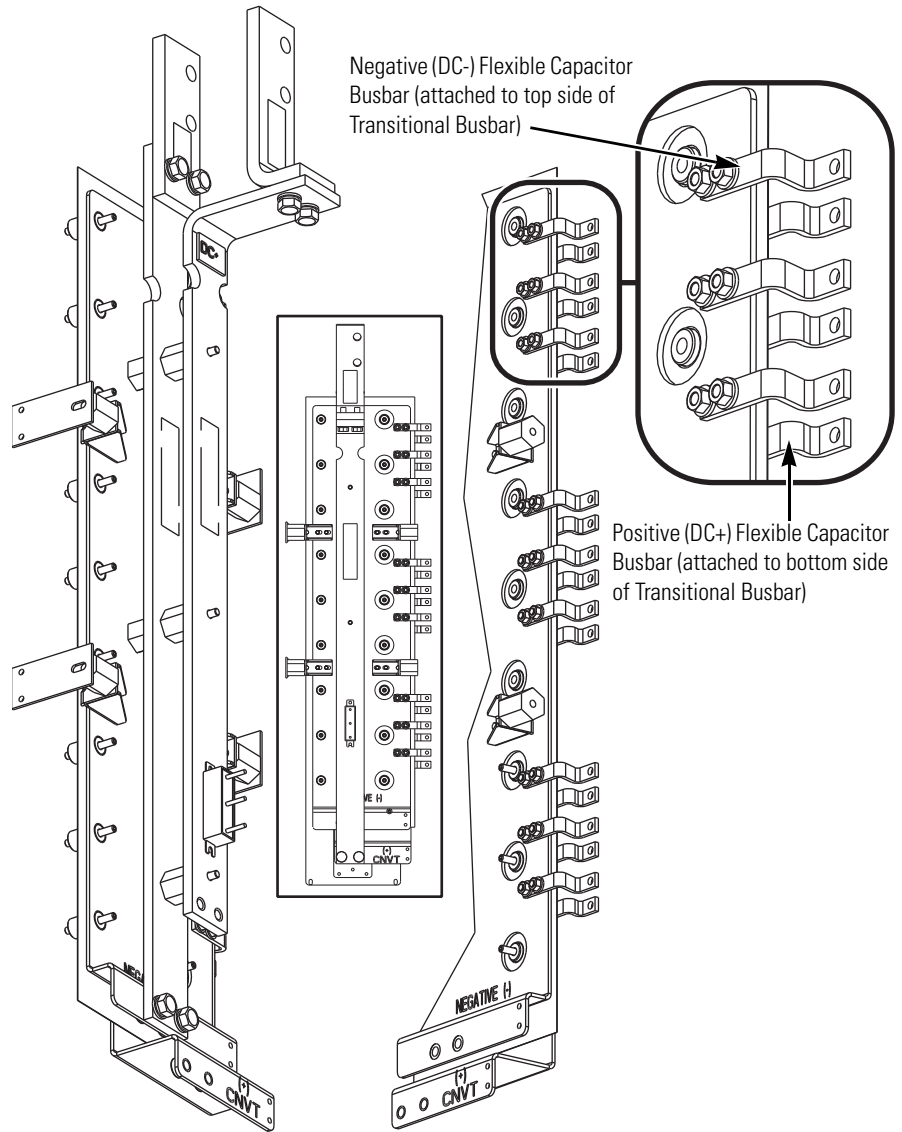

## Install Components

See the photographs in the preceding Transitional Busbar Assembly section to identify any components discussed in this section.

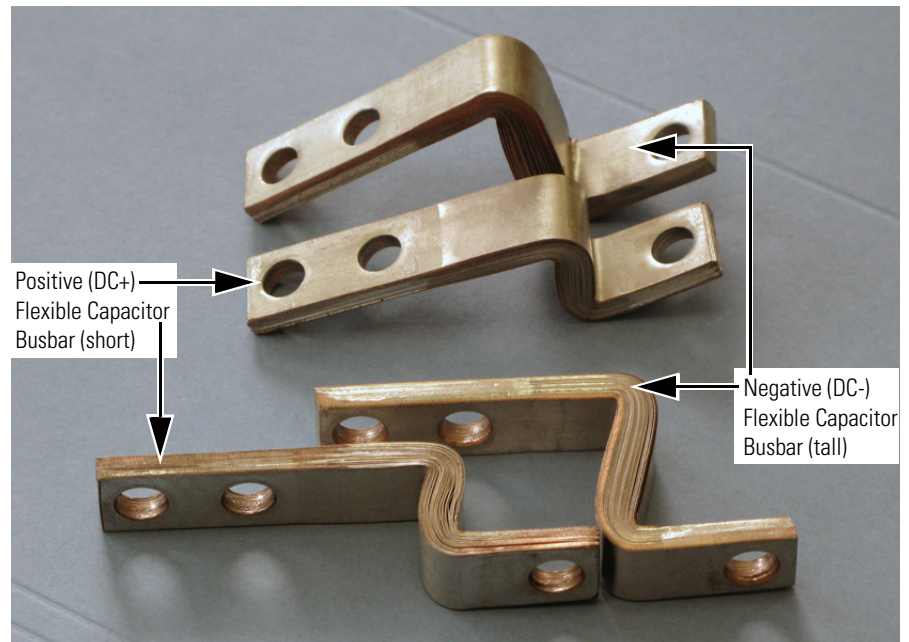

### IMPORTANT

Each IGBT replacement kit includes three positive (DC+) and three negative (DC-) flexible capacitor busbars. The positive ones are shorter (see above) because they attach to the back side of the transitional busbar. For ease of installation, replace positive flexible capacitor busbars while the transitional busbar is removed.

1. Replace the three positive (DC+) flexible capacitor busbars supplied in an IGBT replacement kit on the back side of the transitional busbar for each IGBT module being replaced.
2. Mount transitional busbar to bus capacitors. If needed, use a rubber mallet to gently tap the transitional busbar onto the longer setscrews of the bus capacitors.
3. Add a washer (rounded side down) and nut to each bus capacitor setscrew. Finger tighten only.
4. Install the nine negative flexible capacitor busbars to the transitional busbar with two washers (rounded side down) and two nuts for each flexible capacitor busbar. Finger tighten only.
5. Install the six setscrews to secure the flexible capacitor busbars to each IGBT board. Finger tighten only.



6. Reinstall the screws for the four side standoffs and brackets to secure the transitional busbar assembly to the chassis.
  - a. Torque the screws to 5.6 N•m (50 lb•in) to secure the brackets to the four red glastic spacers.
  - b. Torque screws to 2.9 N•m (26 lb•in) to secure the two brackets to the drive chassis.
7. Torque the six setscrews for each IGBT board to 5.6 N•m (50 lb•in).

---

**IMPORTANT**

When torquing down each setscrew, place a flathead screwdriver against the side of the flexible capacitor busbar to minimize twisting. **Do not** rest the screwdriver against any IGBT board while performing this task to avoid cracking or breaking the board.

---

8. Reinstall the tie down capacitor mount on each IGBT board.

Reinstall two screws simultaneously to secure each Mount. Torque screws to 2.9 N•m (26 lb•in).
9. Install three snubber resistors onto the six setscrews for each IGBT board.

Reinstall two screws to secure each snubber resistor against the tie down capacitor mount. Torque screws to 5.6 N•m (50 lb•in).
10. Torque the nuts that secure the nine negative flexible capacitor busbars to the transitional busbar to 5.6 N•m (50 lb•in).
11. Torque the nuts that secure the transitional bus bar to the bus capacitor setscrews to 5.6 N•m (50 lb•in).
12. Connect the yellow wire for the balancing resistor.
13. Install a new tie wrap for the balancing resistor wiring.
14. If present, connect the +DC IN and +DC OUT cables from the transitional busbar. Torque to 23.5 N•m (208 lb•in).
15. For AC input drives, reinstall the DC choke output cables. Torque to 9 N•m (80 lb•in).
16. Reinstall any customer wiring to the transitional busbar.
17. Reinstall the stacking panel as instructed on page [27](#).
18. Verify all wiring to the two panels and the transitional busbar has been reconnected.
19. Replace all safety shields and enclosure covers before applying power to the drive.

**Notes:**

## Component Replacement Procedures

### Overview

Component procedures detailed in this chapter apply to PowerFlex 700 Frame 8 drives for AC or DC input. Removal and replacement instructions for the stacking panel and transitional busbar assemblies are detailed in Chapter 2.

### Main Control Board

See Chapter 1 - Component Diagrams and Torque Specifications on page 15 to locate the component detailed in these instructions.

### Remove Components

1. Read and follow the Safety Precautions on page 12 and Important Initial Steps on page 13.
2. Remove safety shields as needed.

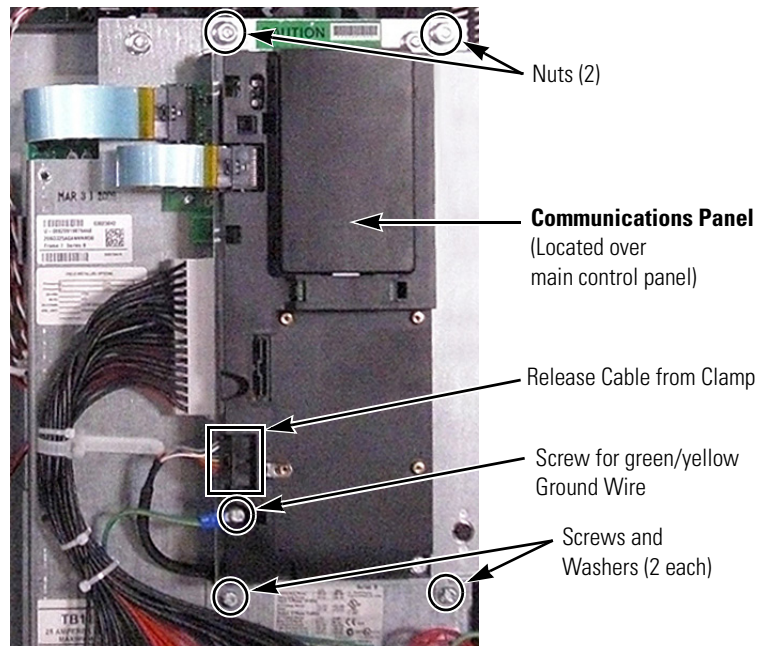

3. Unscrew the green/yellow ground wire from the communications panel.
4. Remove the two nuts and two screws and washers for the communications panel.

5. Disconnect both ribbon cables from the left side of the main control board.

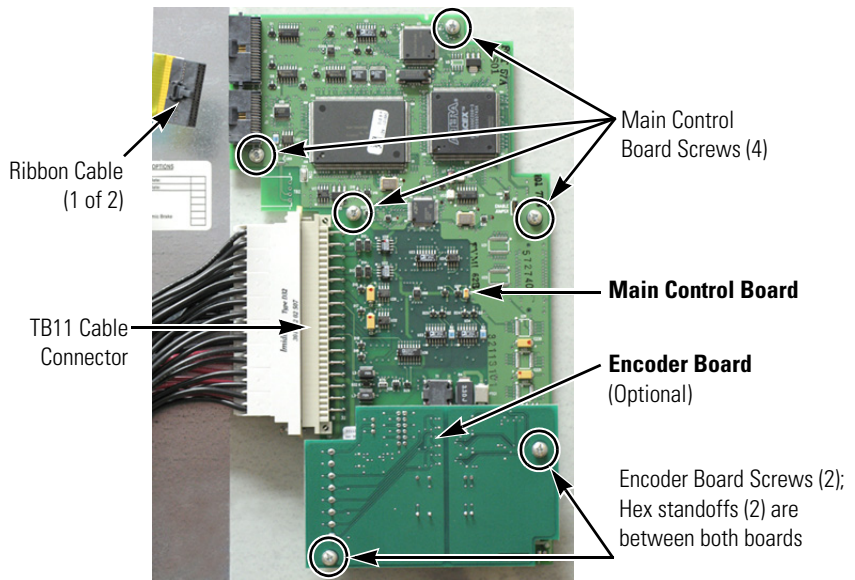

6. Hold the communications panel and release the cable at the bottom of the panel from its clamp (see previous page for its location) and set the communications panel aside.
7. If needed, unscrew and disconnect the connector from the main control board for the wire set going to TB11.  
Do not disconnect any wires from TB11.
8. If present, unscrew the two screws for the encoder board. Gently pull off the encoder board.
9. Unscrew the four screws and two hex standoffs holding the main control board.
10. Remove the main control board.

## Install Components

1. Install the new main control board with four screws and two hex standoffs. Torque the screws and standoffs to 2 N•m (14 lb•in).
2. Install the encoder board (if the optional encoder board was installed) with two screws. Be sure to match up the J7 connectors. Torque the screws to 2 N•m (14 lb•in).
3. Connect the ribbon cable and TB11 cable connector to the main control board.
4. Torque the two mounting nuts at the top of the communications panel to 5.6 N•m (50 lb•in).
5. Torque the two screws on the communications panel near TB11 to 3 N•m (26 lb•in).
6. Torque the screw for the green/yellow ground wire from TB11 to the HIM cradle/board to 1.6 N•m (14 lb•in).
7. Replace all safety shields and enclosure covers before applying power to the drive.

## T-Comm Board

See Chapter 1 - Component Diagrams and Torque Specifications on page 15 to locate the component detailed in these instructions.

### Remove Components

1. Read and follow the Safety Precautions on page 12 and Important Initial Steps on page 13.
2. Remove the main control board:
  - a. Remove the HIM board from its slot (if used).
  - b. Disconnect the ribbon cable from the main control board (connects to J10n power interface board).
  - c. Disconnect the wiring connector from the main control board (connects to 8-pin serial port in the lower-right corner of main control board panel).
  - d. Remove and save the grounding-wire screw (connects to PE on TB11).
  - e. Remove and save the two mounting screws for the HIM cradle/board.
  - f. Remove the HIM cradle/board.

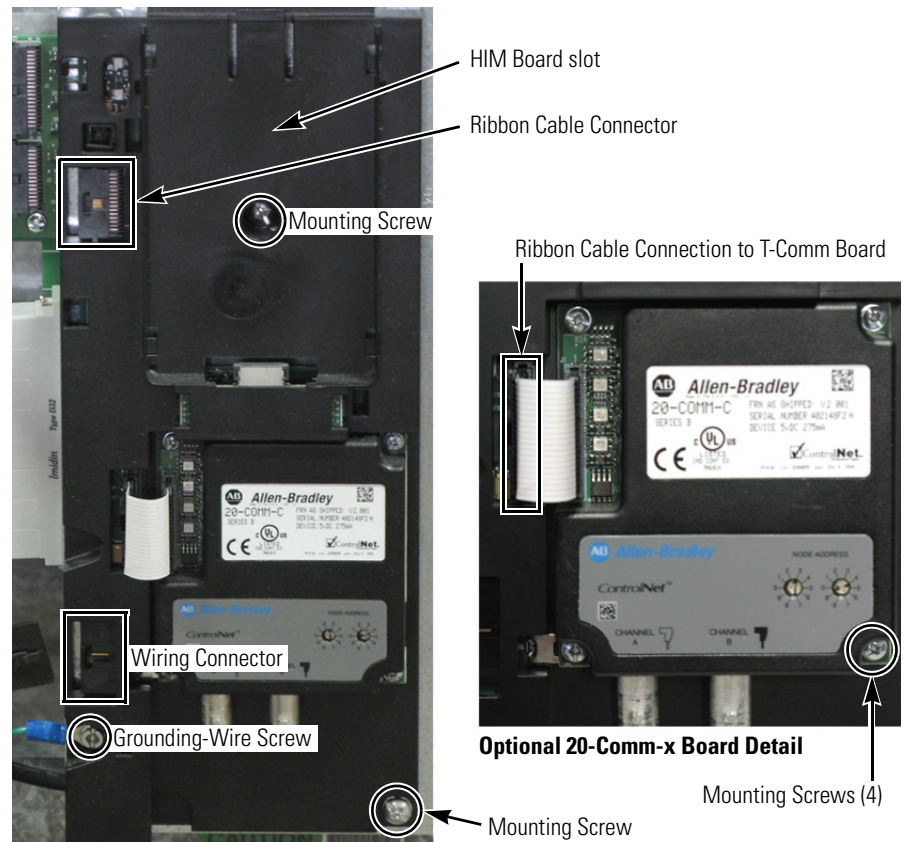

3. Remove the 20-Comm-x board (if used):
  - a. Disconnect the ribbon cable between the 20-Comm-x Board and T-Comm board; disconnect only from the T-Comm board.
  - b. Remove and save the four mounting screws.
4. If the 20-Comm-x board is not used, remove the screw securing the T-Comm grounding tab.



T-Comm grounding tab screw



T-Comm grounding tab flat



T-Comm grounding tab upright

5. Place the tip of a flathead screwdriver between the T-Comm grounding tab and screw mount.

Gently pry up until the grounding tab is in an upright position or about 90 degrees from the screw mount.

6. If needed, use the same flathead screwdriver tip to pry the seven locking tabs away from the T-Comm board.

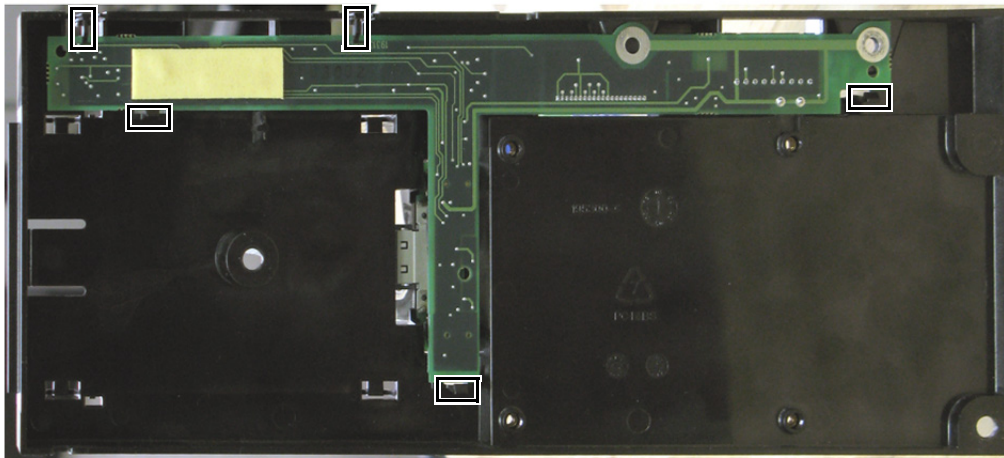

**T-Comm Board Locking Tab Locations**

Five locking tabs are on the back side of the main control board (above); two are on the front side in the area between the optional HIM and 20-Comm-x board slots (upper right).

**NOTE:** Use a flathead screwdriver tip to pry the locking tabs away from the T-Comm Board (lower right).

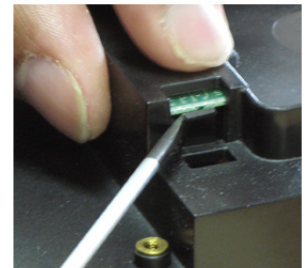
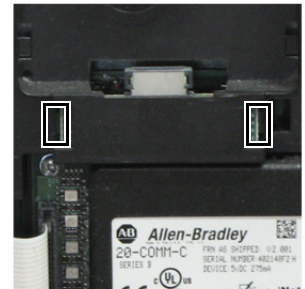

7. Remove the T-Comm board from the main control board.

## Install Components

1. Install the new T-Comm board.

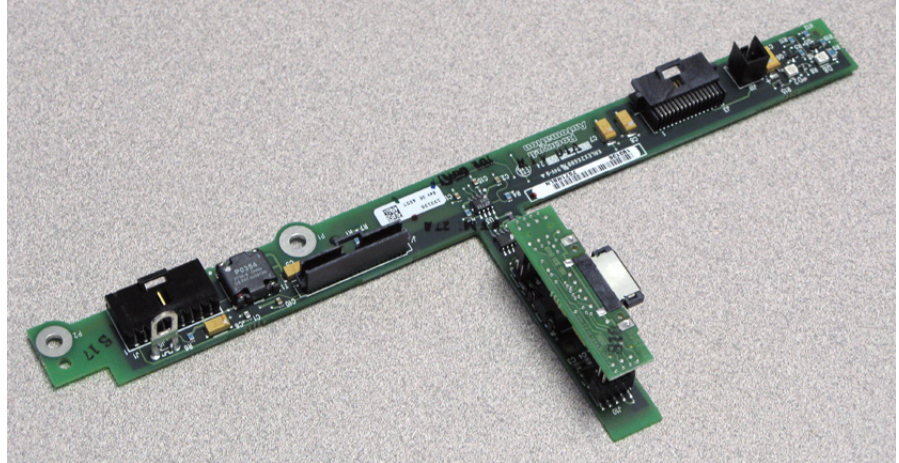

2. Verify the board is locked into all seven locking tabs.
3. Carefully bend the T-Comm grounding tab until it is flush with the screw mount on the main control board.
4. Install the 20-Comm-x board (if used). Torque the four mounting screws to 2.9 N•m (26 lb•in).
5. Install the HIM cradle/board. Torque the two mounting screws to 3 N•m (26 lb•in).
6. Install the screw for the green/yellow ground wire from TB11 to the HIM cradle/board. Torque the screw to 1.6 N•m (14 lb•in).
7. Connect the 8-pin wiring connector to the serial port.
8. Connect the ribbon cable.
9. Replace all safety shields and enclosure covers before applying power to the drive.

## Power Interface Board

See Chapter 1 - Component Diagrams and Torque Specifications on page 15 to locate the component detailed in these instructions.

### Remove Components

1. Read and follow the Safety Precautions on page 12 and Important Initial Steps on page 13.
2. Remove the main control panel as detailed on page 24.
3. Remove remaining wiring harnesses from the power interface board, including the wiring between the power interface board and the switch mode power supply board.

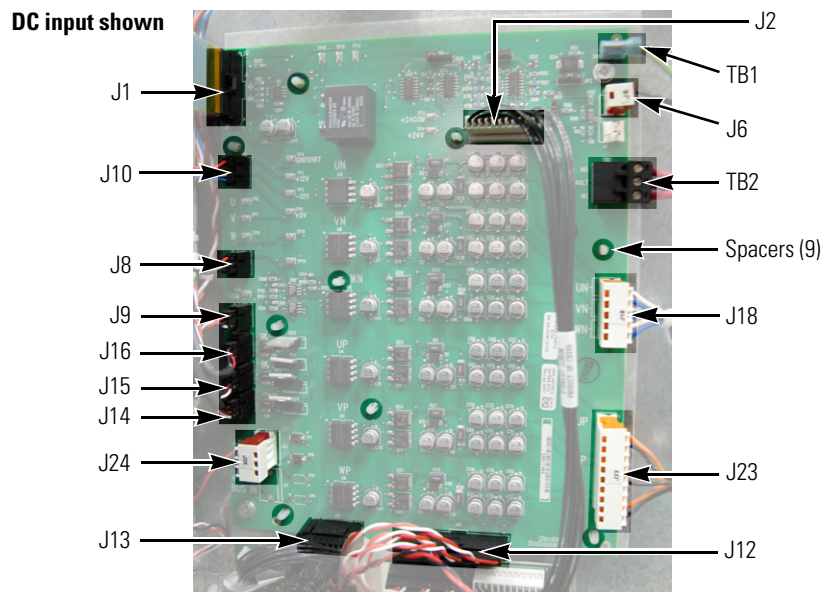

Refer to the illustration above for connector locations.

Connector	Wire Color(s)	Connects To:
J1	ribbon	J2 on main control board (ribbon cable)
J2	black	J1 on switch mode power supply board
J6	black	Monitor wire to thermal sensors
J8	red/white/black	J7-U on U phase gate interface board
J9	red/white/black	J1 on 24V power supply board
J10	red/black/white/blue	J3 on precharge board
J12	red/white	J3 on switch mode power supply board
J13	black	J2 on switch mode power supply board
J14	red/white/black	U phase current transducer
J15	red/white/black	V phase current transducer
J16	red/white/black	W phase current transducer
J18	blue/white	U, V, W negative (-) gates (lower phase)
J23	orange/black	U, V, W positive (+) gates (upper phase)



Connector	Wire Color(s)	Connects To:
<b>J24</b>	red/black	J1 on precharge board, TB1 on DC bus filter board (AC input only)
		TB1 on DC bus filter board (DC input only)
<b>TB1</b>	green/yellow	PE on TB11
<b>TB2</b>	red	#33, #34, and #35 on TB11

4. Remove the two power interface board mounting torx screws located at the upper right and lower left corners of the board as shown at right.
5. Use your fingers or needle-nose pliers to squeeze the tabs of each of the nine spacers (see previous page for their locations), and separate the power interface board from the mounting plate.
6. Remove the power interface board.

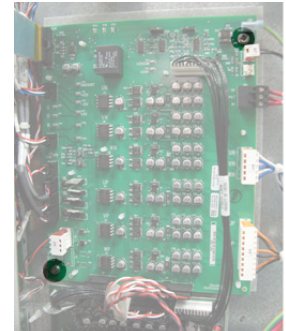

## Install Components

1. Install the new power interface board. Torque the two mounting screws to 1.7 N•m (15 lb•in).
2. Connect all wiring. For the ribbon cable going from the power interface board (J1) to the main control board (J2), connect the cable at J1 on the power interface board.
3. Reinstall the main control panel. See page [24](#).
4. Replace all safety shields and enclosure covers before applying power to the drive.

## Switch Mode Power Supply Board

See Chapter 1 - Component Diagrams and Torque Specifications on page 15 to locate the component detailed in these instructions.

### Remove Components

1. Read and follow the Safety Precautions on page 12 and Important Initial Steps on page 13.
2. Remove the main control panel as detailed on page 24.
3. Disconnect all cables (J2, J4, J3, J1) from the switch mode power supply board.
4. Remove the switch mode power supply board mounting torx screw located at the lower right corner of the board.
5. Use your fingers or needle-nose pliers to squeeze the tabs of each of the three spacers and separate the switch mode power supply board from the mounting plate.
6. Remove the switch mode power supply board.

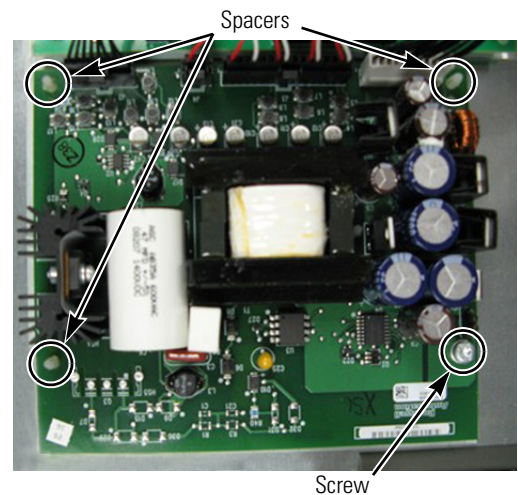

### Install Components

1. Install the new switch mode power supply board. Torque the mounting screw to 1.7 N•m (15 lb•in).
2. Connect J2, J4, J3, and J1 cables.
3. Reinstall the main control panel. See page 24.
4. Replace all safety shields and enclosure covers before applying power to the drive.

## Precharge Board

See Chapter 1 - Component Diagrams and Torque Specifications on page [15](#) to locate the component detailed in these instructions.

### Remove Components

1. Read and follow the Safety Precautions on page [12](#) and Important Initial Steps on page [13](#).
2. Remove the safety cover over the precharge board.
3. **For DC input only:** Verify that customer wiring to TB2 is properly labeled and then disconnect wiring from TB2.
4. Using pliers if needed, remove the three wiring/harnesses (J1, J2, J3).

**Note:** Some connectors may not be labeled. Label them if needed.

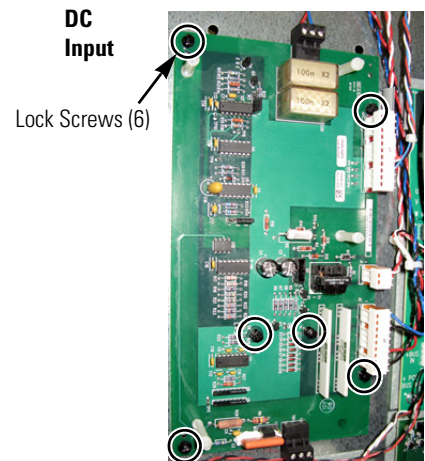
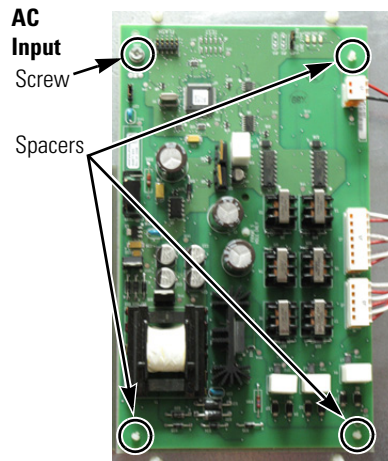

5. **For AC input:** Remove the precharge board mounting torx screw located at the upper left corner of the precharge board.
6. **For AC input:** Use your fingers or needle-nose pliers to squeeze the tabs of each of the three spacers and separate the precharge board from the mounting plate.
7. **For DC input:** Turn each of the six lock screws 1/4 turn counterclockwise to unlock.
8. Remove the precharge board.

### Install Components

1. Install the new precharge board.
  - **For AC input:** Torque the mounting screw to 1.7 N•m (15 lb•in).
  - **For DC input:** Turn each of the six lock screws 1/4 turn clockwise to lock.
2. Connect the wiring.
3. Replace all safety shields and enclosure covers before applying power to the drive.

## DC Bus Filter Board

See Chapter 1 - Component Diagrams and Torque Specifications on page 15 to locate the component detailed in these instructions.

### Remove Components

1. Read and follow the Safety Precautions on page 12 and Important Initial Steps on page 13.
2. Remove the safety cover over the DC bus filter board.
3. Disconnect red and black wires from TB1 and TB2 terminals.
4. Remove the four mounting bolts.
5. Remove the DC bus filter board.

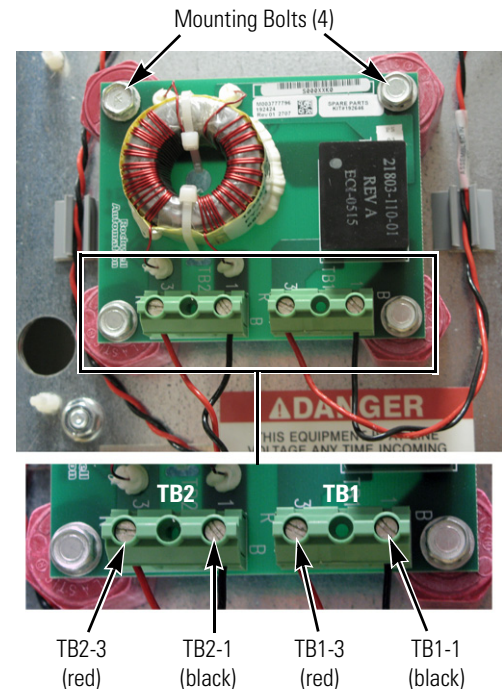

### Install Components

1. Install the new DC bus filter board. Torque the four mounting bolts to 1.7 N•m (15 lb•in).
2. Connect the red and black wires to TB1 and TB2 terminals as shown at right.
3. Replace all safety shields and enclosure covers before applying power to the drive.

## Bus Capacitor

See Chapter 1 - Component Diagrams and Torque Specifications on page [15](#) to locate the component detailed in these instructions.

### Remove Components

1. Read and follow the Safety Precautions on page [12](#) and Important Initial Steps on page [13](#).
2. Remove the transitional busbar assembly as detailed on page [28](#).

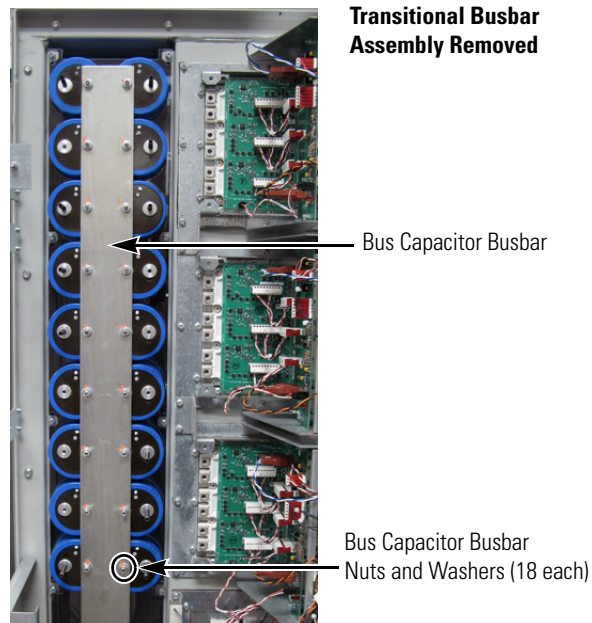

3. Label and remove all wires and connectors from the bus capacitor busbar.
4. Remove nuts and washers (18 each) fastening the bus capacitor busbar to the capacitors.
5. Remove the bus capacitor busbar.
6. Remove the capacitors.

## Install Components



**ATTENTION:** Install each capacitor so **its vent plug is at the top** or 12 o'clock. Component and system damage may result if you position any bus capacitor incorrectly.

1. Use a 3 mm angle hex wrench to replace the setscrews for each new capacitor. Torque to 0.7 N•m (6 lb•in).

**IMPORTANT** Each capacitor needs a short and long setscrew. See the illustration below for where to install each setscrew.

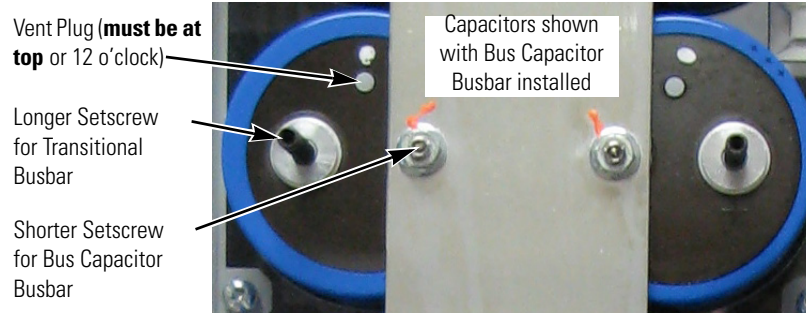

2. Place capacitors into correct position in drive (vent plug at top or 12 o'clock).
3. Place bus capacitor busbar onto capacitors.
4. Install the 18 washers and nuts onto setscrews, but do not tighten yet.
5. Place the transitional busbar in position. Make sure that all setscrews, washers, and nuts fit. Adjust as needed.
6. Remove the transitional busbar, and tighten all washers and nuts for the bus capacitor busbar. Torque to 5.6 N•m (50 lb•in).
7. Install the transitional busbar assembly as detailed on page [28](#).
8. Replace all safety shields and enclosure covers before applying power to the drive.

## Capacitor Bank Fan

See Chapter 1 - Component Diagrams and Torque Specifications on page [15](#) to locate the component detailed in these instructions.

### Remove Components

1. Read and follow the Safety Precautions on page [12](#) and Important Initial Steps on page [13](#).
2. Remove the stacking panel as detailed on page [26](#).
3. Label and disconnect all wires for the fan.
4. Remove the four mounting screws.
5. Remove the fan assembly.

Four Mounting Screw

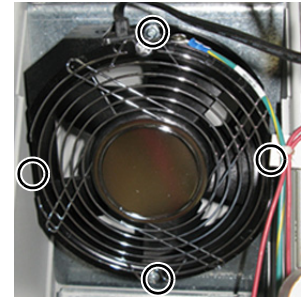

### Install Components

1. Install the new fan assembly. Torque the four mounting screws to 1.8 N•m (16 lb•in).
2. Connect the wires.
3. Install the stacking panel as detailed on page [26](#).
4. Replace all safety shields and enclosure covers before applying power to the drive.

## Balancing Resistor and DC+ Bus Bar

See Chapter 1 - Component Diagrams and Torque Specifications on page 15 to locate the component detailed in these instructions.

### Remove Components

1. Read and follow the Safety Precautions on page 12 and Important Initial Steps on page 13.
2. Remove the stacking panel as detailed on page 26.
3. Verify the rating of the resistors to be sure there was no damaged during shipment ( $R1$  to  $R2 = R2$  to  $R3 = 6.8\text{ k}\Omega \pm 5\%$ ).

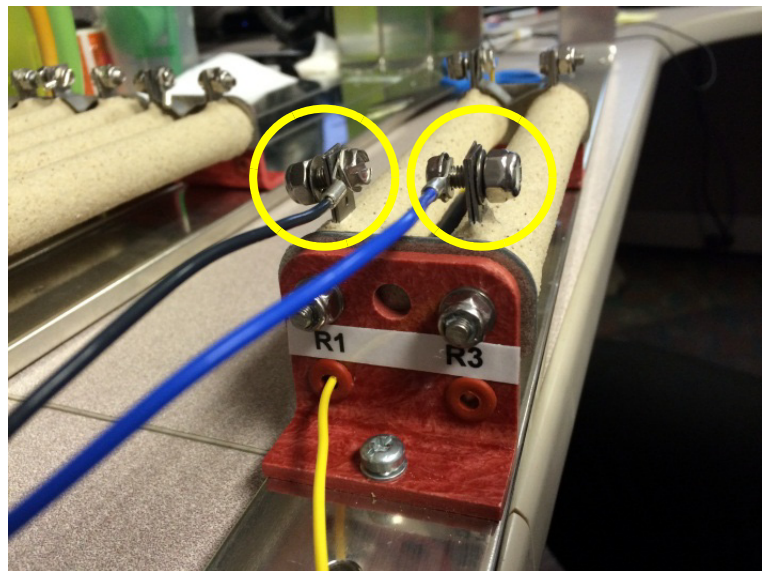

---

**IMPORTANT** Do not install the resistor if the measurement is not within the recommended range.

---



4. Because the existing resistor wires will be reused, cut the wires off of the resistor at the solder joint, to keep the wires as long as possible.

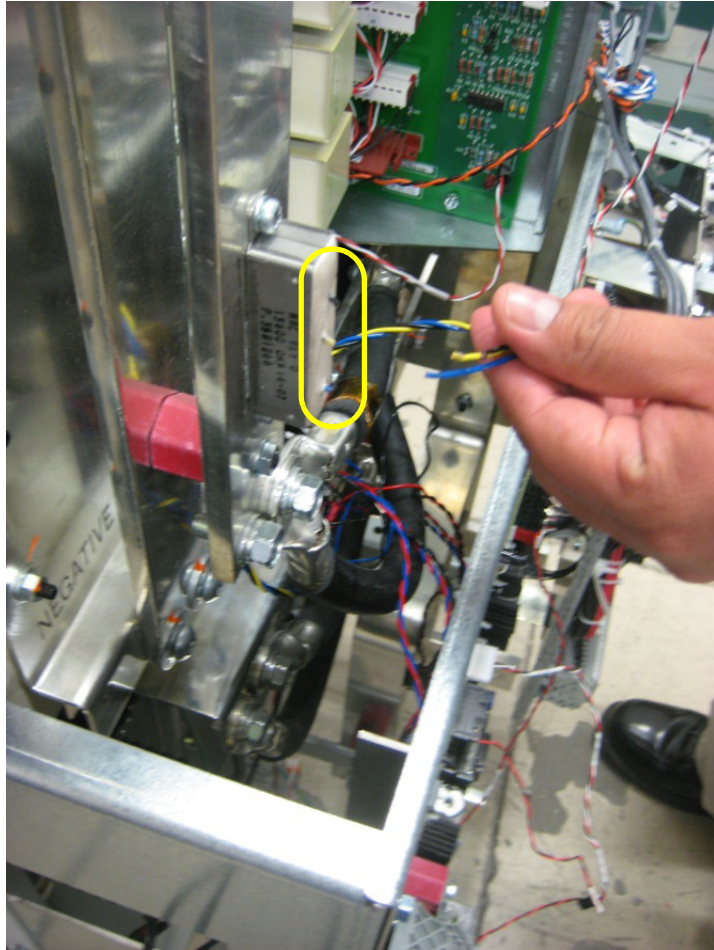

5. Strip the tip of each wire to approximately 6 mm (0.24 in.).

6. Cut and remove the tie wraps that secure the resistor wire bundle.

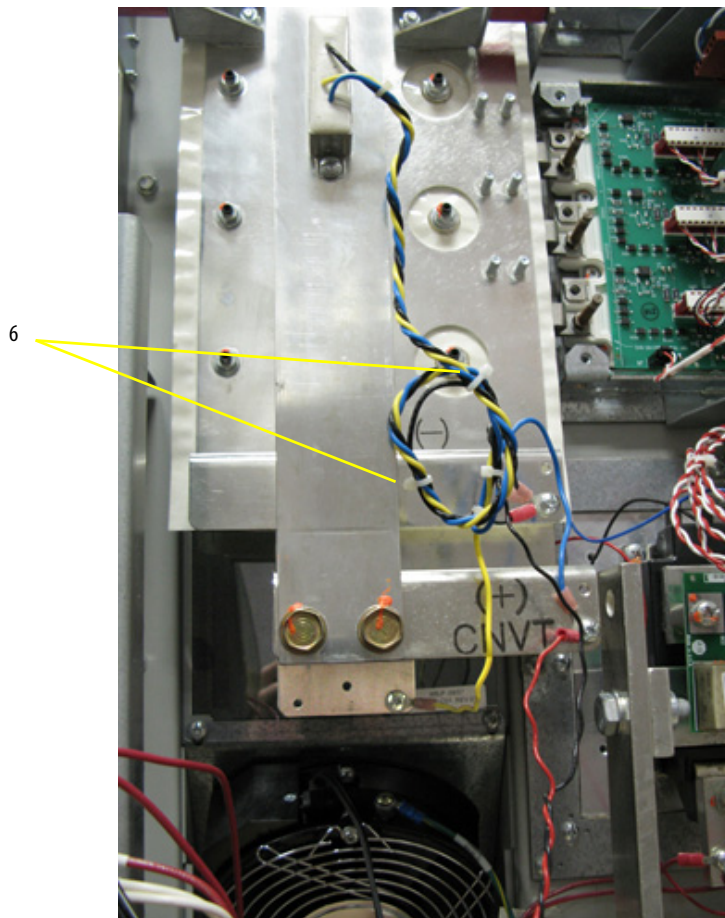

7. Remove the bolts between the right-angled bus bar and the large bus bar.

---

**IMPORTANT** Do not remove the bolts that attach the cables to the right-angled bus bar.

---

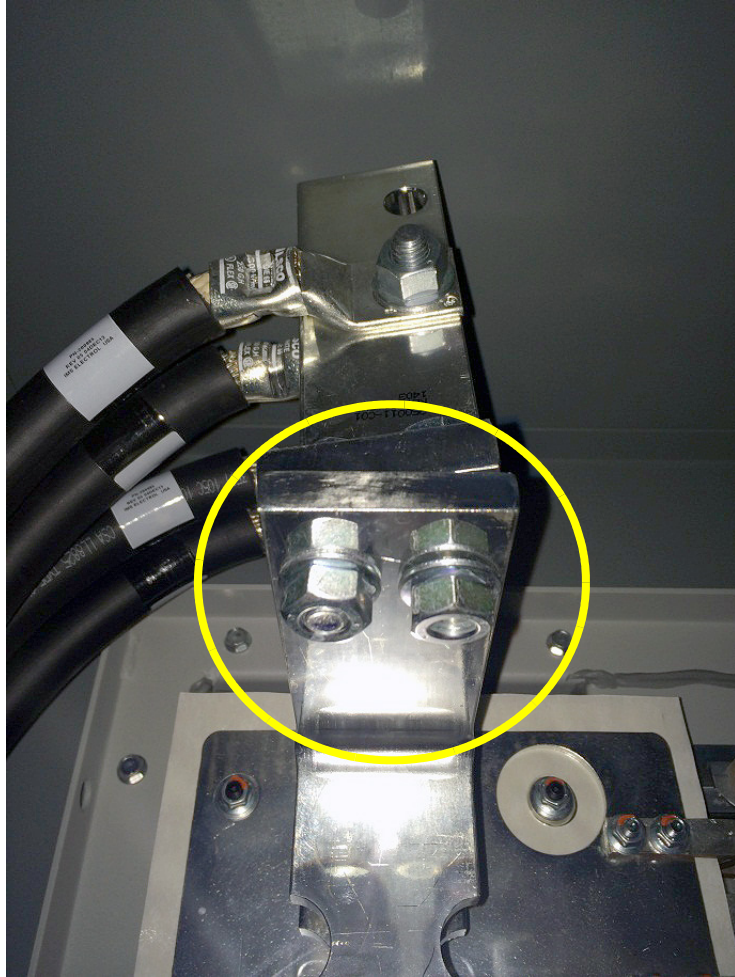

8. Remove the two bolts from the bottom of the bus bar (as shown in the following image).

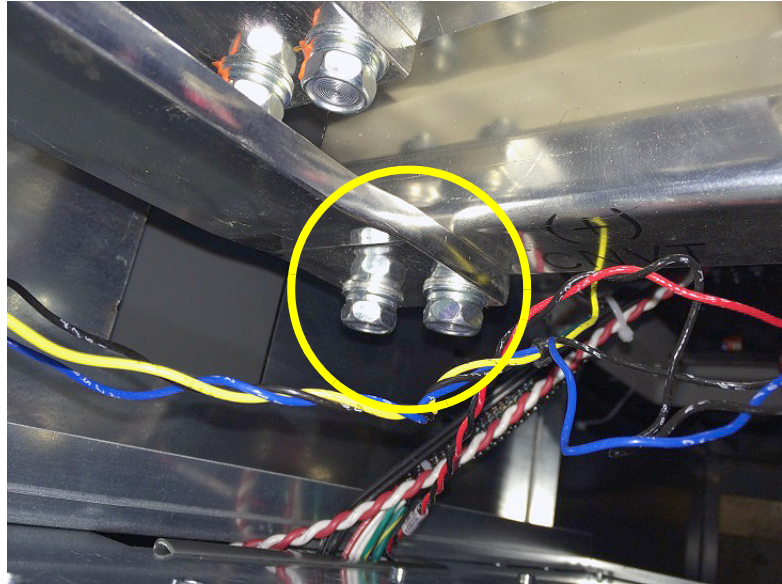

9. While holding the bus bar, remove the nuts that secure the bus bar to the chassis and remove the bus bar.

---

**IMPORTANT** The set screws can come out when a nut is removed.

---

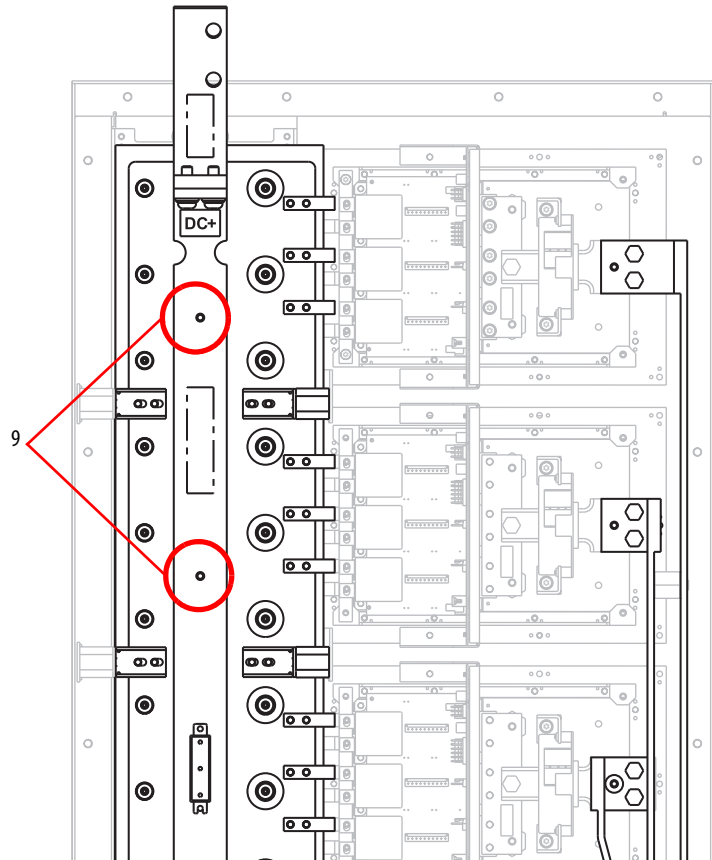

## Install Components

1. Install the set screws and nuts removed in step 2 on page 53. Tighten the nuts to 5.65 N•m (50 lb•in).

Frame 8 Drive Shown

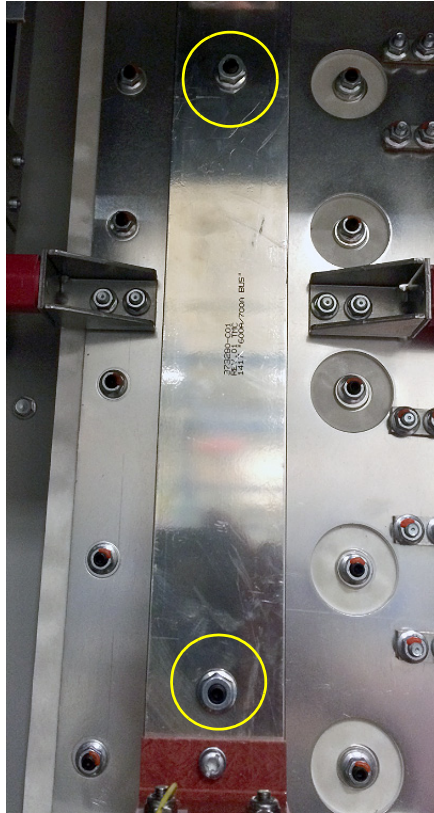

2. Install the bolts removed in step 8 on page 52. Tighten the bolts to 23.5 N•m (208 lb•in).
3. Install the bolts removed in step 7 on page 51. Tighten the bolts to 23.5 N•m (208 lb•in).

4. Verify that the yellow resistor wire is long enough to connect to the left terminal (R2) on the top of the resistor assembly. To do so, route the wire through the bottom and out of the top of the holes in the insulator material on the resistor assembly (as shown in the following images).

Note: If the yellow resistor wire is not long enough to reach the top terminal (R2) when routed through the assembly, it is acceptable to leave the wire outside of the assembly to make the connection.

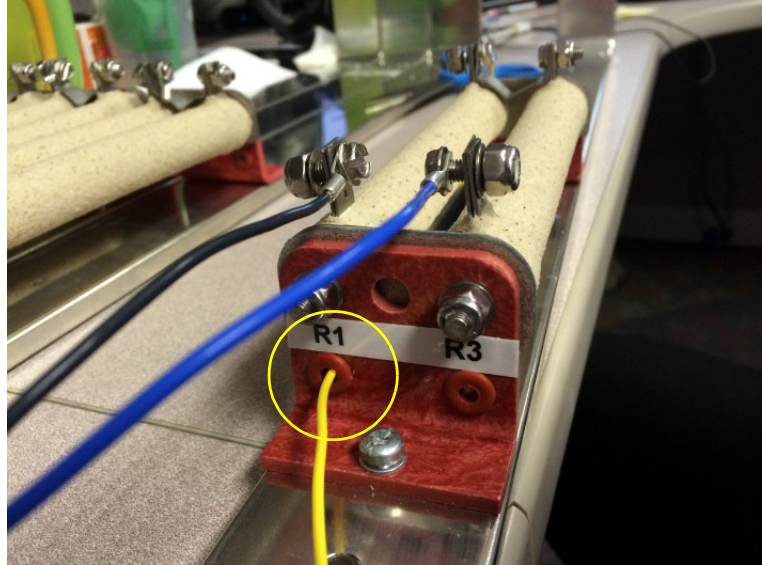

5. Remove the lugs from the resistor terminals and, using an 18 AWG wire crimper for a non-insulated connector, crimp the wires to the lugs.
6. Secure the lug with the black resistor wire to the left terminal (R1) on the bottom of the resistor assembly.
7. Secure the lug with the blue resistor wire to the right terminal (R3) on the bottom of the resistor assembly.
8. Secure the lug with the yellow resistor wire to the left terminal (R2) on the top of the resistor assembly.

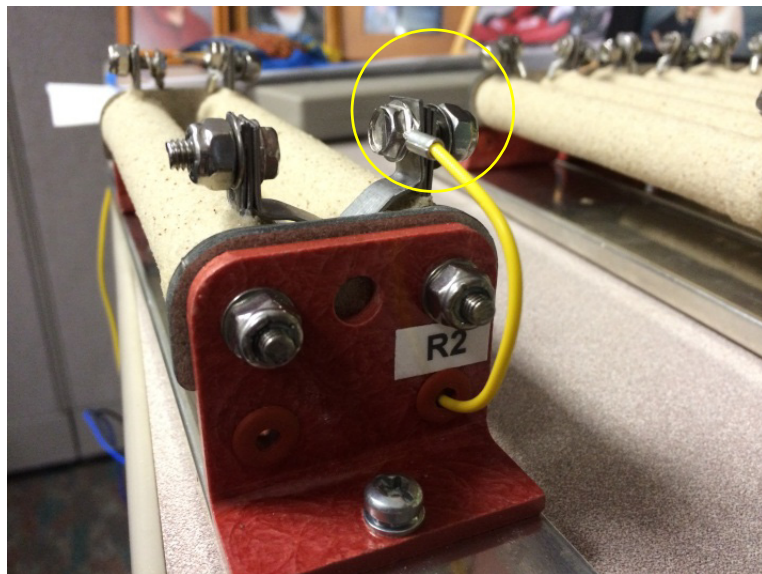
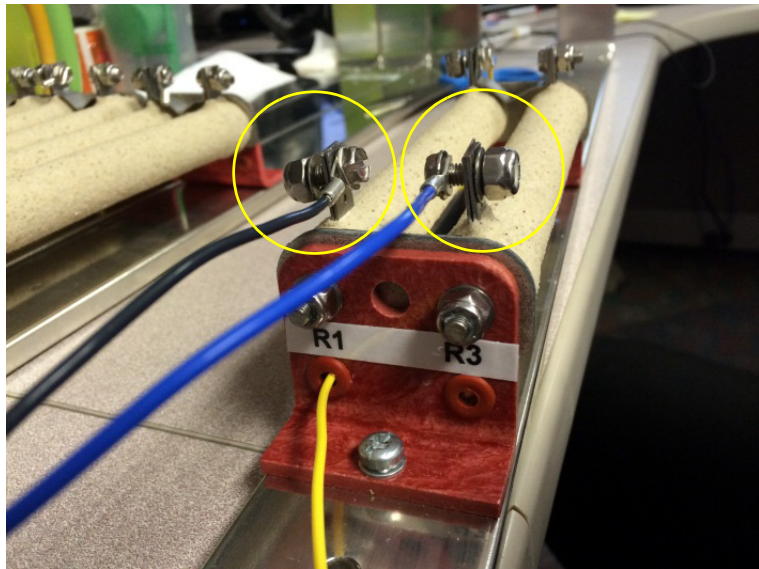



9. Secure the resistor wire bundle below the assembly using tie-wraps (as shown in the following image).

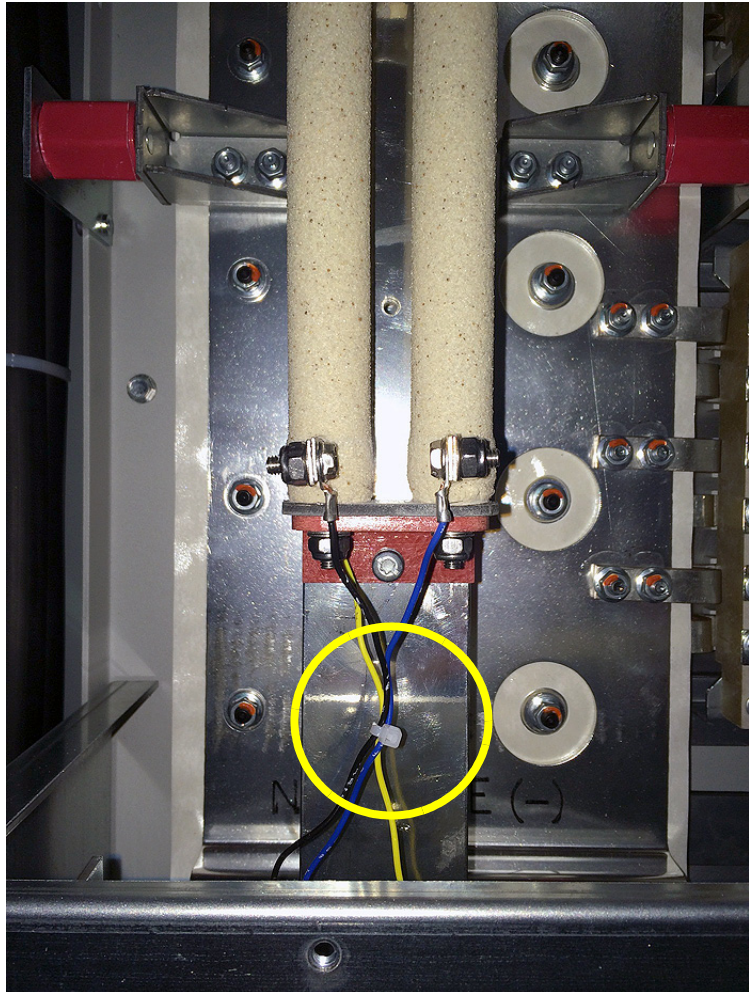

10. Install the stacking panel as detailed on page [26](#).
11. Replace all safety shields and enclosure covers before applying power to the drive.

## Inverter Power Module (IGBT)

The kit includes:

Qty.	Component
1	IGBT module with circuit board
1	gate interface board
1	Gate interconnect harness
3	Flexible capacitor busbar, positive (+)
3	Flexible capacitor busbar, negative (-)
1	Tie down capacitor mount
3	Snubber capacitor

**IMPORTANT** If any IGBT module is damaged, all IGBT modules and associated components should be replaced. Perform the following procedure for all IGBT modules.

Refer to the figures in Chapter 1 - Component Diagrams and Torque Specifications on page 15 for these instructions.

### Remove Components

1. Read and follow the Safety Precautions on page 12 and Important Initial Steps on page 13.
2. Remove the stacking panel as detailed on page 26.
3. Remove the AC output busbar at the current transducer:
  - a. Remove and save the three bolts that secure the output busbar to the AC output busbar and to the U, V or W busbar.

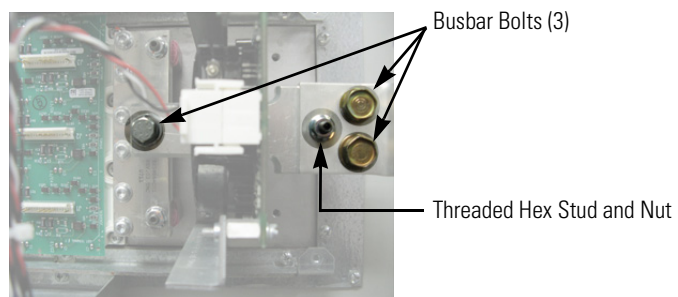

- b. Remove and save the nut and threaded hex stud for the standoff.
  - c. Slide the output busbar to the right as far as it goes.
  - d. Remove and save the six screws that secure the AC output busbar to the IGBT, and two nuts that secure the AC output busbar to its standoffs. Remove and save the AC output busbar.
4. Remove transitional busbar assembly as detailed on page 28.

5. Remove the gate interface board. See page 62.

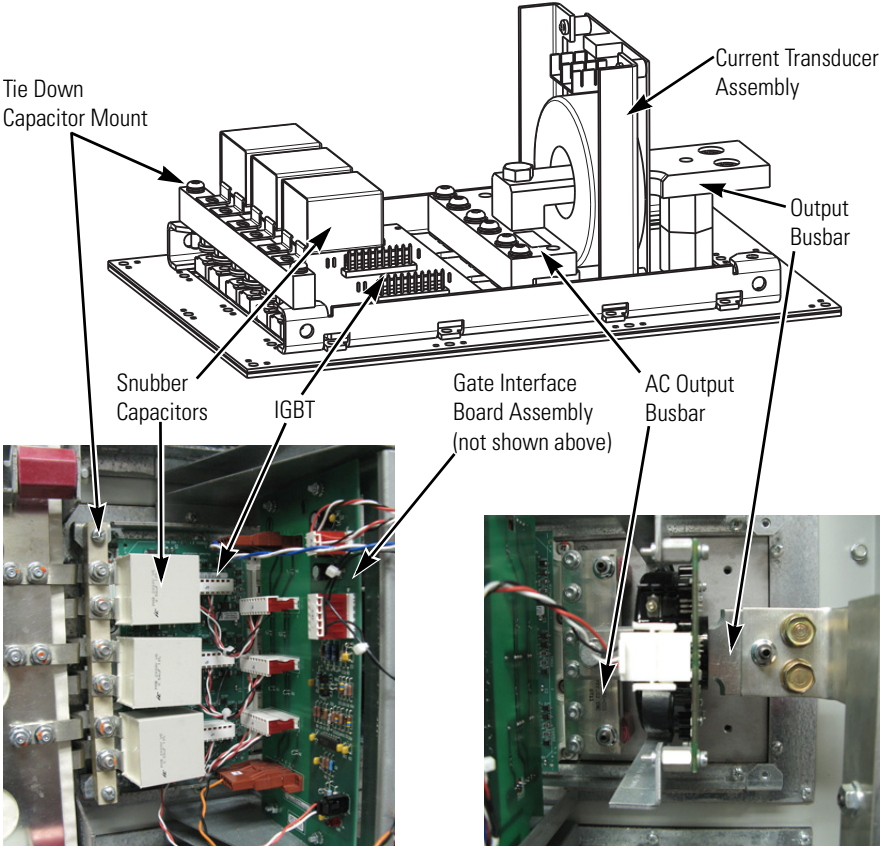

6. Carefully examine the transitional busbar and bus capacitors for damage. When replacing any IGBT, Rockwell Automation recommends that you replace all bus capacitors. If needed, refer to Bus Capacitor on page 45 to replace damaged bus capacitors.

**Example of IGBT Module Failure**

- Bus Capacitor, under Transitional Busbar
- Transitional Busbar
- Flexible Capacitor Busbars

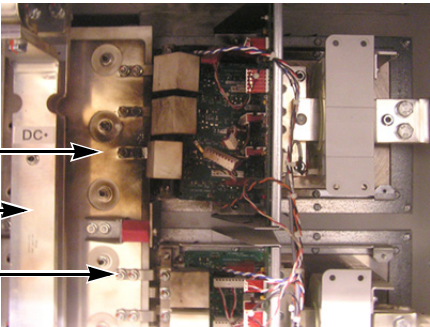

7. Remove the eight screws that secure the IGBT to the chassis.  
8. Remove the IGBT by tipping the right edge out first.

## Install Components

1. Install the IGBT module.
  - a. Use isopropyl alcohol to thoroughly clean the mounting surface of the heatsink and the mounting surface of the new IGBT module.
  - b. Use a 3- or 4-inch paint roller or putty knife to apply a thin, even coating of the supplied thermal grease to the mounting surface of the IGBT module.

In the next step, take care to not disturb any of the thermal grease on the IGBT module.

- c. Place the IGBT on the chassis with the serial number label at the top. Install with supplied screws using this torque sequence:

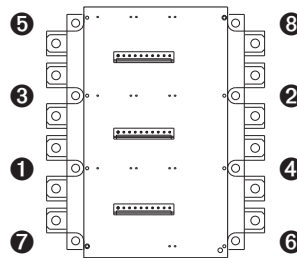

IGBT Torque Sequence  
 First Sequence: 0.7 N•m (6.0 lb•in)  
 Second Sequence: 2.3 N•m (20 lb•in)  
 Final Sequence: 5.6 N•m (50 lb•in)

2. Install the three supplied positive flexible capacitor busbars in positions 2, 4, and 6 on the IGBT.

The positive flexible capacitor busbars have a shorter angle.

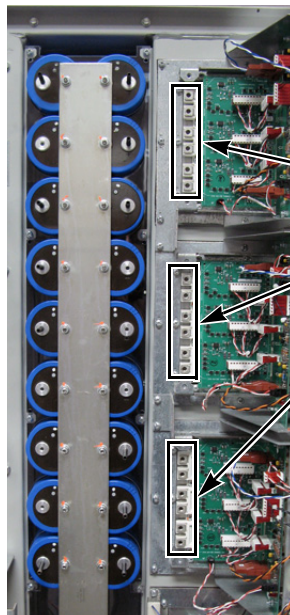

Shown with Transitional Busbar and all Flexible Capacitor Busbars installed for illustration purposes only.

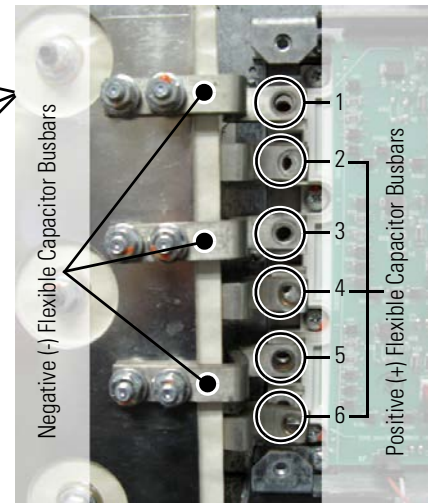

3. Install the transitional busbar assembly. See page [28](#).

Only torque nuts and screws after all components are in place.

4. Install the three supplied negative flexible capacitor busbars in positions 1, 3, and 5 on the IGBT.

The negative flexible capacitor busbars have a higher angle.

5. Install the tie down capacitor mount:

- a. Insert the short ends of the six threaded studs with nuts through the flexible capacitor busbars and into the left side of the IGBT. Torque to 5.6 N•m (50 lb•in).



**WARNING:** Correct torque is critical to ensure correct operation of the drive. Improper torquing could cause premature failure when attempting to operate the drive.

- b. Install the tie down capacitor mount with the two screws previously removed from the top and bottom of the capacitor mount. Torque to 2.9 N•m (26 lb•in).
6. Install the AC output busbar, output busbar, and current transducer:
    - a. Secure the AC output busbar to the two standoffs using the two nuts previously removed. Torque nuts to 5.6 N•m (50 lb•in).
    - b. Secure the AC output busbar to the IGBT by inserting six screws into the IGBT. Torque screws to 5.6 N•m (50 lb•in).
    - c. If removed, insert the output busbar through the current transducer assembly with the large end to the right.
    - d. Secure the current transducer assembly (transducer and brackets) using the two screws that were removed with the assembly. Torque to 2.9 N•m (26 lb•in).
    - e. Secure the left end of the output busbar to the AC output busbar with one screw. Torque to 9.0 N•m (80 lb•in).
    - f. Secure the other end of the output busbar to the U, V, or W busbar with the setscrew and nut. Torque the nut to 5.6 N•m (50 lb•in).
    - g. Install the two screws that connect the output busbar to the U, V, or W busbar. Torque to 9.0 N•m (80 lb•in).
  7. Install the gate interface board:
    - a. Install the gate interface board using the four nuts removed previously. Torque screws to 2.9 N•m (26 lb•in).
    - b. Install the supplied gate interconnect harness.
    - c. Connect wiring between the IGBT and gate interface board as shown in Gate Interface Board on page [62](#).
    - d. Connect wires to the current transducer.
  8. Install the three snubber capacitors in the reverse order of the removal instructions detailed on page [29](#). Torque nuts to 5.6 N•m (50 lb•in).
  9. Replace all safety shields and enclosure covers before applying power to the drive.

## Gate Interface Board

See Chapter 1 - Component Diagrams and Torque Specifications on page 15 to locate the component detailed in these instructions.

### Remove Components

1. Read and follow the Safety Precautions on page 12 and Important Initial Steps on page 13.
2. Remove the safety cover over the gate interface board.
3. Label and disconnect all wires (J1...J8).
4. Remove the four mounting nuts and remove the board.

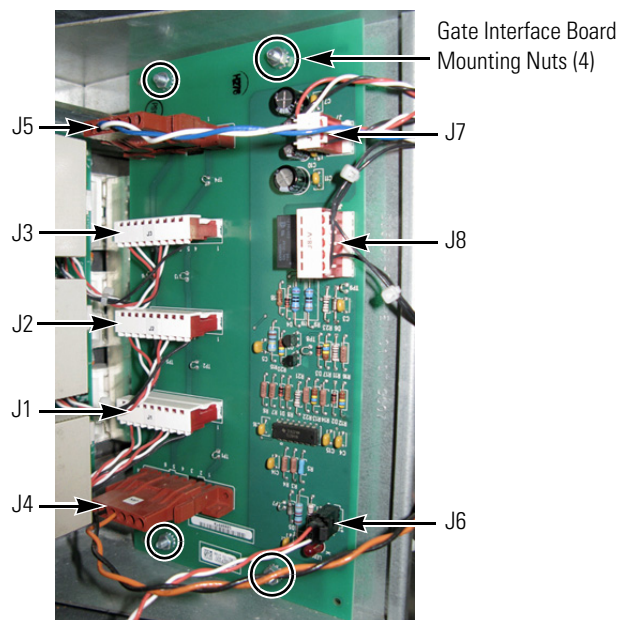

### Install Components

1. Install the new board. Torque the four mounting nuts to 1.8 N•m (16 lb•in).
2. Connect J1...J8 wires as shown above.  
**NOTE:** J4 from the corresponding IGBT connects to J6 on the gate interface board.
3. Replace all safety shields and enclosure covers before applying power to the drive.

## Current Transducer

See Chapter 1 - Component Diagrams and Torque Specifications on page [15](#) to locate the component detailed in these instructions.

### Remove Components

1. Read and follow the Safety Precautions on page [12](#) and Important Initial Steps on page [13](#).
2. Label and disconnect the wire from the transducer.

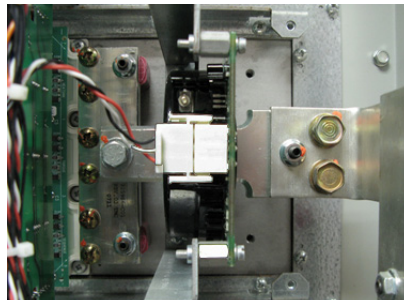

3. Remove the two 17 mm bolts and one 11 mm nut that connect the U, V, or W busbar to the output busbar.

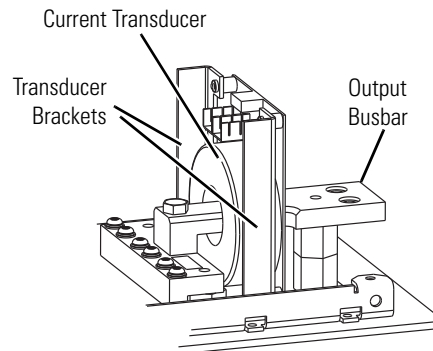

4. Remove the bolt on the left end of the output busbar.
5. Use a hex wrench to remove the setscrew.

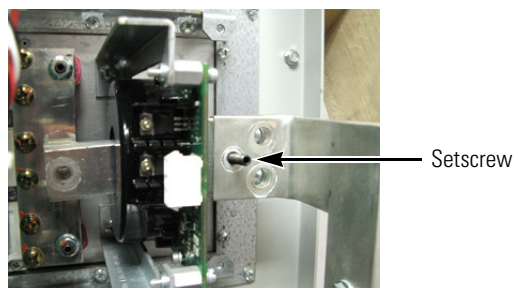

6. Remove the two screws that secure the transducer assembly to the backplane (transducer and brackets).

7. Remove assembly by lifting the assembly up and turning it slightly counterclockwise while rotating the top of the output busbar toward you and around the U, V, or W busbar.
8. Move the busbar and transducer to an ESD-safe flat surface for working with it.
9. Separate the transducer from the brackets.

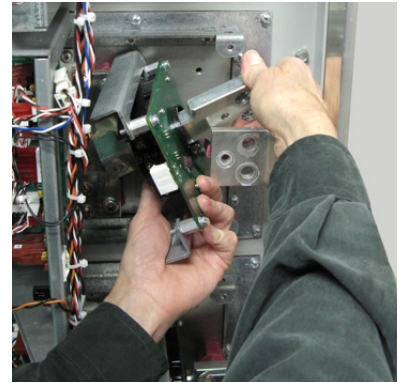

## Install Components

1. Mount brackets to the transducer. Torque screws to 1.6 N•m (14 lb•in).
2. Slide output busbar through the current transducer assembly with the angled end to the left.
3. Replace the current transducer assembly in mounting position by reversing the process used in [Step 7](#) of the removal process.
4. Secure the transducer assembly to the drive chassis with two screws. Torque to 2.9 N•m (26 lb•in).
5. Replace the output busbar setscrew and nut. Torque the nut to 5.6 N•m (50 lb•in).
6. Install the three output busbar bolts. Torque to 9.0 N•m (80 lb•in).
7. Connect the wires.
8. Replace all safety shields and enclosure covers before applying power to the drive.



## Converter Power Module - (SCR) AC Input Only

**IMPORTANT** If any converter SCR module fails, all three SCR modules should be replaced (kit includes three SCR modules).

See Chapter 1 - Component Diagrams and Torque Specifications on page [15](#) to locate the component detailed in these instructions.

### Remove Components

1. Read and follow the Safety Precautions on page [12](#) and Important Initial Steps on page [13](#).
2. Remove the stacking panel as detailed on page [28](#).

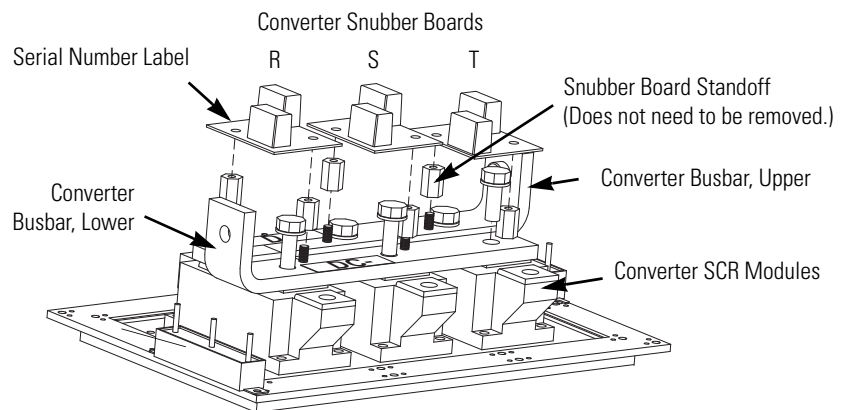
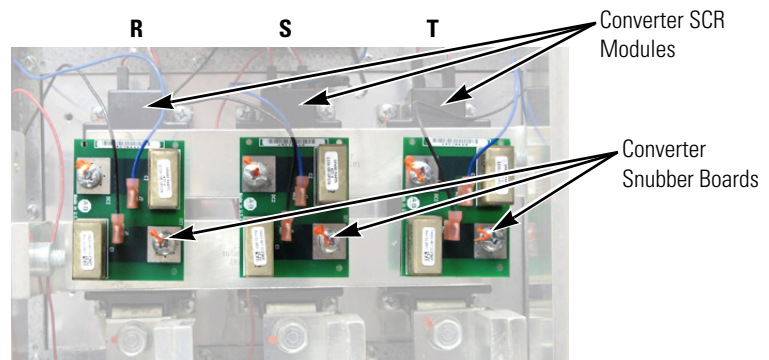

3. Remove all three converter snubber boards and set them aside.
  - a. Label and disconnect wires from the converter snubber board.
  - b. Remove the two screws that secure the board.
  - c. Remove the board and set aside.
4. Note the orientation of the converter busbars and remove the eight bolts that secure the busbars to the converter SCR modules and to the DC+ and DC- busbars. Set the converter busbars aside.

5. Disconnect the three AC busbars (R, S, T) at the top only.  
You do not need to remove the wires from the AC busbars.
6. Label and note the position of the converter SCR module leads. Remove the leads.  
Typically, the leads are marked as R, S, or T, and each is notched with the notch to the front of the converter SCR module.
7. Remove the four Phillips screws that hold each converter SCR to the heatsink and remove the converter SCR modules.

### Install Components

1. Use isopropyl alcohol to thoroughly clean the mounting surface of the heatsink and the mounting surface of each new converter SCR module.
2. Use a 3- or 4-inch paint roller or putty knife to apply a thin, even coating of the supplied thermal grease to the mounting surface of each new converter SCR module.

---

**IMPORTANT** In the next step, take care to not disturb any of the thermal grease on the converter SCR module.

---

3. Install each new converter SCR module with supplied screws and tighten using this torque sequence:

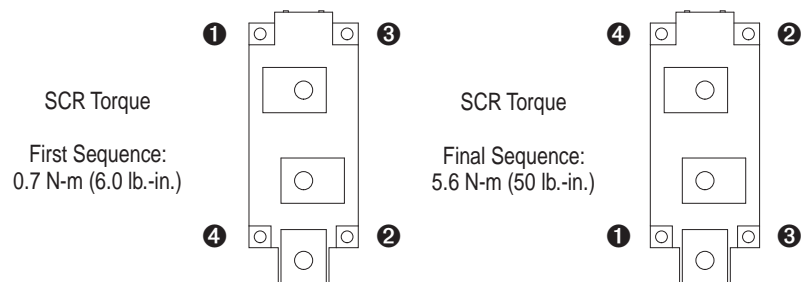

4. Replace the SCR module leads.  
Each set of leads is marked R, S, or T. The notch and red wire on each lead are positioned to the front.
5. Install the converter busbars per diagram in [step 2](#) and torque to 9.0 N•m (80 lb•in).
6. Install the snubber boards, oriented with the serial number at the top, and torque to 2.9 N•m (26 lb•in).
7. Replace the wires from the converter snubber resistors to the snubber boards.  
The black wire goes to J1. The blue wire goes to J2.
8. Reinstall AC busbars (R, S, T). Torque to 9.0 N•m (80 lb•in).

9. Reinstall the DC+ and DC- busbars and torque to 9.0 N•m (80 lb•in).
10. Install stacking panel as detailed on page [26](#).
11. Replace all safety shields and enclosure covers before applying power to the drive.

## Converter Snubber Resistors - AC Input Only

See Chapter 1 - Component Diagrams and Torque Specifications on page [15](#) to locate the component detailed in these instructions.

### Remove Components

Kit includes snubber board and resistor.

1. Read and follow the Safety Precautions on page [12](#) and Important Initial Steps on page [13](#).
2. Remove the stacking panel as detailed on page [26](#).

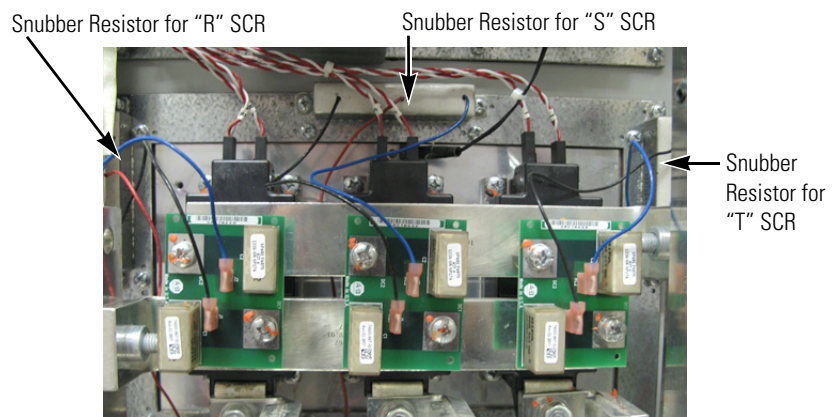

3. Verify the snubber resistor(s) with a volt ohm meter. The reading should be 8 ohms  $\pm$  10%.
  - If the reading is **not** within tolerance, perform the remainder of this procedure.
  - If the reading is within tolerance, do not perform the remainder of this procedure.
4. **For the R snubber resistor only:** Remove the transitional busbar assembly as detailed on page [28](#).
5. Label and disconnect the wires from snubber resistors that will be replaced.
6. Remove the resistor.

## Install Components

1. Use isopropyl alcohol to thoroughly clean the mounting surface of the heatsink and the mounting surface of the new snubber resistor.
2. Use a 3-inch paint roller or putty knife to apply a thin even coating of the supplied thermal grease to the mounting surface of the new snubber resistor and install. Torque screws to 2.9 N•m (26 lb•in).
3. Connect the wires.
4. **For the R snubber resistor only:** Install the transitional busbar assembly as detailed on page 28.
5. Install stacking panel as detailed on page 26.
6. Replace all safety shields and enclosure covers before applying power to the drive.

## Converter Snubber Board - AC Input Only

See Chapter 1 - Component Diagrams and Torque Specifications on page 15 to locate the component detailed in these instructions.

## Remove Components

1. Read and follow the Safety Precautions on page 12 and Important Initial Steps on page 13.
2. Remove the stacking panel as detailed on page 26.

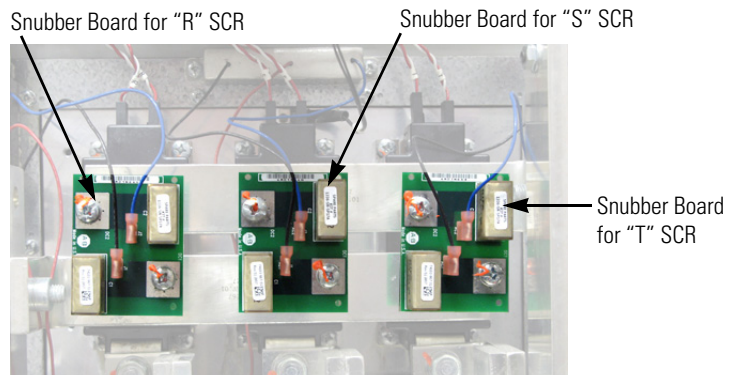

3. Label and disconnect wires from the converter snubber board to be replaced.
4. Remove the two screws that secure the board.
5. Remove the board.

## Install Components

1. Install the new snubber board. Torque screws to 2.9 N•m (26 lb•in).
2. Connect the wires.  
Black wire goes to J1. Blue wire goes to J2.
3. Install stacking panel as detailed on page [26](#).
4. Replace all safety shields and enclosure covers before applying power to the drive.

## Fan Transformer

See Chapter 1 - Component Diagrams and Torque Specifications on page [15](#) to locate the component detailed in these instructions.

## Remove Components

1. Read and follow the Safety Precautions on page [12](#) and Important Initial Steps on page [13](#).
2. Label and unplug or disconnect the five wires for the fan transformer.
3. Unscrew the four fan transformer mounting bracket screws.

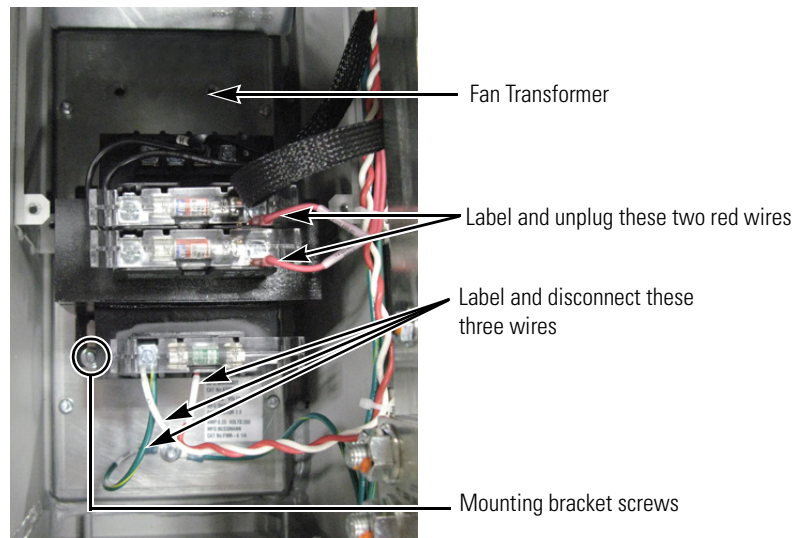

## Install Components

1. Install new fan transformer. Torque four screws to 5.6 N•m (50 lb•in).
2. Connect the wires for the fan transformer.
3. Replace all safety shields and enclosure covers before applying power to the drive.

## Heatsink Fan - Removal from Back of Drive

The heatsink fan is located on the back of the drive.

(For equipment clearance considerations, the fan can also be removed from the front of the drive. See [Heatsink Fan - Removal from Front of Drive on page 72.](#))

See Chapter 1 - Component Diagrams and Torque Specifications on page 15 to locate the component detailed in these instructions.



### Remove Components

1. Read and follow the Safety Precautions on page 12 and Important Initial Steps on page 13.
2. Verify that there is at least a 91 cm (3 ft) clearance in back of the drive for access to the heatsink fan.
3. From the front of the drive, disconnect the cables for both the fan and the fan capacitor.

Access the cables by gently pulling the wiring from behind the busbar mounting panel.

Front of drive

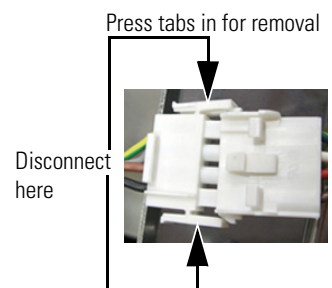
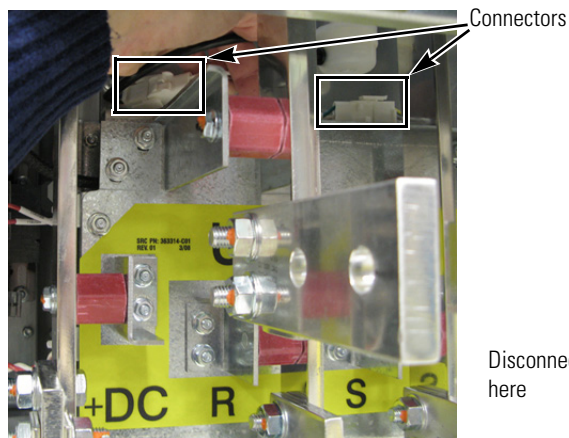

4. On the back of the drive, remove the eleven screws for the fan cover; see the figure on the next page for the screw locations.  
Do not remove the screws for the screen.
5. Use the handle to separate the fan assembly from the drive enclosure.  
Some force may be needed to separate the fan from the enclosure as the gasket may be tight or sticky.

6. Remove the fan.

**Fan Cover Screw Locations on Back of Drive**

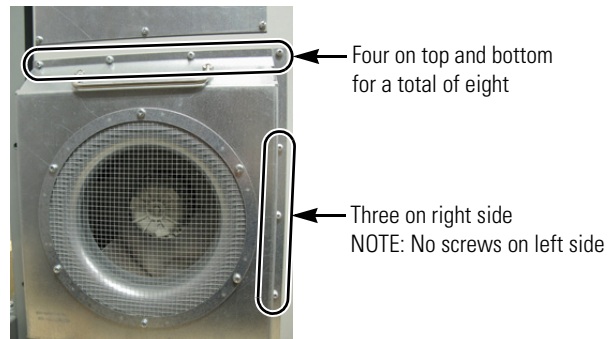

**Install Components**

1. Install the new gasket (if the old gasket was damaged).
2. Place the fan assembly into the chassis but not installed in final position. Leave space for accessing fan cables from the front of the drive.

Take care to not pinch wires.



3. From the front of the drive, connect the fan cables.

**TIP** The connectors, one set shown below, are designed so they go together only one way. The two end sections are flat on one side and each section has a ridge at the matching edge.

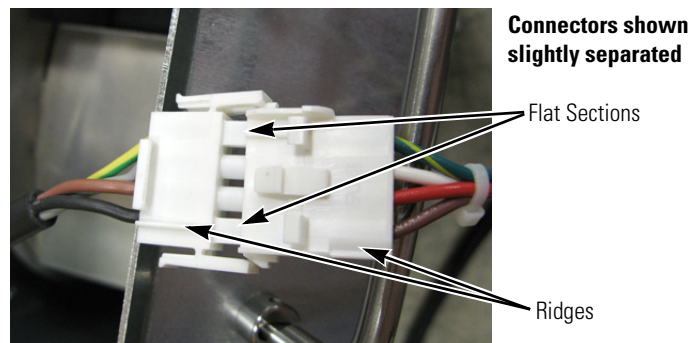

4. Place fan assembly in final position in the chassis.

5. On the back of the drive, install the eleven screws for the heatsink fan cover. Torque to 2.9 N•m (26 lb•in).

## Heatsink Fan - Removal from Front of Drive

The heatsink fan is located on the back of the drive. These instructions explain how to remove the fan from the front of the drive.

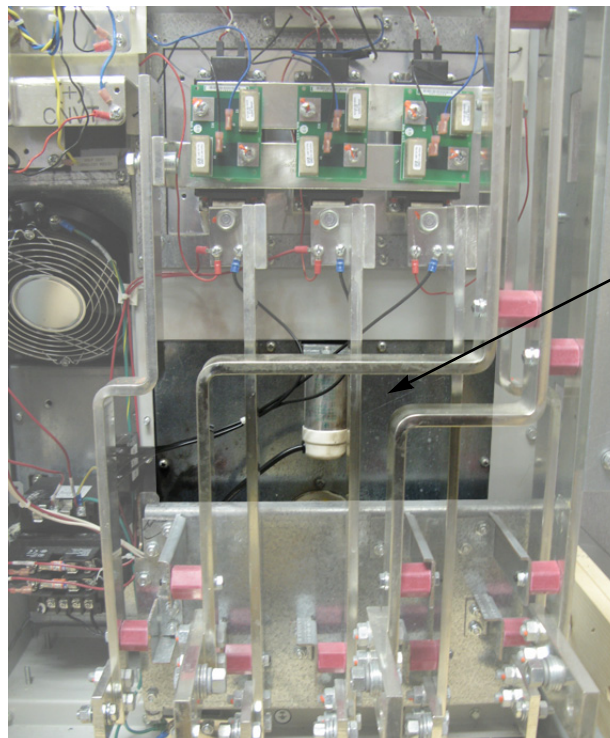

Heatsink Fan  
behind  
mounting  
plate

See Chapter 1 - Component Diagrams and Torque Specifications on page [15](#) to locate the component detailed in these instructions.

## Remove Components

1. Read and follow the Safety Precautions on page [12](#) and Important Initial Steps on page [13](#).
2. Disconnect all appropriate wiring to AC and DC busbars so you can remove entire set of busbars with the busbar mounting plate in a later step.
3. Remove the stacking panel as detailed on page [26](#).
4. Disconnect the DC+ and DC- busbars that connect to the converter busbars at the top of each bar.



Do not disconnect the U, V, or W busbars at the bottom.

**AC Drive Shown**

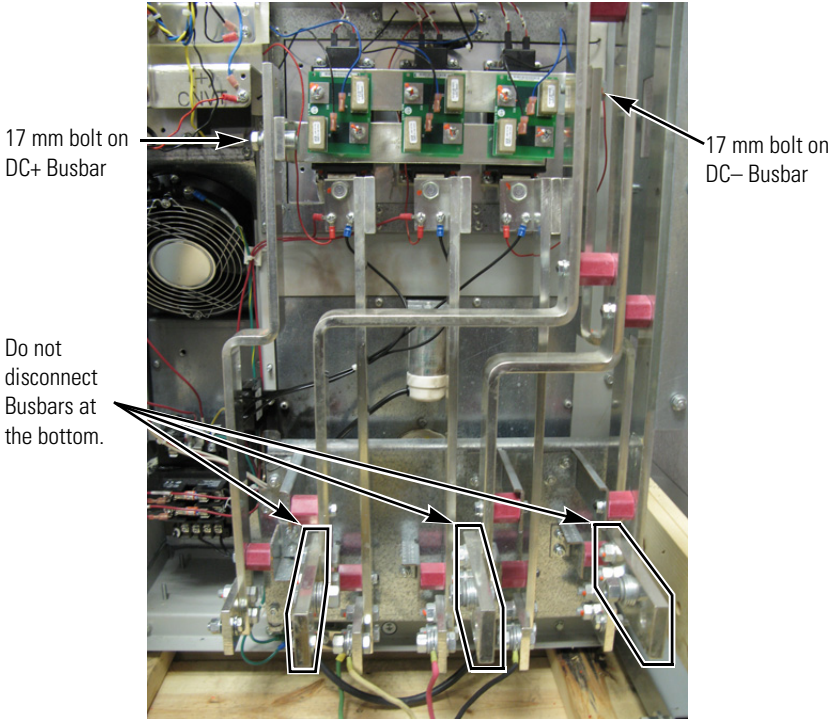

- 5. Disconnect all busbars where they connect to the converter SCR modules with 16 mm bolts. Disconnect wiring.

Do not disconnect the U, V, or W busbars at the bottom.

**AC Drive Shown**

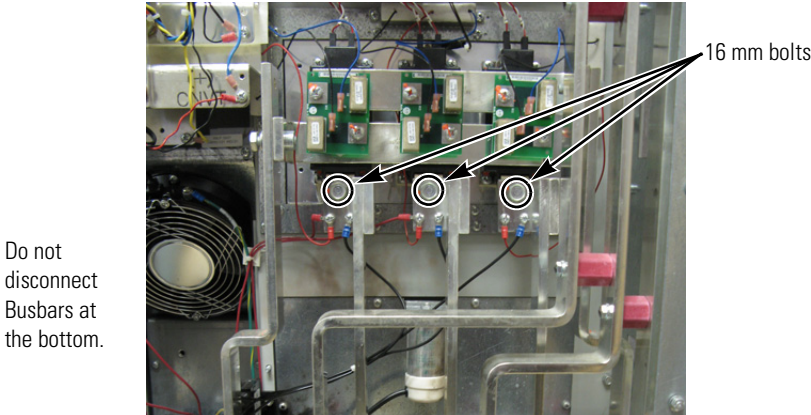

6. Disconnect the U, V, and W busbars at the top of each bar where they connect to the output busbars for the current transducers with two 17 mm bolts and one 11 mm nut.

Do not remove the busbars from the setscrew on the output busbars at this time.

Do not disconnect the U, V, or W busbars at the bottom.

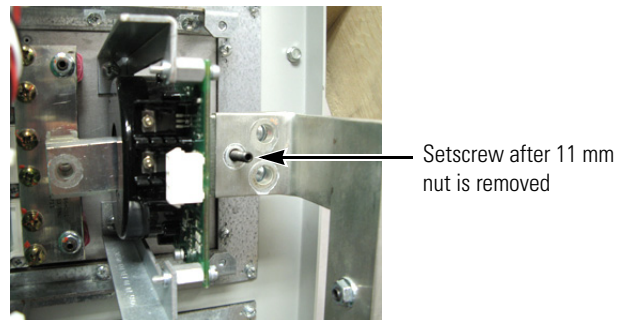
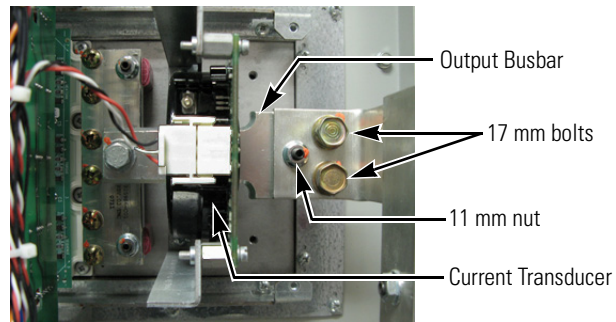

7. Remove the four 10 mm nuts for the busbars mounting plate.

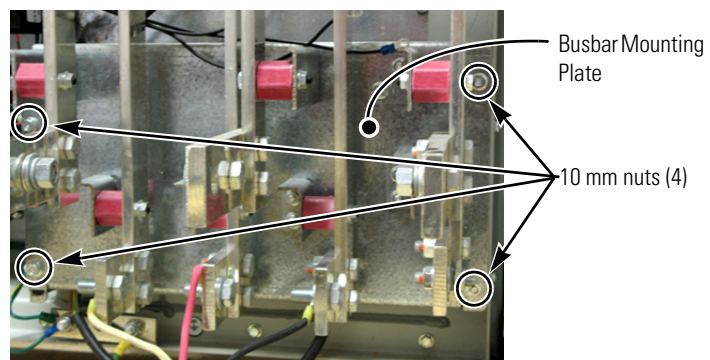

8. Remove the entire busbar and mounting plate assembly. Set aside.

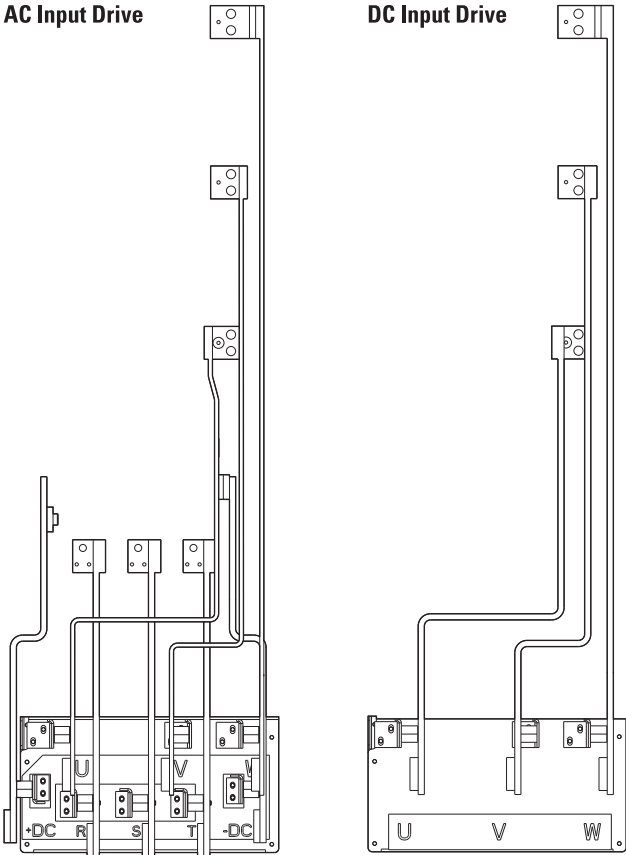

- 9. Unplug the fan cables.
- 10. For AC drives, remove the MOV surge suppressor as detailed on [page 80](#).
- 11. Remove the left busbar mounting plate bracket.
- 12. Remove the 12 exterior screws on the fan mounting plate.

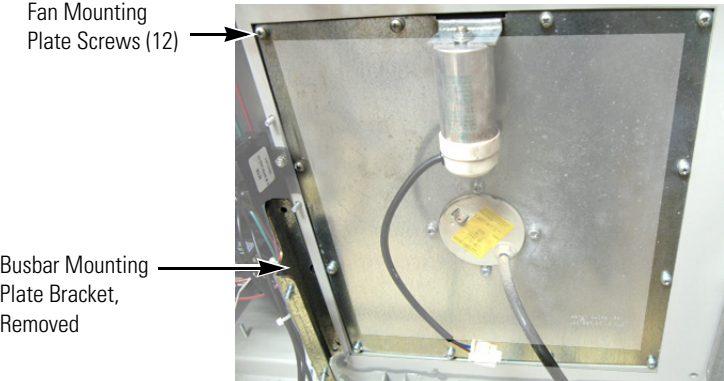

13. Carefully remove the mounting plate and fan through the front of the drive chassis; you may need to pry the mounting plate away from the gasket.

The fan housing remains mounted on the chassis.

## Install Components

1. Remove the new fan housing from the new fan and mounting plate.  
Discard the new fan housing.
2. Install the new gasket (if the old gasket was damaged) and mounting plate to the chassis. Torque the mounting screws to 2.9 N•m (26 lb•in).
3. Install the left busbar mounting plate bracket. Torque the mounting screws to 5.6 N•m (50 lb•in).
4. For AC drives, install the MOV surge suppressor as detailed on [page 80](#).
5. Connect the fan cables.
6. Install the busbar and mounting plate assembly:
  - a. Torque the four 10 mm nuts for the busbar mounting plate to 5.6 N•m (50 lb•in).
  - b. Torque the 11 mm mounting nut on the setscrew for each U, V, and W busbar at the current transducer output busbar to 5.6 N•m (50 lb•in).
  - c. Torque the two 17 mm mounting bolts for each U, V, and W busbar at the current transducer output busbar to 9 N•m (80 lb•in).
  - d. Torque the three 16 mm mounting bolts for the busbar connection to the converter SCR modules to 9 N•m (80 lb•in).
  - e. Torque the six wiring screws for the busbar connection to the converter SCR modules to 2.9 N•m (26 lb•in).
  - f. Torque the 17 mm mounting bolts for the DC+ and the DC- busbars (one each) that connect to the converter busbars to 23.5 N•m (208 lb•in).
7. Replace all safety shields and enclosure covers before applying power to the drive.

# Thermal Sensors

The thermal sensor system consists of:

- A sensor secured to the upper mounting bracket for the main control panel.
- A sensor secured to the heatsink above the SCR modules.
- A connector to J8 on each of the three gate interface boards.

See Chapter 1 - Component Diagrams and Torque Specifications on page 15 to locate the component detailed in these instructions.

**Thermal Sensor wiring for both drives**

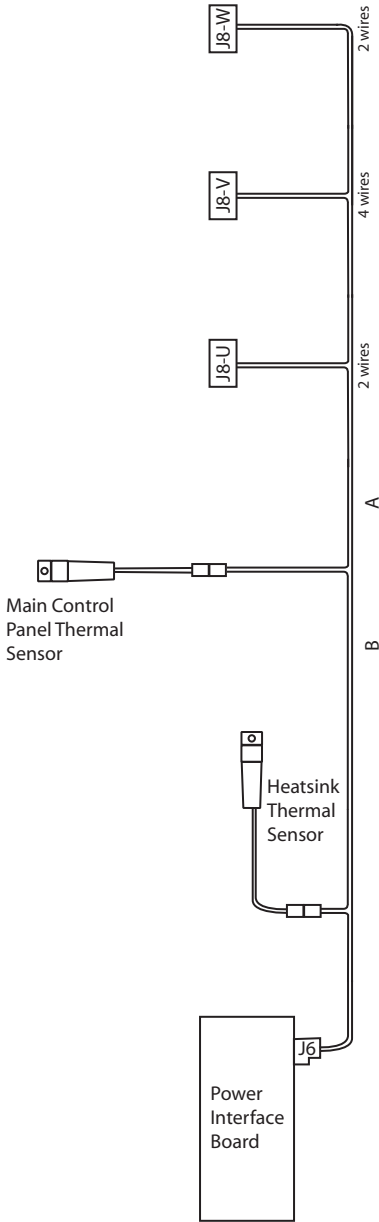

## Remove Components

1. Read and follow the Safety Precautions on page [12](#) and Important Initial Steps on page [13](#).
2. Cut the wire ties for the wiring harness along the gate interface boards.
3. Note wire routing and location of sensors.
4. For the main control panel thermal sensor, remove the screw and nut on the main control panel and disconnect the other end from the wiring harness.

---

**IMPORTANT** This screw and nut on the main control panel are small. Do not drop them.

---

5. For the Heatsink thermal sensor, remove the screw on the Heatsink above the SCR modules and unplug the other end from the wiring harness.

---

**IMPORTANT** This screw and nut on the heatsink are small. Do not drop them.

---

6. Label the wires and unplug the J8 connectors on each of the three gate interface boards, and unplug the other end of this wiring harness at the J6 connector on the power interface board.

## Install Components

1. Use isopropyl alcohol to thoroughly clean the mounting surface of the control panel and heatsink, and the mounting surface of the thermal sensors.
2. Apply a thin layer of supplied thermal grease to the metal side of the new thermal sensors.
3. Install the thermal sensors with the screw and star washer. Hand tighten.
4. For the three gate interface boards, carefully route wires and connect to J8 on each gate interface board.  
  
Be sure that the J8 connectors go to the correct IGBT.
5. Connect the other end of this wiring harness at the J6 connector on the power interface board.
6. Secure the wire harnesses with plastic ties.
7. Replace all safety shields and enclosure covers before applying power to the drive.

## DC Link Choke - AC Input Only

See Chapter 1 - Component Diagrams and Torque Specifications on page [15](#) to locate the component detailed in these instructions.

### Remove Components

1. Read and follow the Safety Precautions on page [12](#) and Important Initial Steps on page [13](#).
2. Label and disconnect DC choke connectors.
3. Remove the four screws for the DC link choke mounting brackets.
4. Remove the DC link choke.



+DC (Back/L2 Connector)      +DC (Back/L1 Connector)  
-DC (Front/L3 Connector)    -DC (Front/L4 Connector)  
DC Choke Connectors

### Install Components

1. Install the new DC link choke mounting brackets to the drive. Torque the four mounting screws to 9.0 N•m (80 lb•in).
2. Install the choke connectors. Torque the four choke connector screws to 9.0 N•m (80 lb•in).
3. Replace all safety shields and enclosure covers before applying power to the drive.

## MOV Surge Suppressor - AC Input Only

See Chapter 1 - Component Diagrams and Torque Specifications on page 15 to locate the component detailed in these instructions.

### Remove Components

1. Read and follow the Safety Precautions on page 12 and Important Initial Steps on page 13.
2. Remove the stacking panel as detailed on page 26.

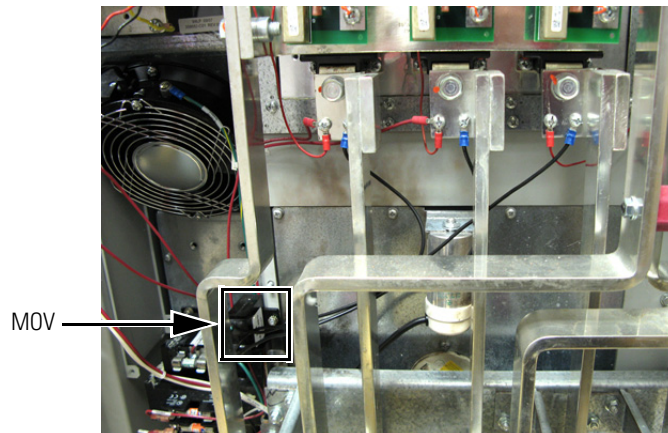

3. Note wire placement and connections. Disconnect the MOV ground wire and the R, S, and T wires to the AC busbars.
4. Remove the MOV mounting nut.
5. Remove the MOV assembly.

### Install Components

1. Install the new MOV assembly. Torque the MOV mounting nut to 2.9 N•m (26 lb•in).
2. Connect all wires and connectors for the MOV.
3. Torque the R, S, and T Phase power terminal block screws to 2.9 N•m (26 lb•in).
4. Torque the ground wire nut to 9.0 N•m (80 lb•in).
5. Install the stacking panel as detailed on page 26.
6. Replace all safety shields and enclosure covers before applying power to the drive.



## Precharge SCR Module and Diode - DC Input Only

See Chapter 1 - Component Diagrams and Torque Specifications on page [15](#) to locate the component detailed in these instructions.

### Remove Components

1. Read and follow the Safety Precautions on page [12](#) and Important Initial Steps on page [13](#).
2. Remove the stacking panel as detailed on page [26](#).

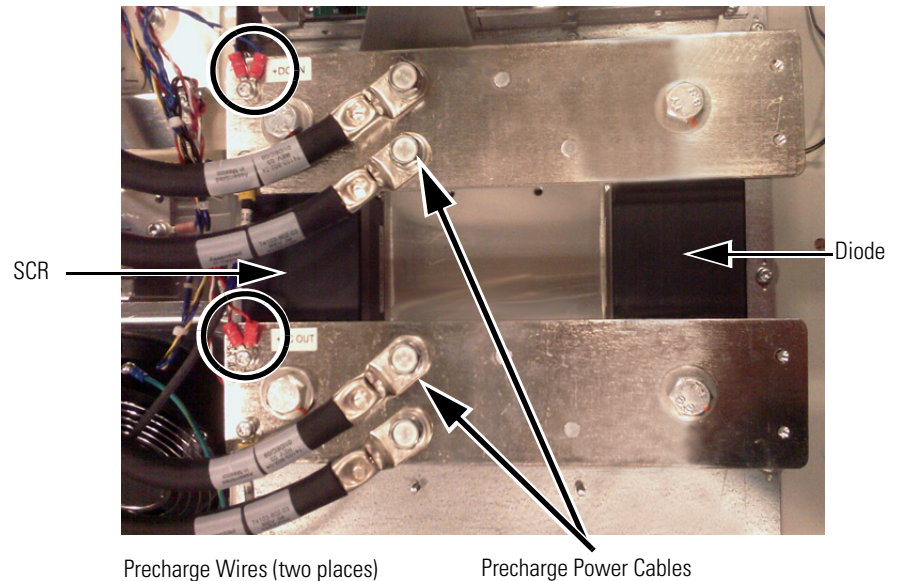

3. Label and remove all precharge power cables and precharge wires from both precharge busbars (DC+ IN and DC+ OUT.)
4. Remove both precharge busbars and carefully set aside.
5. For the precharge SCR module, remove its connector wire.
6. Remove the SCR module and diode.

### Install Components

1. Use isopropyl alcohol to thoroughly clean the mounting surface of the heatsink and the mounting surface of the new SCR module and diode.
2. Use a 3- or 4-inch paint roller or putty knife to apply a thin, even coating of the supplied thermal grease to the mounting surface of each SCR module and diode.



**WARNING:** In the next step, be sure to properly install the modules as shown. If you install the SCR incorrectly, it will not work. If you install the diode incorrectly, then the drive and the bus capacitors may not operate properly and may prematurely fail.

- The SCR (on the left) has a plug **with** prongs located at the bottom.
- The diode (on the right) has a plug **without** prongs located at the top.

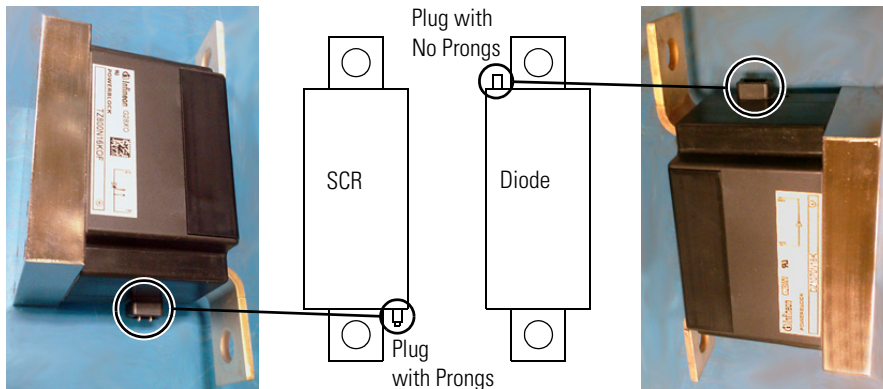

**IMPORTANT** In the next step, take care to not disturb any of the thermal grease on the SCR module.

3. Install the SCR module or diode with supplied screws and torque using the sequences and specifications shown in the diagram below.

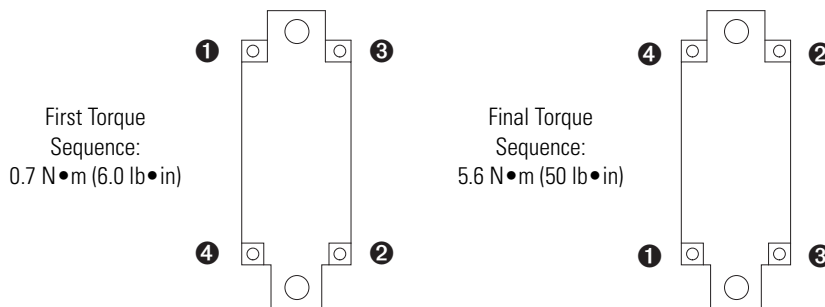

4. Install the precharge busbars. Torque to 5.6 N•m (50 lb•in).
5. Install the precharge wires. Torque to 2.9 N•m (26 lb•in).
6. Install the precharge cables. Torque the screws to 12.2 N•m (108 lb•in).
7. Install the stacking panel as detailed on page [26](#).
8. Replace all safety shields and enclosure covers before applying power to the drive.

## History of Changes

This appendix summarizes the revisions to this manual. Reference this appendix if you need information to determine what changes have been made across multiple revisions. This can be useful if you are deciding to upgrade your hardware based on information added with previous revisions of this manual.

### 20B-IN024C-EN-P, June 2012

Topic
Added additional resources table.
Updated the torque specifications table.
Updated torques and steps for these install components procedures:
Main control panel
Stacking panel
Transitional busbar assembly
Main control board
T-comm board
Power interface board
Switch mode power supply board
Precharge board
Bus capacitor
Capacitor bank fan
Balancing resistor
Balancing resistor
Gate interface board
Current transducer
Converter power module (SCR) – AC input only
Converter snubber resistors – AC input only
Converter snubber board – AC input only
Fan transformer
Heatsink fan - removal from back of drive
Heatsink fan - removal from front of drive
Thermal sensor

---

**Topic**

---

DC link choke – AC input only

---

MOV surge suppressor – AC input only

---

Precharge SCR module and diode – DC input only

---



## Rockwell Automation Support

Rockwell Automation provides technical information on the Web to assist you in using its products.

At <http://www.rockwellautomation.com/support> you can find technical and application notes, sample code, and links to software service packs. You can also visit our Support Center at <https://rockwellautomation.custhelp.com/> for software updates, support chats and forums, technical information, FAQs, and to sign up for product notification updates.

In addition, we offer multiple support programs for installation, configuration, and troubleshooting. For more information, contact your local distributor or Rockwell Automation representative, or visit <http://www.rockwellautomation.com/services/online-phone>.

## Installation Assistance

If you experience a problem within the first 24 hours of installation, review the information that is contained in this manual. You can contact Customer Support for initial help in getting your product up and running.

United States or Canada	1.440.646.3434
Outside United States or Canada	Use the <a href="#">Worldwide Locator</a> at <a href="http://www.rockwellautomation.com/rockwellautomation/support/overview.page">http://www.rockwellautomation.com/rockwellautomation/support/overview.page</a> , or contact your local Rockwell Automation representative.

## New Product Satisfaction Return

Rockwell Automation tests all of its products to help ensure that they are fully operational when shipped from the manufacturing facility. However, if your product is not functioning and needs to be returned, follow these procedures.

United States	Contact your distributor. You must provide a Customer Support case number (call the phone number above to obtain one) to your distributor to complete the return process.
Outside United States	Please contact your local Rockwell Automation representative for the return procedure.

## Documentation Feedback

Your comments will help us serve your documentation needs better. If you have any suggestions on how to improve this document, complete this form, publication [RA-DU002](#), available at <http://www.rockwellautomation.com/literature/>.

Rockwell Automation maintains current product environmental information on its website at <http://www.rockwellautomation.com/rockwellautomation/about-us/sustainability-ethics/product-environmental-compliance.page>.

Rockwell Otomasyon Ticaret A.Ş., Kar Plaza İş Merkezi E Blok Kat:6 34752 İçerenköy, İstanbul, Tel: +90 (216) 5698400

**[www.rockwellautomation.com](http://www.rockwellautomation.com)**

### Power, Control and Information Solutions Headquarters

Americas: Rockwell Automation, 1201 South Second Street, Milwaukee, WI 53204-2496 USA, Tel: (1) 414.382.2000, Fax: (1) 414.382.4444  
Europe/Middle East/Africa: Rockwell Automation NV, Pegasus Park, De Kleetlaan 12a, 1831 Diegem, Belgium, Tel: (32) 2 663 0600, Fax: (32) 2 663 0640  
Asia Pacific: Rockwell Automation, Level 14, Core F, Cyberport 3, 100 Cyberport Road, Hong Kong, Tel: (852) 2887 4788, Fax: (852) 2508 1846

Publication 20B-IN024D-EN-P - October 2015

Supersedes Publication 20B-IN024C-EN-P - June 2012

Copyright © 2015 Rockwell Automation, Inc. All rights reserved. Printed in the U.S.A.