

# Floor Mounting Column and Cantilever User Manual

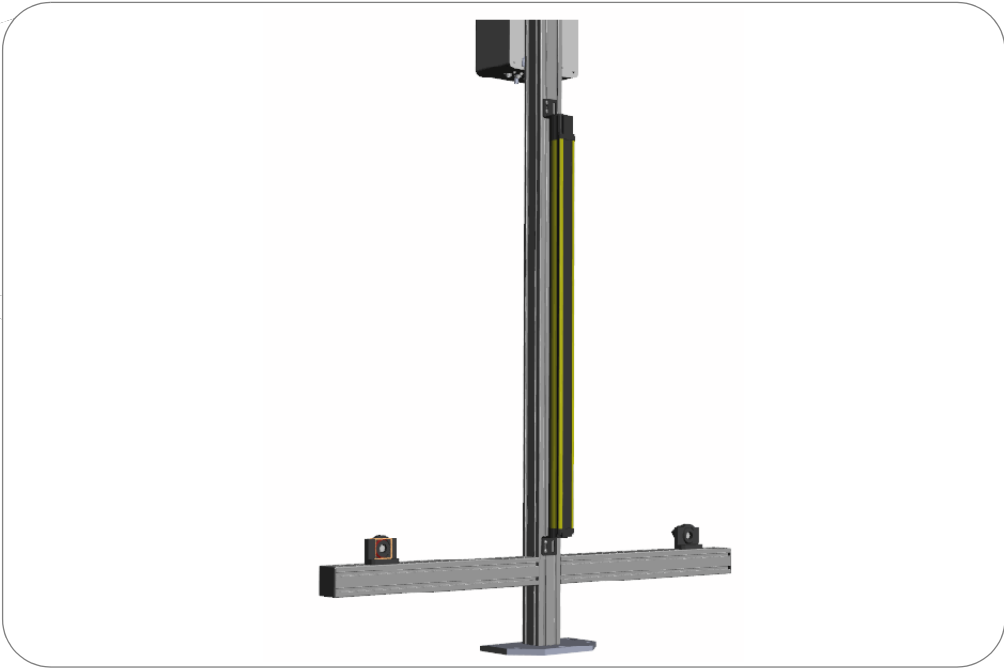

## Important User Information





Because of the variety of uses for the products described in this publication, those responsible for the application and use of this control equipment must satisfy themselves that all necessary steps have been taken to assure that each application and use meets all performance and safety requirements, including any applicable laws, regulations, codes and standards.

The illustrations, charts, sample programs and layout examples shown in the guide are intended solely for purposes of example. Since there are many variables and requirements associated with any particular installation, Rockwell Automation does not assume responsibility or liability (to include intellectual property liability) for actual use based upon the examples shown in this publication.

Rockwell Automation publication SGI-1.1, Safety Guidelines for the Application, Installation and Maintenance of Solid-State Control (available from your local Rockwell Automation sales office), describes some important differences between solid-state equipment and electromechanical devices that should be taken into consideration when applying products such as those described in this publication.

Reproduction of the contents of this copyrighted publication, in whole or part, without written permission of Rockwell Automation, is prohibited.

Throughout this manual we use notes to make you aware of safety considerations:

<b>WARNING</b> 	Identifies information about practices or circumstances that can cause an explosion in a hazardous environment, which may lead to personal injury or death, property damage, or economic loss.
<b>IMPORTANT</b>	Identifies information that is critical for successful application and understanding of the product.
<b>ATTENTION</b> 	Identifies information about practices or circumstances that can lead to personal injury or death, property damage, or economic loss. Attentions help you identify a hazard, avoid a hazard, and recognize the consequences.
<b>SHOCK HAZARD</b> 	Labels may be on or inside the equipment (for example, drive or motor) to alert people that dangerous voltage may be present.
<b>BURN HAZARD</b> 	Labels may be on or inside the equipment (for example, drive or motor) to alert people that surfaces may reach dangerous temperatures.

It is recommended that you save this user manual for future use.



## Introduction

The Allen-Bradley Guardmaster aluminum mounting stand is offered in a two meter length and is supplied with a floor mounting plate and the hardware necessary to mount the floor plate to the aluminum extrusion as well as leveling hardware for the floor plate. The two meter aluminum extrusion has a cross section of 60 x 60 mm (2.36 x 2.36 in.).

The two meter mounting stand is designed for mounting safety light curtains, corner mirrors, and the 445L muting box. The two meter mounting stand can also be used for entry and exit end muting. A 500 mm long 60 x 60 mm aluminum section is offered with mounting hardware and a black end-cap cover. One section attached to the two meter mounting stand allows an “L” type, two-sensor muting solution, two 500 mm sections allow for two- or four-sensor “T” type muting. The slots in the extrusion allow easy assembly and positioning of muting sensors and reflectors.

### IMPORTANT

If an “L” or “T” type configuration is planned, it is best to assemble the 500 mm sections to the two meter post prior to installing the floor plate.

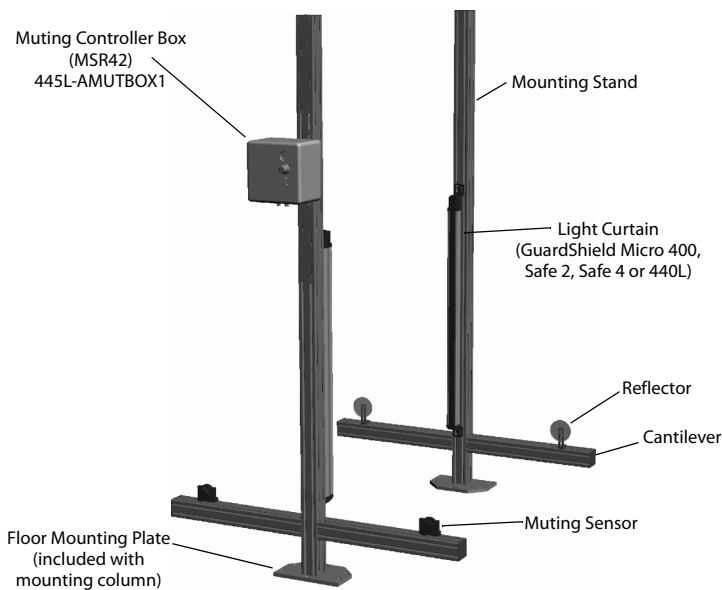

Micro 400 example



Safe 4 example

Figure 1: Mounting stand used for safety light curtain in a muting system

## 445L-AMSTD2M Floor Mounting Stand

### Step 1: Supplied parts

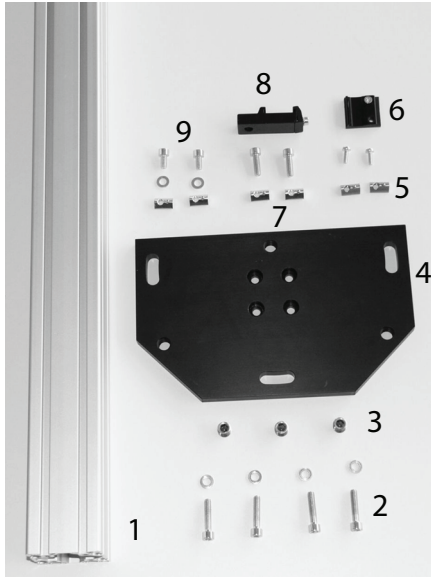

Pos	Qty	Description
1	1 pc.	Profile 60 x 60 x 2000 mm (2.4 x 2.4 x 78.7 in.)
2		<u>Floor plate to extrusion mounting hardware</u>
	4 pcs.	Zinc hexagon socket head cap screws DIN 912 M6 x 25 mm (0.98 in.)
	6 pcs.	Zinc washer (flat) M6 x 12 mm (0.47 in.)
3	3 pcs.	Zinc set screw DIN 913 M12 x 12 mm (0.47 in.)
4	1 pc.	Aluminum, black anodized floor mounting plate
5		<u>Micro 400 bracket hardware (bracket not included)</u>
	2 pcs.	Zinc-plated T-slot nut 6 steel M4
	2 pcs.	Hexagon socket head cap screw DIN 912 M4 x 14 mm (0.55 in.)
6		<u>Brackets</u>
		445L-AF6145 Micro 400 flat bracket (not included)
7		<u>Safe 4 bracket 445L-AF6140 hardware (bracket not included)</u>
	2 pcs.	Zinc-plated T-slot nut 6 steel M6
	2 pcs.	Hexagon socket head cap screw DIN 912 M6 x 20 mm (0.79 in.)
8		<u>Brackets</u>
		445L-AF6140 Safe 2/4 bracket (not included)
9		<u>Muting box hardware (muting box not included)</u>
	2 pcs.	Zinc-plated T-slot nut 6 steel M5
	2 pcs.	Zinc washer (flat) M5 x 10 mm (0.39 in.)
	2 pcs.	Hexagon socket head cap screw DIN 912 M5 x 12 mm (0.47 in.)
Not shown:		
	4 pcs.	Cover profiles for hiding cables (aluminum, 300 mm (11.8 in.))
	1 pcs.	Profile top cap 60 x 60 mm (2.4 x 2.4 in.)

### Step 2: Assembling floor plate to post



Position the floor plate to the bottom of the two meter post with the recessed holes opposite the post. Premount the screws with the washer in the holes of the floor plate.

<b>IMPORTANT</b>	For use as a muting system, assemble cantilevered arms prior to installing the floor mounting plate.
------------------	--

### Step 3: Leveling hardware

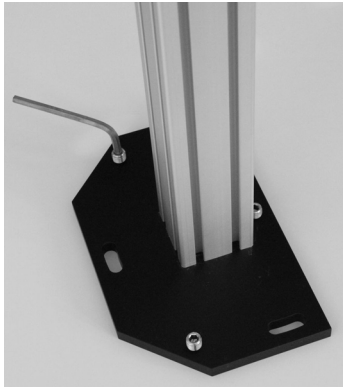

Three hexagon socket head cap screws are supplied to level the floor plate. If necessary, premount these screws before attaching the floor plate to the aluminum post.

### Step 4: Install profile covers

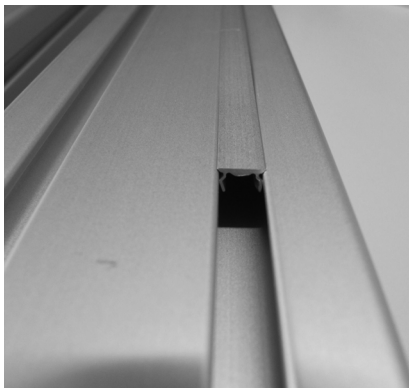

Four 300 mm profile covers are supplied with each two meter post to hide the cables. Install these after the cables are assembled and connected. Use a rubber mallet to secure these profile covers to the two meter post.

### Step 5: Leveling the two meter post kit

When the floor plate is positioned and loosely secured to the floor, adjust each leveling screw to assure the two meter post is attached to the floor. Then tighten the floor plate to the floor.

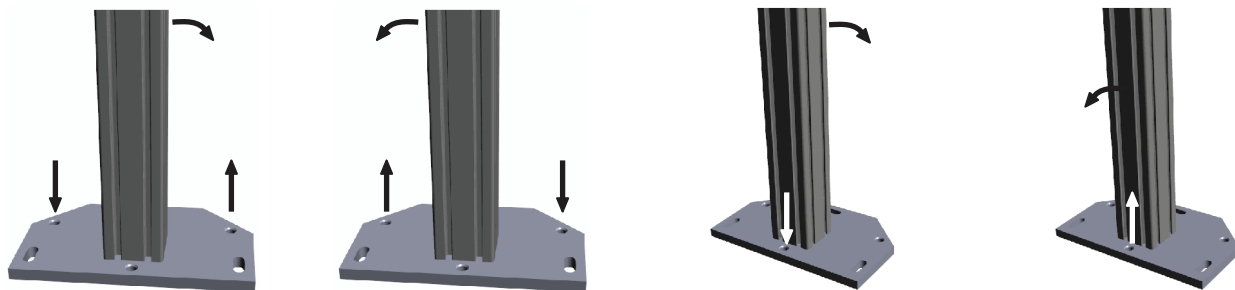

## 445L-AMSTDMUT Cantilever—Assembly Steps

### Step 1: Supplied parts

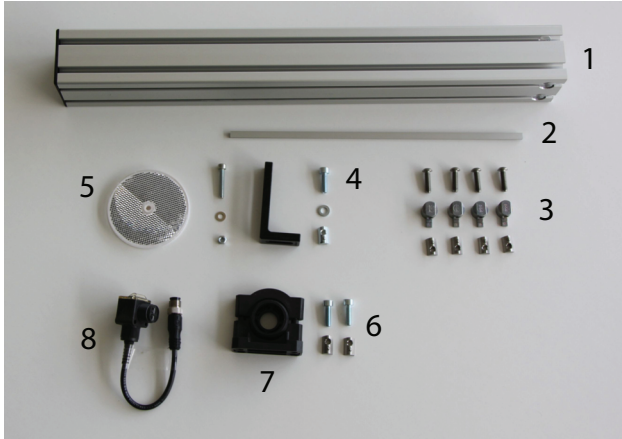

Pos	Qty	Description
1	1 pc.	Aluminum profile 60 x 60 x 500 mm (2.4 x 2.4 x 19.7 in.)
	1 pc.	Black end cap 60 x 60
2	1 pc.	Aluminum cover profiles for hiding cables (300 mm (11.8 in.))
3		<u>To attach cantilever post to the floor stand post</u>
	4 pcs.	Stainless steel universal fastening set #6 (item no. 0044174)
4	1 pc.	<u>Mounting kit for reflector (reflector not supplied)</u>
	1 pc.	bracket 80 x 40 x 20 Zn (Item No. 0047463)
		<u>Bracket mounting hardware:</u>
	1 pc.	washer (flat) M6 x 12 mm (0.47 in.) (zinc)
	1 pc.	hexagon socket head cap screw DIN 912 M6 x 16 mm (0.63 in.)
	1 pc.	T-slot nut 6 steel M6, zinc plated
		<u>Reflector mounting hardware</u>
	1 pc.	hexagon socket head cap screw DIN 912 M5 x 30 mm (1.18 in.)
	1 pc.	washer (flat) M5 x 10 mm (0.39 in.) (zinc)
	1 pc.	hexagon nut DIN 934 M5 (zinc)
6		<u>RightSight bracket 60-2649 mounting hardware</u>
	2 pcs.	Hexagon socket head cap screw DIN 912 M6 x 14 mm (0.55 in.)
	2 pcs.	T-slot nut 6 steel M6, zinc plated

### Optional parts for muting—not supplied

- 8 RightSight retroreflective sensor 42EF-P2MPB-Y4
- 7 RightSight swivel/tilt bracket 60-2649
- 4-pin straight DC micro QD patchcord 889D-F4ABPM-X (X is length in meters) (not shown)
- 5 Large reflector 92-39 (76 mm (3 in.) diameter) or small reflector 92-47 (32 mm (1.25 in.) diameter)

### Step 2: Assemble 500 mm cantilever post



Slide the four universal fastening sets in each slot on the left or the right side of floor mounting stand.

Place the lower universal fastening sets at the desired height. Make sure that the bezels of the lower universal fastening sets are on the upside.

Place the upper universal fastening sets about 100 mm higher than the lower ones. Make sure that the upper bezels of the universal fastening sets are on the underside.



### Step 3: Securing 500 mm cantilever to post



Hold the cantilever profile between the universal fastening sets. Using a #4 hex tool tighten the hex head screws.

### Step 4: Installing muting sensors and reflectors

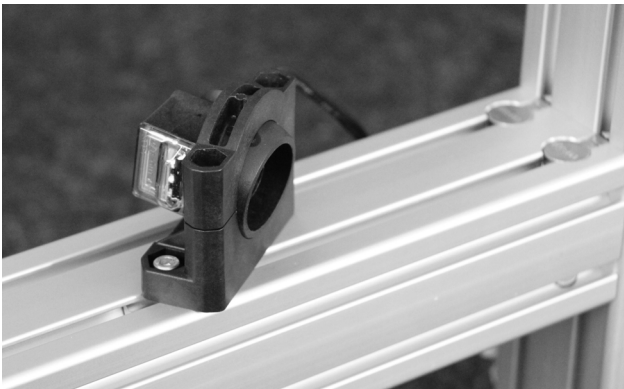

Mount the muting sensor to the bracket. Mount the muting sensor and the bracket to the slot in the extrusion using the supplied hardware.

### Step 5: Installing reflector



Mount the reflector to the supplied bracket. Mount the bracket to the extrusion slot using the supplied hardware. Position the reflector and tighten bracket hardware.

### Step 6: Mount cover profiles

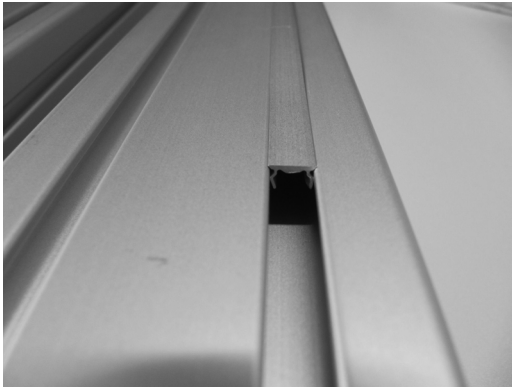

Run cables in the slots once the system is complete. Finish the assembly by positioning the profile covers. Using a rubber mallet or a block of material that will not damage the material, lightly tap the cover profiles in place.

### Dimensions [mm (in.)]

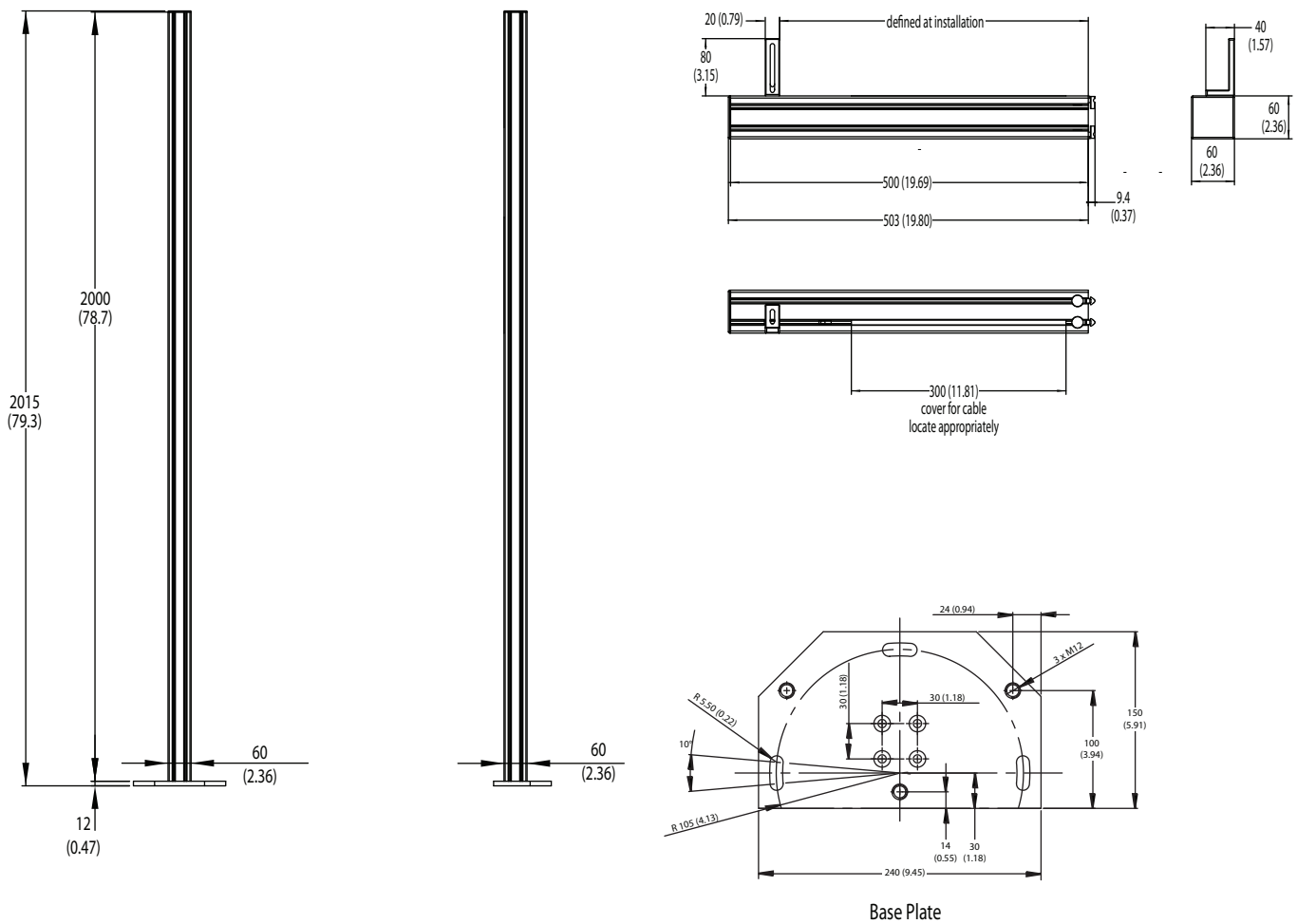









GuardShield is a trademark of Rockwell Automation, Inc.

**[www.rockwellautomation.com](http://www.rockwellautomation.com)**

---

**Power, Control and Information Solutions Headquarters**

Americas: Rockwell Automation, 1201 South Second Street, Milwaukee, WI 53204 USA, Tel: (1) 414.382.2000, Fax: (1) 414.382.4444

Europe/Middle East/Africa: Rockwell Automation, Vorstlaan/Boulevard du Souverain 36, 1170 Brussels, Belgium, Tel: (32) 2 663 0600, Fax (32) 2 663 0640

Asia Pacific: Rockwell Automation, Level 14, Core F, Cyberport 3, 100 Cyberport Road, Hong Kong, Tel: (852) 2887 4788, Fax: (852) 2508 1846